

1

2

3



IBEX

IDAHO'S BEST EXTERIORS

A

A

PROPERTY OF IBEX
 NOT FOR REPRODUCTION WITHOUT PRIOR
 WRITTEN CONSENT OF IBEX METAL, LLC

**PRODUCT
 CATALOG**

METAL ROOFING
 SIDING & TRIM

**PANEL & TRIM
 REFERENCE**



Metal Roofing, Siding, and Trim

P: 208-565-3002
www.ibexmetal.com
info@ibexmetal.com

280 Great Northern Road
 Bonners Ferry, ID 83805

PRODUCT CATALOG

COVER

INDEX

i INDEX

PANELS

GR8 TUFF-RIB (GR8)
 GR818 TUFF-RIB 18" (GR8)
 GR824 TUFF-RIB 24" (GR8)
 1SL SNAPLOCK PANEL (16")
 15SL SNAPLOCK PANEL (14 3/4")
 15SS 1.5" STANDING SEAM (16")
 2SS STANDING SEAM PANEL STRON...
 2SS STANDING SEAM PANEL (14 5/16")
 BB BOARD & BATTEN (SIDING)

SOFFI... SOFFIT PANEL

TRIM

01 RIDGE
 01F RIDGE CAP - FOLDED
 01R RIDGE CAP - RIBBED
 01B RIDGE CAP - ARCHITECTURAL
 01C RIDGE CAP (OVERSIZE 10/12)
 01H RIDGE CAP - HERITAGE
 02 VALLEY
 02B JUMBO VALLEY
 02C CLEATED VALLEY
 02D JUMBO CLEATED VALLEY
 03 PROW FLASHING
 04 PITCH BREAK (TRANSITION)
 04B JUMBO PITCH BREAK
 04C ENDWALL
 04D JUMBO ENDWALL
 04E SIDEWALL
 04F JUMBO SIDEWALL
 04J STEPPED ENDWALL
 05 J-CHANNEL
 05B MINI J-CHANNEL
 05C FULL WRAP J-CHANNEL

05D REVERSE OVERSIZE J-CHANNEL
 05E J-CHANNEL (1" RIB)
 05F FULL WRAP J-CHANNEL (1" RIB)
 05G FULL WRAP MINI J-CHANNEL
 05J J-CHANNEL (2" FACE)
 06 MINI GABLE
 06B MINI MINI GABLE
 06C OVERSIZE GABLE
 06D STANDING SEAM GABLE (1.5" RIB)
 06E STANDING SEAM GABLE (1" RIB)
 07 MINI EAVE
 07B STANDING SEAM EAVE
 07C JUMBO STANDING SEAM EAVE
 08 INSIDE CORNER
 08B ARCH'L INSIDE CORNER
 08C TRIM FIRST INSIDE CORNER
 08D TRIM FIRST I/C (1" RIB)
 09 DRIP EDGE
 09B DRIP EDGE B
 09C DRIP EDGE C
 09D 2X2 DRIP EDGE
 10 POST TRIM
 10B POST TRIM (NO HEM)
 10C PLAIN FASCIA
 10R RIBBED FASCIA
 10D INSIDE ANGLE
 10E BIG RIB FASCIA
 11 RAT GUARD
 11B FAT RAT
 11C RAT GUARD (1" RIB)
 12 SNOW GUARD
 12B MINI SNOW GUARD
 13 L BASE
 13B L BASE (1" RIB)
 13C FULL WRAP L BASE
 14 OUTSIDE CORNER
 14F FOLDED OUTSIDE CORNER
 14R OUTSIDE CORNER (RIBBED)

14B OVERSIZE OUTSIDE CORNER
 14C MINI OUTSIDE CORNER
 14D ARCH'L OUTSIDE CORNER
 14E TRIM FIRST OUTSIDE CORNER
 14G TRIM FIRST O/C (1" RIB)
 14H OUTSIDE CORNER (HERITAGE)
 15 WALL LITE
 15B FULL WRAP WALL LITE
 15C WALL LITE (1" RIB)
 15D FULL WRAP WALL LITE (1" RIB)
 16 FJ TRIM
 16B MINI FJ TRIM
 16C FULL WRAP FJ TRIM
 16D FULL WRAP MINI FJ TRIM
 16E MINI FJ TRIM (1" RIB)
 16F FULL WRAP MINI FJ TRIM (1" RIB)
 16G FJ TRIM (2" FACE)
 16J MINI FJ TRIM (2" FACE)
 17 POST FJ TRIM
 17B POST FJ TRIM (1" RIB)
 17C HEADER TRIM
 17D HEADER TRIM (1" RIB)
 18 ROOF TO WALL
 19 B & B CLEAT
 19B OPEN HEM CLEAT
 20 Z TRIM (1.5" RIB)
 20B Z TRIM B (1" RIB)
 20C Z TRIM C (HERITAGE)
 20D Z TRIM D (2" RIB)
 21 TRIM FIRST RAKE (1" RIB)
 21B TRIM FIRST RAKE (1.5" RIB)
 22 ARCH'L RAKE/GABLE
 22C MINI ARCH'L RAKE/GABLE
 22D 3 PC ARCH'L RAKE/GABLE
 23 CONCEALED EAVE TRIM
 24 TRACK COVER
 25 UNIVERSAL FLASHING
 26 OFFSET CLEAT

26B CLEAT
 26C GABLE CLEAT
 27 ARCH'L POST/DOOR TRIM
 28 ARCHITECTURAL TRIM
 29 BOARD BAND
 29B BOARD BAND (1" RIB)
 304 4X4 POST WRAP
 305 (3) 2X6 STUD POST WRAP
 306 6X6 POST WRAP
 31 PEAK FLASHING
 31B ARCHITECTURAL PEAK FLASHING
 31C JUMBO ARCH'L PEAK FLASHING
 31D 3 PC ARCH'L PEAK FLASHING
 32 REGLET FLASHING
 33 SNOW DIVERTER
 34 SOFFIT TRIM
 34B MINI SOFFIT TRIM
 34C MINI SOFFIT TRIM (1" RIB)
 35 H CHANNEL
 35B H CHANNEL (1" RIB)
 50 TRIM FIRST ENDWALL
 50A TRIM FIRST ENDWALL (1" RIB)
 50B STANDING SEAM ENDWALL
 50C STANDING SEAM SIDEWALL
 50D STANDING SEAM PITCH BREAK
 50E CLEATED PITCH BREAK
 60 PINE HILL EAVE/GAMBREL
 61 PINE HILL OUTSIDE CORNER
 62 COLOR GUARD
 63 BEACHY BUILDING EAVE
 64 ADEX ROOFING DRIP EDGE
 65 ADEX ROOFING GABLE
 66 ADEX ROOFING RIDGE
 67 ADEX Z TRIM
 79 INTEGRITY POLE BUILDING J
 81 SOFFIT RIDGE
 82 DOOR JAMB

PRODUCT CATALOGMETAL ROOFING
SIDING & TRIM**PRODUCT CATALOG
INDEX**

Metal Roofing, Siding, and Trim

P: 208-565-3002
www.ibexmetal.com
info@ibexmetal.com280 Great Northern Road
Bonners Ferry, ID 83805

1

2

3

FRACTIONS ROUNDED TO NEAREST 1/16"
 REVISED: 12/12/23

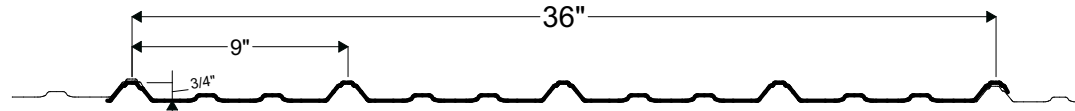

- Available with DRIPSTOP®
- No MIN or MAX length requirements
- 36" Coverage
- 3/4" Rib height
- Vented panel available
- 3:12 MIN recommended roof pitch
- 1:12 MIN pitch w/seam sealant

A1 Profile Section Detail
 Scale: 1 1/2" = 1'-0"

PANELS GR8

Product ID : GR8/GR8WDS

Name : TUFF-RIB (GR8)

Description : Available with DRIPSTOP



Metal Roofing, Siding, and Trim

P: 208-565-3002
 www.ibexmetal.com
 info@ibexmetal.com

280 Great Northern Road
 Bonners Ferry, ID 83805

PANELS GR8

PROPERTY OF IBEX
 NOT FOR REPRODUCTION WITHOUT PRIOR
 WRITTEN CONSENT OF IBEX METAL, LLC

1

2

3

FRACTIONS ROUNDED TO NEAREST 1/16"
REVISED: 12/15/23

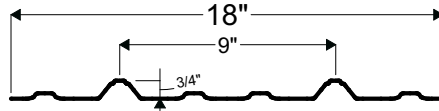

- Vented Panel available
- Match trim length requirements
- 18" Coverage
- 3/4" Rib height

A **A1** Profile Section Detail
Scale: 1 1/2"= 1'-0"

PANELS GR818
PROPERTY OF IBEX
 NOT FOR REPRODUCTION WITHOUT PRIOR
 WRITTEN CONSENT OF IBEX METAL, LLC

<i>Product ID :</i>	GR818/GR818WPERF
<i>Name :</i>	18" TUFF-RIB (GR8)
<i>Description :</i>	Soffit Panel



IBEX

IDAHO'S BEST EXTERIORS

Metal Roofing, Siding, and Trim

P: 208-565-3002
www.ibexmetal.com
info@ibexmetal.com

280 Great Northern Road
 Bonners Ferry, ID 83805

1

2

3

FRACTIONS ROUNDED TO NEAREST 1/16"
REVISED: 12/15/23

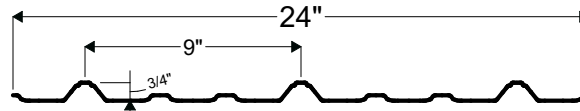

- Vented panel available
- Match trim length requirements
- 24" Coverage
- 3/4" Rib height

A1 Profile Section Detail
Scale: 1 1/2"= 1'-0"

A

A

PANELS GR824

Product ID : GR824/GR824WPERF

Name : 24" TUFF-RIB (GR8)

Description : Soffit Panel



Metal Roofing, Siding, and Trim

P: 208-565-3002
www.ibexmetal.com
info@ibexmetal.com

280 Great Northern Road
Bonners Ferry, ID 83805

PANELS GR824

PROPERTY OF IBEX
NOT FOR REPRODUCTION WITHOUT PRIOR
WRITTEN CONSENT OF IBEX METAL, LLC

1

2

3

FRACTIONS ROUNDED TO NEAREST 1/16"

REVISED: 1/12/23

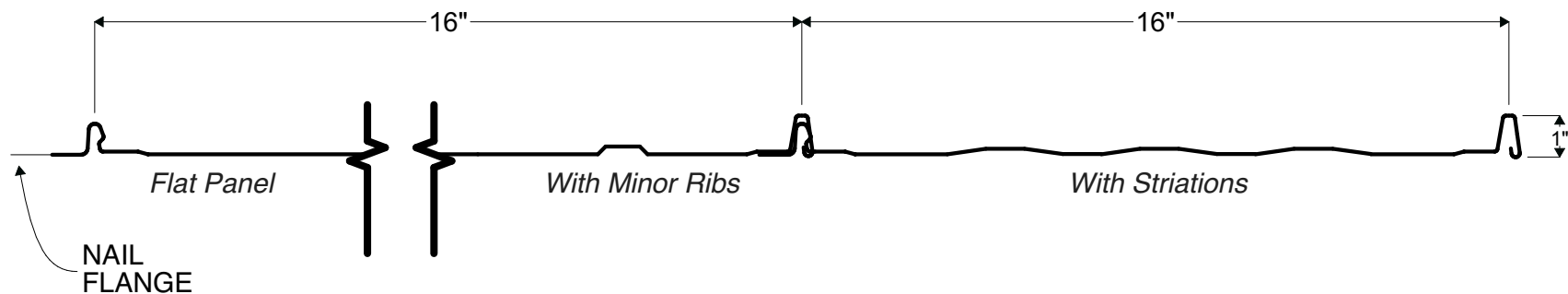

- Concealed fastener
- No MIN or MAX length requirements
- Available as pre-notched panel

- 3:12 MIN recommended roof pitch
- Striations or minor ribs recommended to reduce oil canning
- 16" Coverage • 1" Rib height
- 26ga • 24ga • 22ga

A1 Profile Section Detail

Scale: 3" = 1'-0"

PANELS 1SL

Product ID : 1SL

Name : 1" SNAPLOCK PANEL (16")

Description : Roof Panel - SnapLock Panel



Metal Roofing, Siding, and Trim

P: 208-565-3002
 www.ibexmetal.com
 info@ibexmetal.com

280 Great Northern Road
 Bonners Ferry, ID 83805

PANELS 1SL

PROPERTY OF IBEX
 NOT FOR REPRODUCTION WITHOUT PRIOR
 WRITTEN CONSENT OF IBEX METAL, LLC

FRACTIONS ROUNDED TO NEAREST 1/16"
 REVISED: 1/12/23

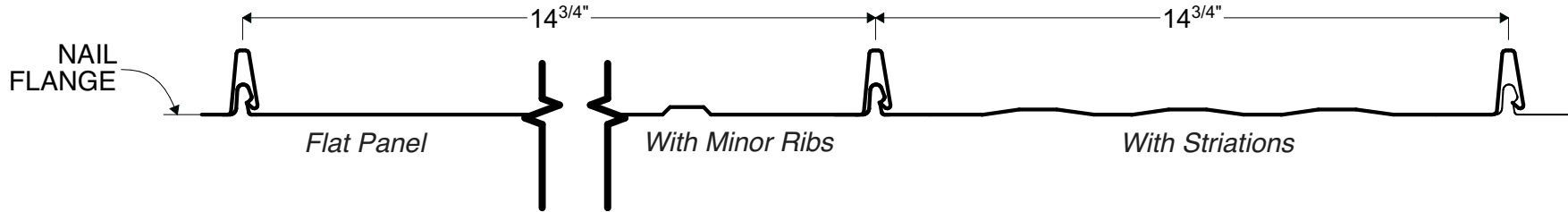

- Concealed fastener
- No MIN or MAX length requirements
- Available as pre-notched panel
- 3:12 MIN recommended roof pitch
- Striations or minor ribs recommended to reduce oil canning
- 14 3/4" Coverage • 1 1/2" Rib height
- 26ga • 24ga • 22ga

A1 Profile Section Detail
 Scale: 3" = 1'-0"

PROPERTY OF IBEX NOT FOR REPRODUCTION WITHOUT PRIOR WRITTEN CONSENT OF IBEX METAL, LLC	PANELS 15SL
	PANELS 15SL

Product ID :	15SL
Name :	1 1/2" SNAPLOCK PANEL (14 3/4")
Description :	Roof Panel - SnapLock Panel



Metal Roofing, Siding, and Trim
 P: 208-565-3002
 www.ibexmetal.com
 info@ibexmetal.com
 280 Great Northern Road
 Bonners Ferry, ID 83805

1

2

3

FRACTIONS ROUNDED TO NEAREST 1/16"
REVISED: *Work in Progress*

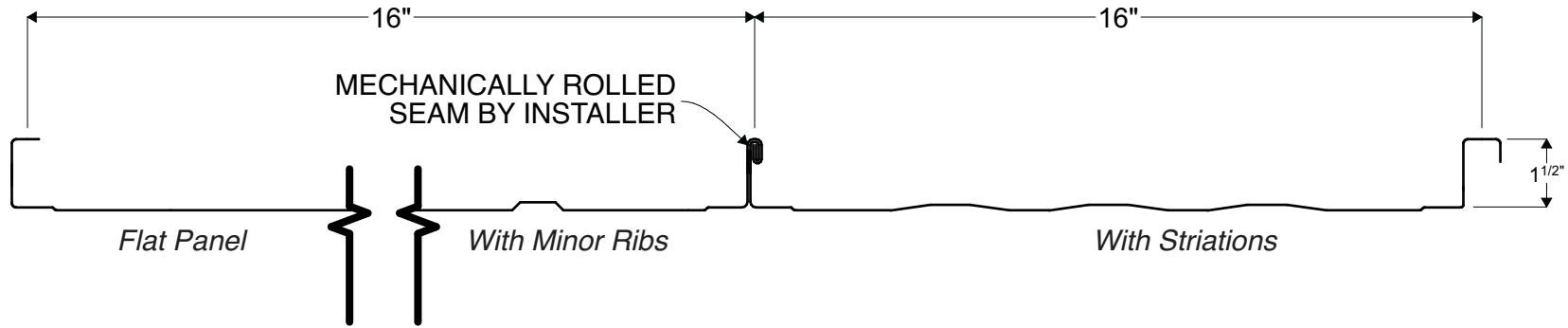

- Concealed fastener
- No MIN or MAX length requirements
- 16" Coverage
- 1.5" Seam height
- Available as pre-notched panel

- 2:12 MIN recommended roof pitch
- Striations or minor ribs recommended to reduce oil canning
- Requires seamer tool
- 26ga • 24ga • 22ga

A1 Profile Section Detail
Scale: 3" = 1'-0"

PANELS 15SS

Product ID :	15SS
Name :	1.5" STANDING SEAM (16")
Description :	Roof Panel - Standing Seam Mechanically Seamed w/Concealed Fastener



Metal Roofing, Siding, and Trim

P: 208-565-3002
www.ibexmetal.com
info@ibexmetal.com

280 Great Northern Road
Bonners Ferry, ID 83805

PANELS 15SS

PROPERTY OF IBEX
NOT FOR REPRODUCTION WITHOUT PRIOR
WRITTEN CONSENT OF IBEX METAL, LLC

1

2

3

FRACTIONS ROUNDED TO NEAREST 1/16"

REVISED: 1/12/23

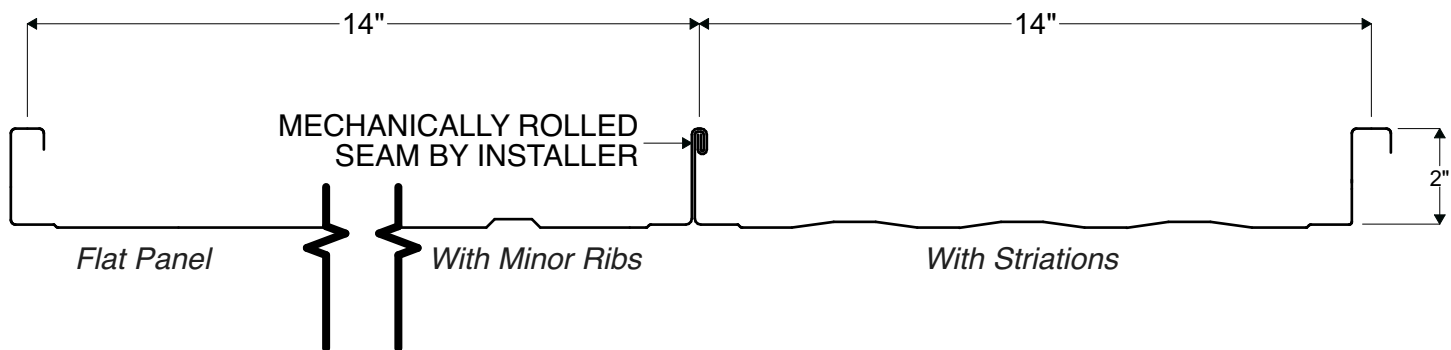

- Concealed fastener
- No MIN or MAX length requirements
- 14" Coverage
- 2" Seam height

- 2:12 MIN recommended roof pitch
- 1/2:12 MIN roof pitch w/seam sealant
- Striations or minor ribs recommended to reduce oil canning
- Requires seamer tool
- 26ga • 24ga • 22ga

A1 Profile Section Detail

Scale: 3" = 1'-0"

PANELS 2SS

Product ID : 2SS

Name : 2" STANDING SEAM STRONG LOCK (14")

Description : Roof Panel - Standing Seam
Mechanically Seamed w/Concealed Fastener

Metal Roofing, Siding, and Trim

P: 208-565-3002
www.ibexmetal.com
info@ibexmetal.com280 Great Northern Road
Bonners Ferry, ID 83805

PANELS 2SS

PROPERTY OF IBEX
NOT FOR REPRODUCTION WITHOUT PRIOR
WRITTEN CONSENT OF IBEX METAL, LLC

A

1

2

3

FRACTIONS ROUNDED TO NEAREST 1/16"
 REVISED: 4/18/23

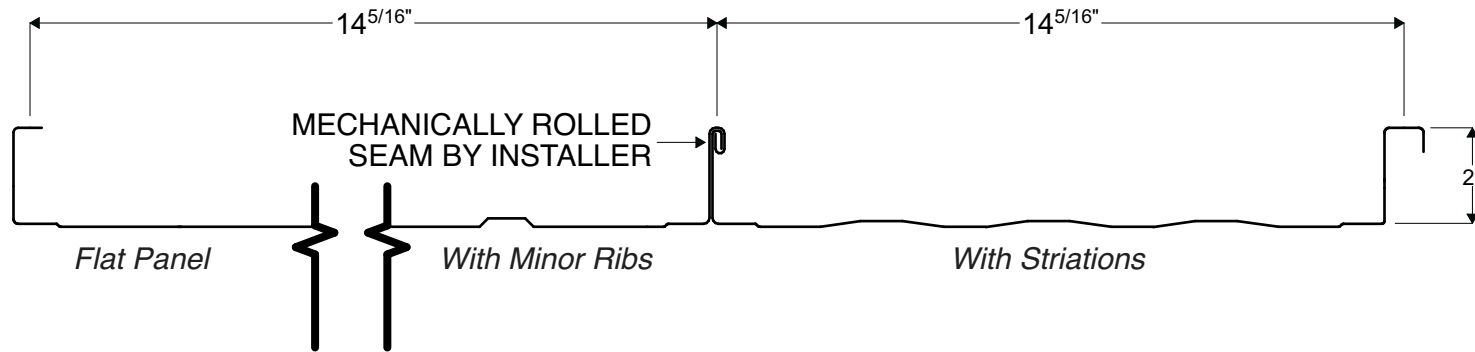

- Concealed fastener
- No MIN or MAX length requirements
- 14 ⁵/₁₆" Coverage
- 2" Seam height
- 2:12 MIN recommended roof pitch
- 1/2:12 MIN roof pitch w/seam sealant
- Striations or minor ribs recommended to reduce oil canning
- Requires seamer tool
- 26ga •24ga •22ga

A

A1 Profile Section Detail
 Scale: 3" = 1'-0"

A

PANELS 2SS

Product ID :	2SS
Name :	2" STANDING SEAM (14 5/16")
Description :	Roof Panel - Standing Seam Mechanically Seamed w/Concealed Fastener



Metal Roofing, Siding, and Trim

P: 208-565-3002
 www.ibexmetal.com
 info@ibexmetal.com

280 Great Northern Road
 Bonners Ferry, ID 83805

PANELS 2SS

PROPERTY OF IBEX
 NOT FOR REPRODUCTION WITHOUT PRIOR
 WRITTEN PERMISSION OF IBEX METAL, LLC

1

2

3

FRACTIONS ROUNDED TO NEAREST 1/16"

REVISED: 1/12/23

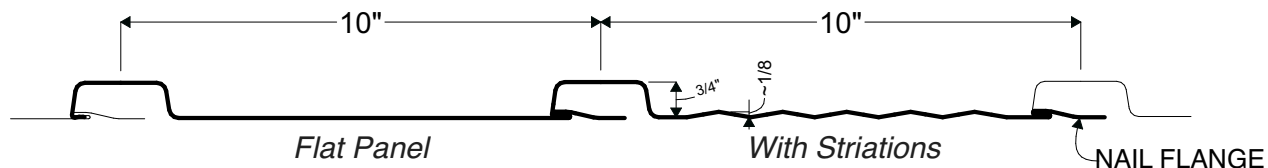

- Concealed fastener
- 36½" MIN length
- 29ga ·26ga
- Striations recommended to reduce oil canning
- 10" Coverage
- 3/4" Rib height

A

A1 Profile Section Detail

Scale: 3" = 1'-0"

A

PANELS BB

Product ID : BB/BBWS

Name : BOARD & BATTEN PANEL

Description : Siding Panel - Concealed Fastener



Metal Roofing, Siding, and Trim

P: 208-565-3002
 www.ibexmetal.com
 info@ibexmetal.com

280 Great Northern Road
 Bonners Ferry, ID 83805

PANELS BB

PROPERTY OF IBEX
 NOT FOR REPRODUCTION WITHOUT PRIOR
 WRITTEN CONSENT OF IBEX METAL, LLC

1

2

3

FRACTIONS ROUNDED TO NEAREST 1/16"
REVISED: 4/18/23

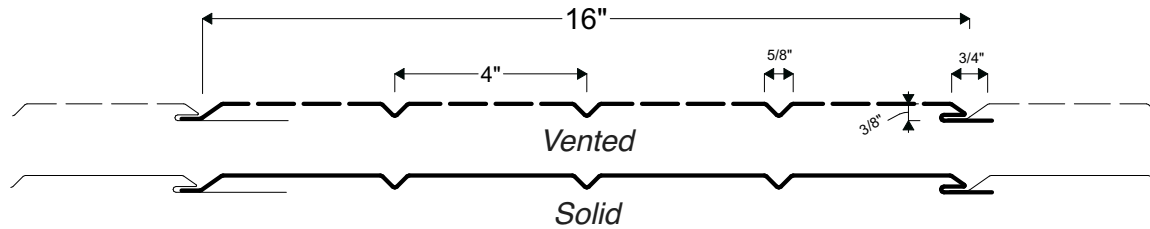

- Cut to length
- Available as solid or vented panel
- 29ga • 26ga

- 16" Coverage
- 3/8" Height

A1 Profile Section Detail
Scale: 3" = 1'-0"

PANELS SOFFIT/SOFFITVENT

Product ID : SOFFIT/SOFFITVENT

Name : SOFFIT PANEL

Description : Soffit Panel



Metal Roofing, Siding, and Trim

P: 208-565-3002
www.ibexmetal.com
info@ibexmetal.com

280 Great Northern Road
Bonners Ferry, ID 83805

PANELS SOFFIT/SOFFITVENT

PROPERTY OF IBEX
NOT FOR REPRODUCTION WITHOUT PRIOR
WRITTEN CONSENT OF IBEX METAL, LLC

A

1

2

3

FRACTIONS ROUNDED TO NEAREST 1/16"
REVISED: 7/18/23

29 | 26

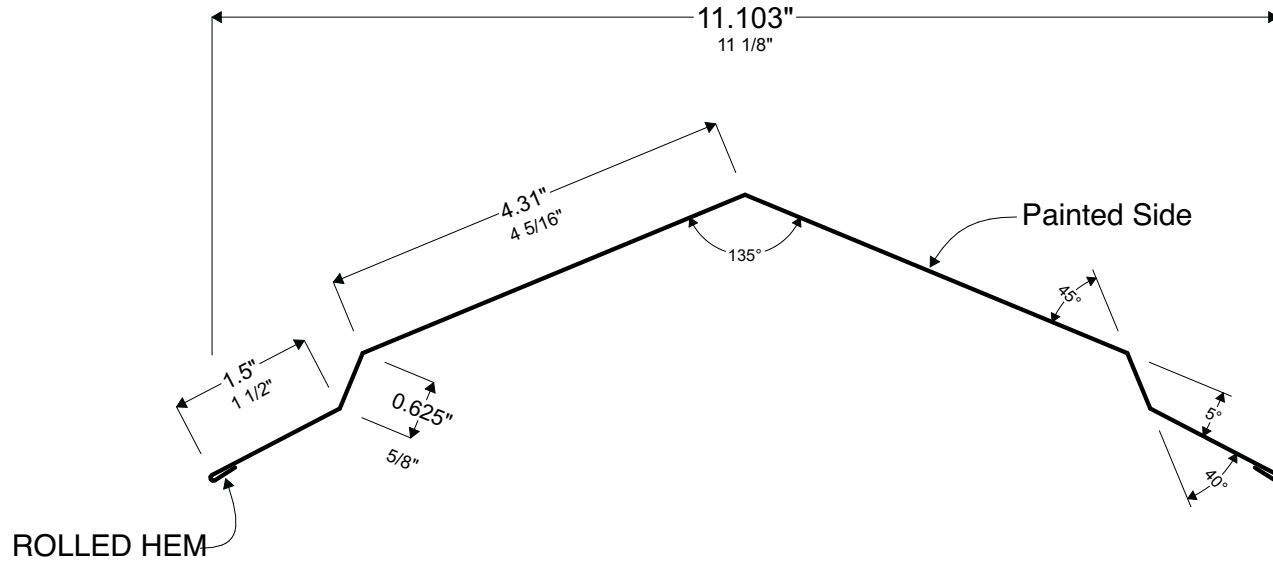

A1 Profile Section Detail
Scale: 6" = 1'-0"

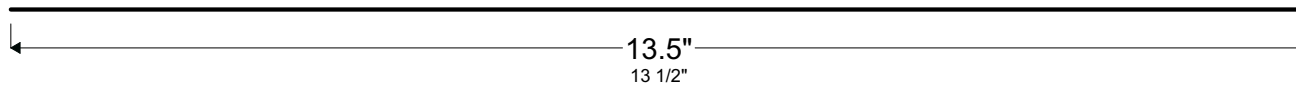

B1 Profile Flat Width Required
Scale: 6" = 1'-0"

TRIM 01 PROPERTY OF IBEX NOT FOR REPRODUCTION WITHOUT PRIOR WRITTEN CONSENT OF IBEX METAL, LLC	TRIM 01

Product ID :	01
Name :	RIDGE CAP
Description :	Ridge Cap for Roofing (Rolled)



Metal Roofing, Siding, and Trim
 P: 208-565-3002
 www.ibexmetal.com
 info@ibexmetal.com
 280 Great Northern Road
 Bonners Ferry, ID 83805

1

2

3

FRACTIONS ROUNDED TO NEAREST 1/16"
REVISED: 7/18/23

29 | 26 | 24 | 22

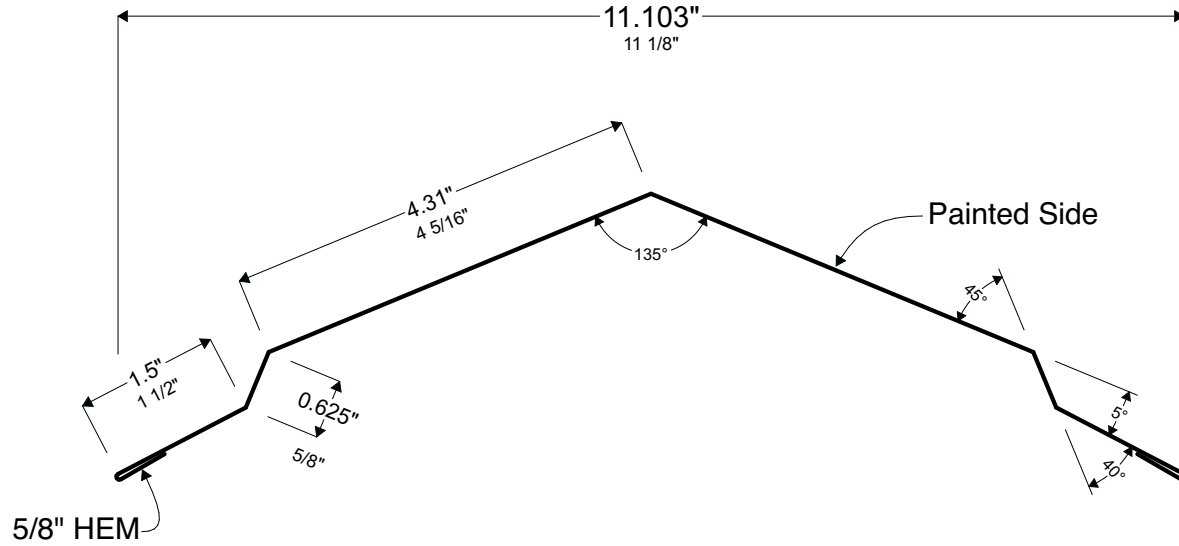

A1 Profile Section Detail
Scale: 6" = 1'-0"

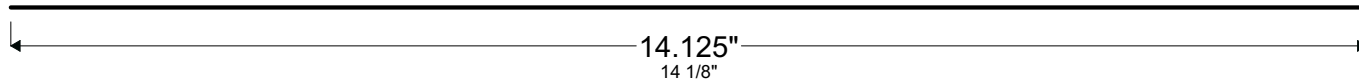

B1 Profile Flat Width Required
Scale: 6" = 1'-0"

TRIM 01F PROPERTY OF IBEX NOT FOR REPRODUCTION WITHOUT PRIOR WRITTEN PERMISSION OF IBEX METAL, LLC	TRIM 01F

Product ID :	01F
Name :	RIDGE CAP - FOLDED
Description :	Ridge Cap for Roofing



Metal Roofing, Siding, and Trim
 P: 208-565-3002
 www.ibexmetal.com
 info@ibexmetal.com
 280 Great Northern Road
 Bonners Ferry, ID 83805

1

2

3

FRACTIONS ROUNDED TO NEAREST 1/16"
REVISED: 7/18/23

29 | 26

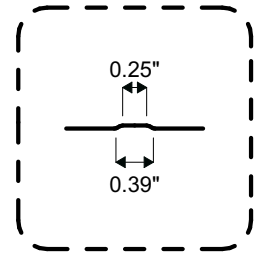
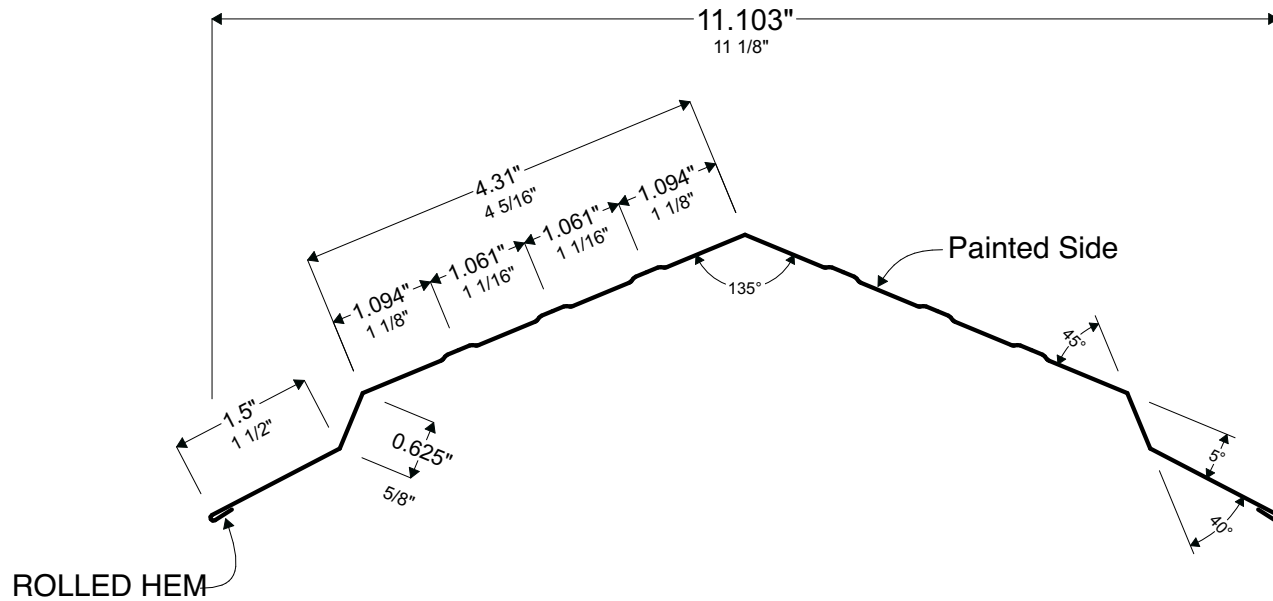

A1 Profile Section Detail
Scale: 6" = 1'-0"

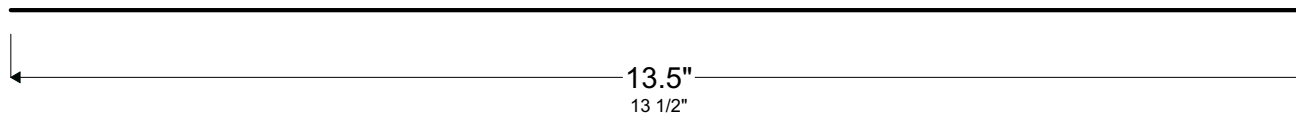

B1 Profile Flat Width Required
Scale: 6" = 1'-0"

TRIM 01R PROPERTY OF IBEX NOT FOR REPRODUCTION WITHOUT PRIOR WRITTEN PERMISSION OF IBEX METAL, LLC	TRIM 01R

Product ID :	01R
Name :	RIDGE CAP - RIBBED
Description :	Ribbed Ridge Cap for Roofing (Rolled)



Metal Roofing, Siding, and Trim
 P: 208-565-3002
 www.ibexmetal.com
 info@ibexmetal.com
 280 Great Northern Road
 Bonners Ferry, ID 83805

1

2

3

FRACTIONS ROUNDED TO NEAREST 1/16"
REVISED: 4/5/23

29 | 26 | 24 | 22

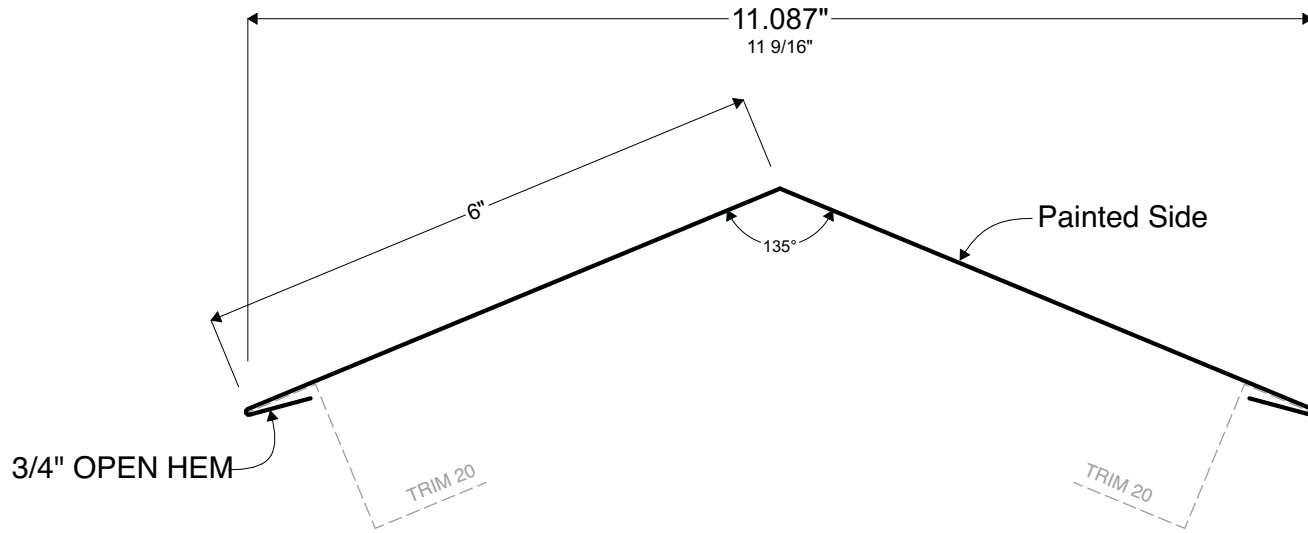

ARCHITECTURAL SERIES

A1 Profile Section Detail
Scale: 6" = 1'-0"

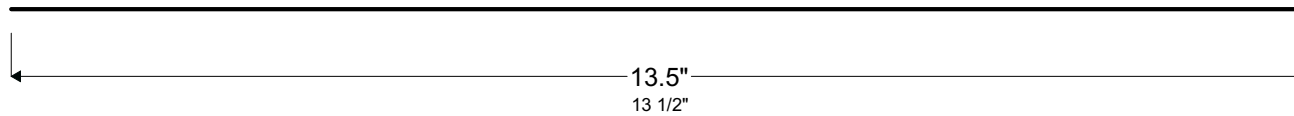

B1 Profile Flat Width Required
Scale: 6" = 1'-0"

TRIM 01B

PROPERTY OF IBEX
NOT FOR REPRODUCTION WITHOUT PRIOR
WRITTEN CONSENT OF IBEX METAL, LLC

TRIM 01B

Product ID :	01B
Name :	RIDGE CAP - ARCHITECTURAL
Description :	Ridge Cap for Concealed Fastener Roofing



Metal Roofing, Siding, and Trim
 P: 208-565-3002
 www.ibexmetal.com
 info@ibexmetal.com
 280 Great Northern Road
 Bonners Ferry, ID 83805

1

2

3

FRACTIONS ROUNDED TO NEAREST 1/16"
REVISED: 4/5/23

29 | 26 | 24 | 22

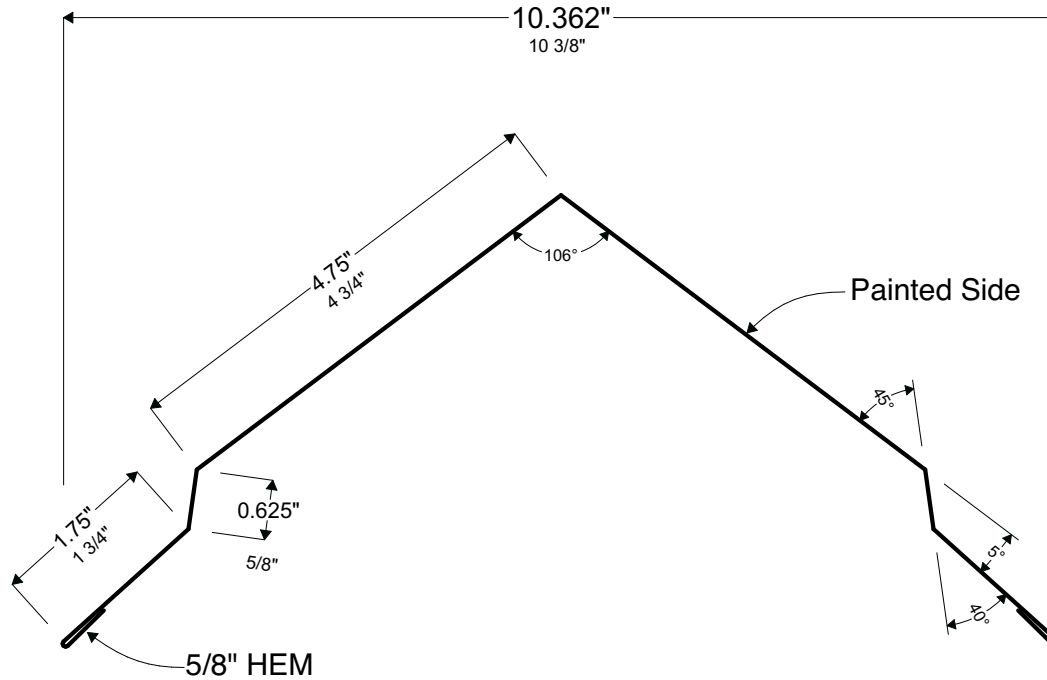

A1 Profile Section Detail
Scale: 6" = 1'-0"

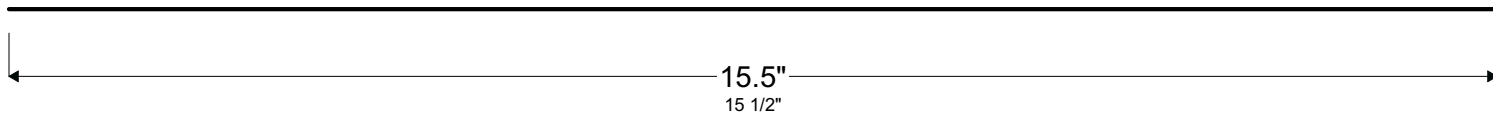

B1 Profile Flat Width Required
Scale: 6" = 1'-0"

TRIM 01C PROPERTY OF IBEX NOT FOR REPRODUCTION WITHOUT PRIOR WRITTEN PERMISSION OF IBEX METAL, LLC	TRIM 01C

Product ID :	01C
Name :	RIDGE CAP (OVERSIZE 10/12)
Description :	Oversize Ridge Cap for Roofing



Metal Roofing, Siding, and Trim
 P: 208-565-3002
 www.ibexmetal.com
 info@ibexmetal.com
 280 Great Northern Road
 Bonners Ferry, ID 83805

1

2

3

FRACTIONS ROUNDED TO NEAREST 1/16"
REVISED: 4/5/23

29 | 26 | 24 | 22

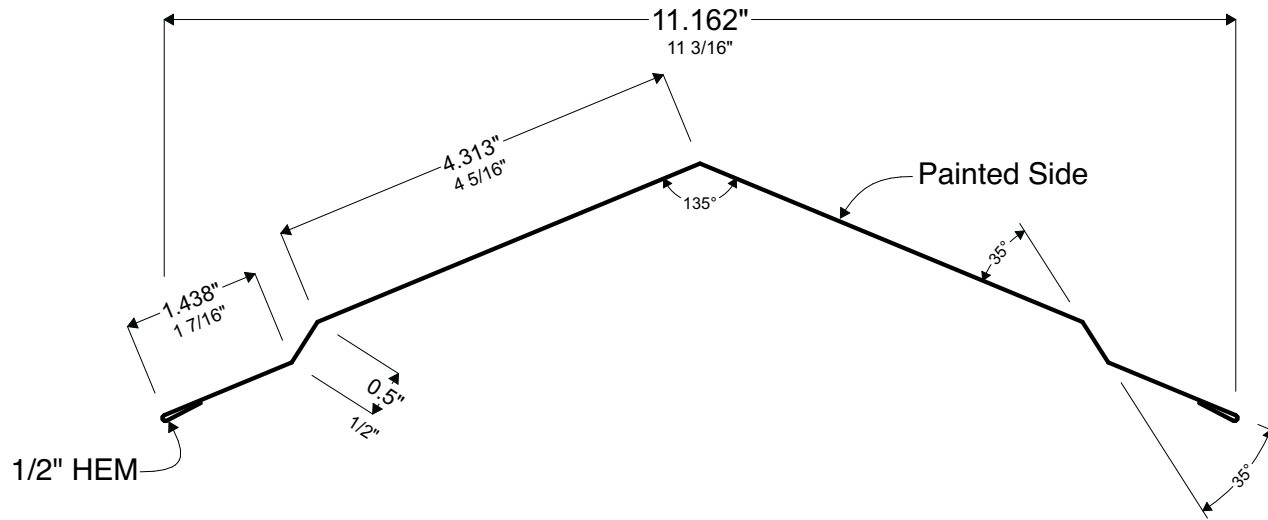

A1 Profile Section Detail
Scale: 6" = 1'-0"

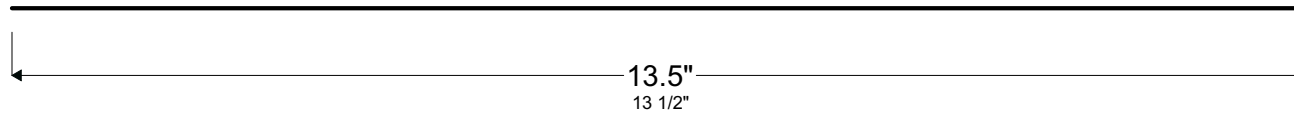

B1 Profile Flat Width Required
Scale: 6" = 1'-0"

TRIM 01H PROPERTY OF IBEX NOT FOR REPRODUCTION WITHOUT PRIOR WRITTEN PERMISSION OF IBEX METAL, LLC	TRIM 01H

Product ID :	01H
Name :	RIDGE CAP - HERITAGE
Description :	Ridge Cap for Roofing (Heritage)



Metal Roofing, Siding, and Trim
 P: 208-565-3002
 www.ibexmetal.com
 info@ibexmetal.com
 280 Great Northern Road
 Bonners Ferry, ID 83805

1

2

3

FRACTIONS ROUNDED TO NEAREST 1/16"
REVISED: 4/5/23

29 | 26 | 24 | 22

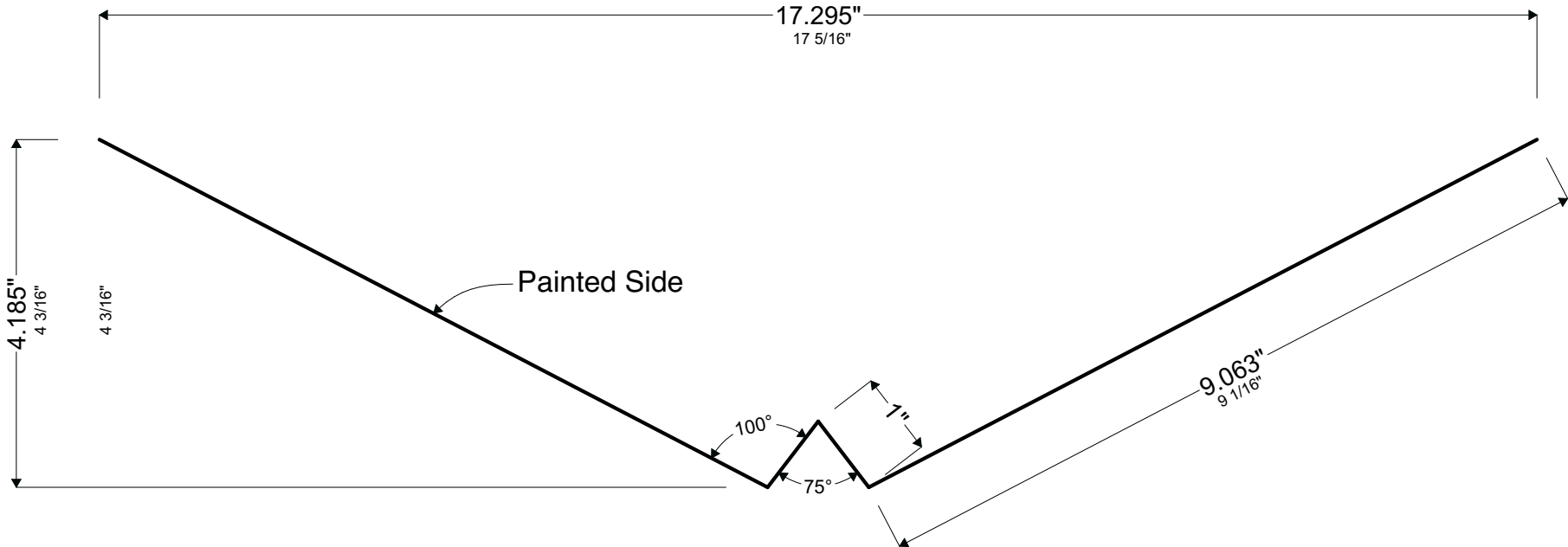

A **A1** Profile Section Detail
Scale: 6" = 1'-0"

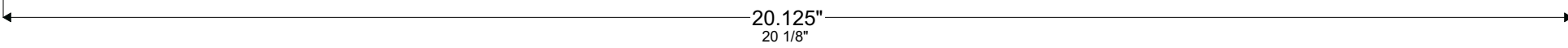

B **B1** Profile Flat Width Required
Scale: 6" = 1'-0"

TRIM 02
PROPERTY OF IBEX
 NOT FOR REPRODUCTION WITHOUT PRIOR
 WRITTEN CONSENT OF IBEX METAL, LLC

Product ID :	02
Name :	VALLEY
Description :	Valley Flashing



IBEX

IDAHO'S BEST EXTERIORS

Metal Roofing, Siding, and Trim

P: 208-565-3002
www.ibexmetal.com
info@ibexmetal.com

280 Great Northern Road
 Bonners Ferry, ID 83805

1 2 3

FRACTIONS ROUNDED TO NEAREST 1/16"
 REVISED: 4/5/23

29 | 26*

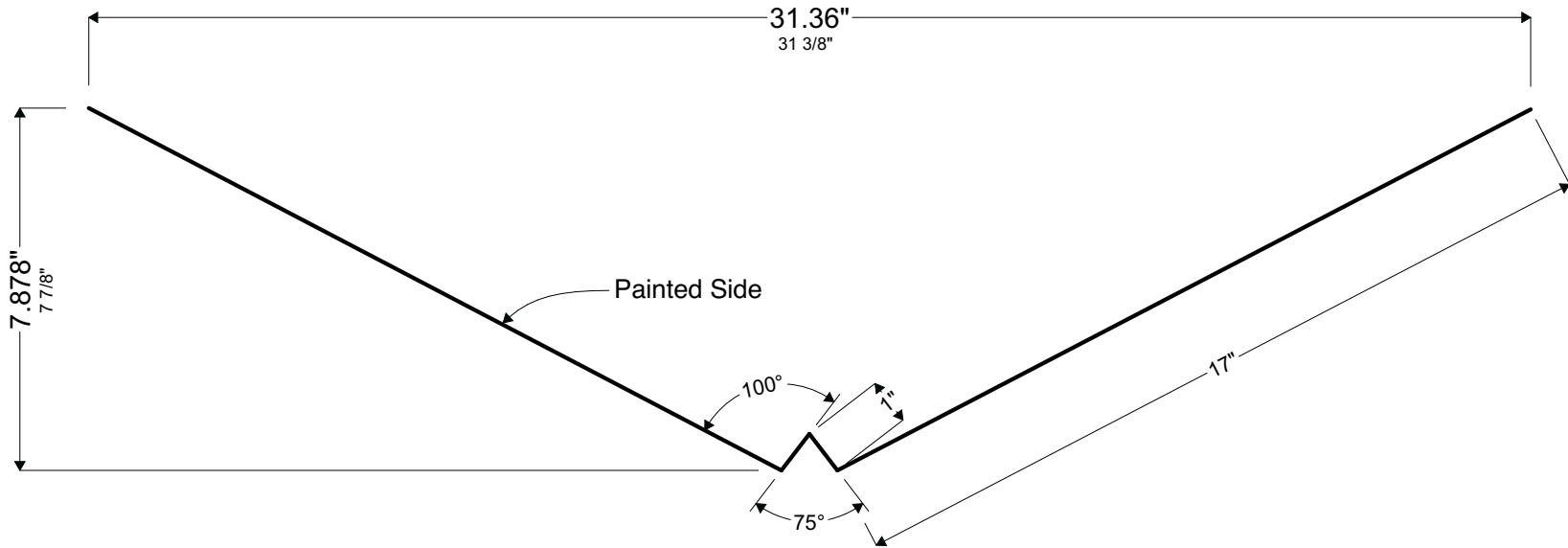

A1 Profile Section Detail
 Scale: 3" = 1'-0"

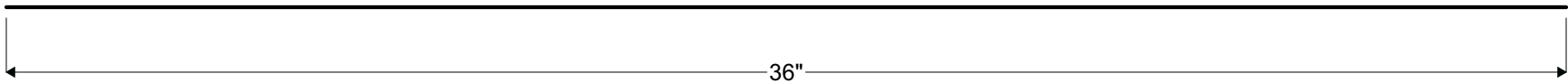

B1 Profile Flat Width Required
 Scale: 3" = 1'-0"

TRIM 02B

PROPERTY OF IBEX
 NOT FOR REPRODUCTION WITHOUT PRIOR
 WRITTEN CONSENT OF IBEX METAL, LLC

TRIM 02B

Product ID :	02B
Name :	JUMBO VALLEY
Description :	Extra Wide Valley Flashing



Metal Roofing, Siding, and Trim
 P: 208-565-3002
 www.ibexmetal.com
 info@ibexmetal.com
 280 Great Northern Road
 Bonners Ferry, ID 83805

1

2

3

FRACTIONS ROUNDED TO NEAREST 1/16"
REVISED: 12/12/23

29 | 26 | 24

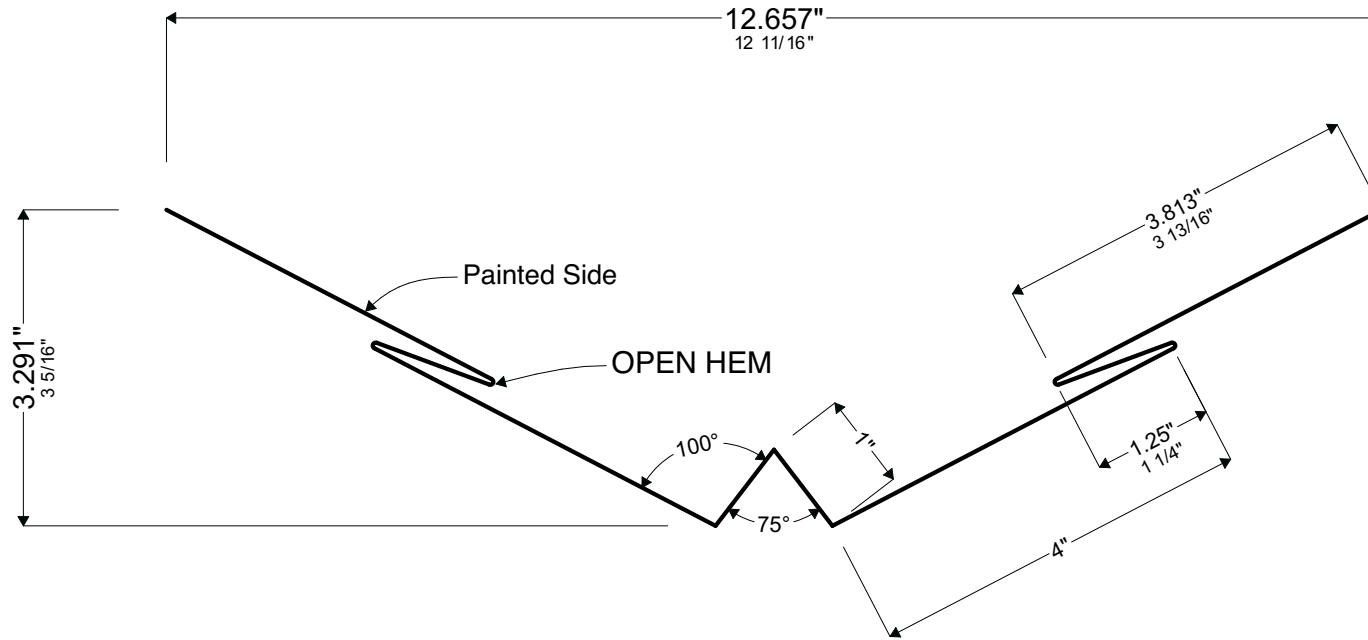

ARCHITECTURAL SERIES

A1 Profile Section Detail
Scale: 6" = 1'-0"

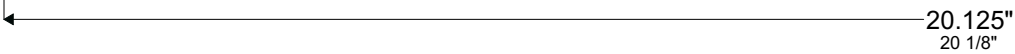

B1 Profile Flat Width Required
Scale: 6" = 1'-0"

TRIM 02C

Product ID :	02C
Name :	CLEATED VALLEY
Description :	Valley Flashing for Concealed Fastener



Metal Roofing, Siding, and Trim

P: 208-565-3002
www.ibexmetal.com
info@ibexmetal.com

280 Great Northern Road
Bonners Ferry, ID 83805

TRIM 02C

PROPERTY OF IBEX
NOT FOR REPRODUCTION WITHOUT PRIOR
WRITTEN PERMISSION OF IBEX METAL, LLC

FRACTIONS ROUNDED TO NEAREST 1/16"
 REVISED: 12/12/23

29 | 26* | 24*

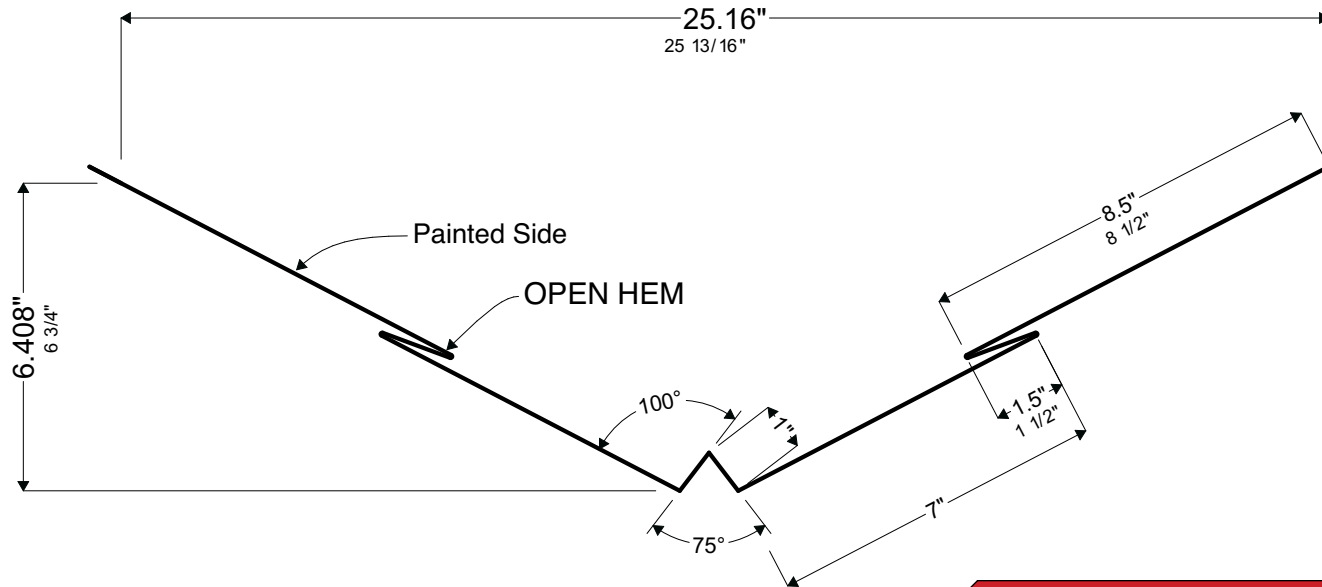

ARCHITECTURAL SERIES

A1 Profile Section Detail
 Scale: 3" = 1'-0"

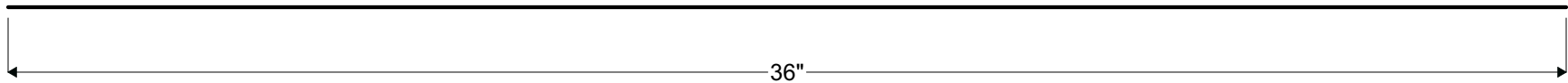

B1 Profile Flat Width Required
 Scale: 3" = 1'-0"

TRIM 02D PROPERTY OF IBEX NOT FOR REPRODUCTION WITHOUT PRIOR WRITTEN PERMISSION OF IBEX METAL, LLC TRIM 02D	TRIM 02D
---	----------

Product ID :	02D
Name :	JUMBO CLEATED VALLEY
Description :	Extra Wide Valley for Concealed Fastener



Metal Roofing, Siding, and Trim
 P: 208-565-3002
 www.ibexmetal.com
 info@ibexmetal.com
 280 Great Northern Road
 Bonners Ferry, ID 83805

FRACTIONS ROUNDED TO NEAREST 1/16"
 REVISED: 4/5/23

29 | 26 | 24 | 22

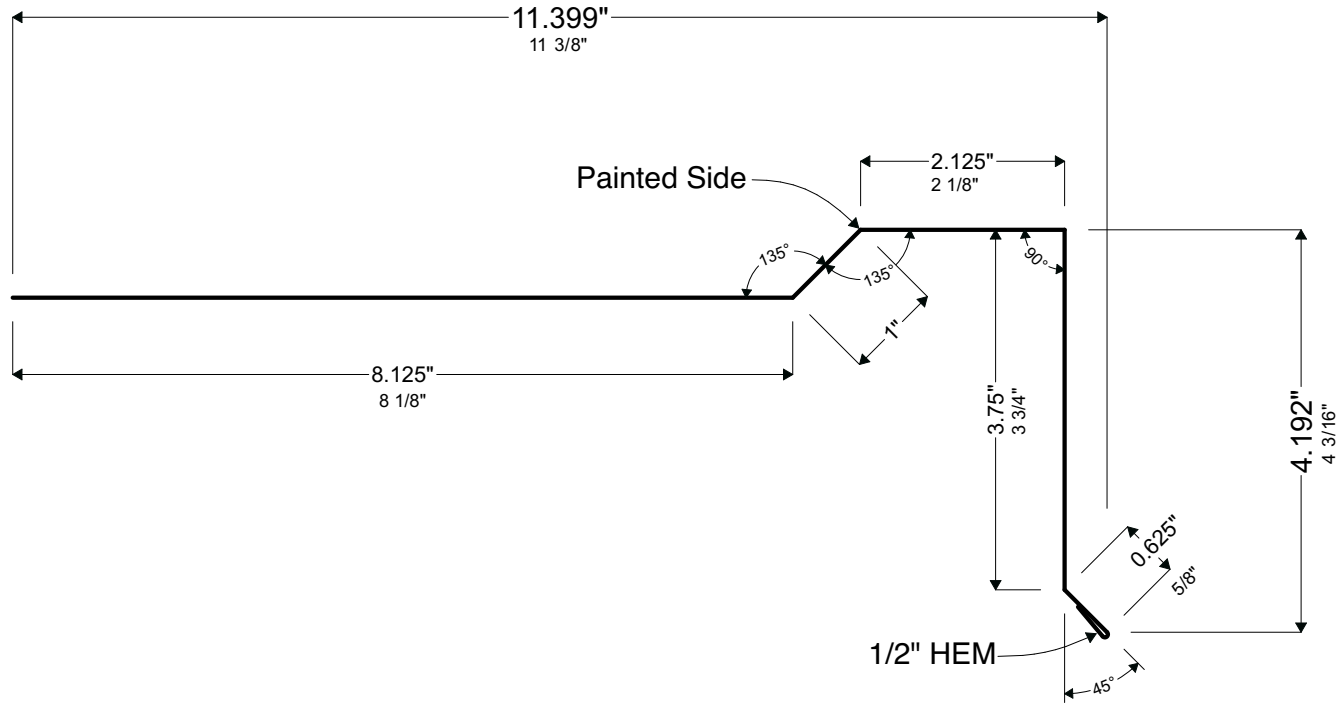

A1 Profile Section Detail
 Scale: 6" = 1'-0"

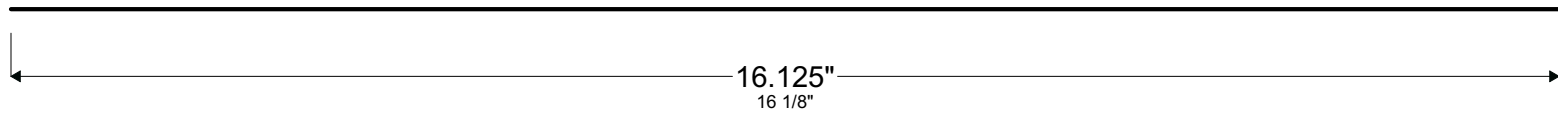

B1 Profile Flat Width Required
 Scale: 6" = 1'-0"

TRIM 03 NOT FOR REPRODUCTION WITHOUT PRIOR WRITTEN PERMISSION OF IBEX METAL, LLC PROPERTY OF IBEX	TRIM 03
---	----------------

Product ID :	03
Name :	PROW FLASHING
Description :	Trim/Flashing for Angled (Prow) Gable



Metal Roofing, Siding, and Trim

P: 208-565-3002
 www.ibexmetal.com
 info@ibexmetal.com

280 Great Northern Road
 Bonners Ferry, ID 83805

IDAHO'S BEST EXTERIORS

FRACTIONS ROUNDED TO NEAREST 1/16"
 REVISED: 12/12/23

29 | 26 | 24 | 22

UPPER

- 12:12 = 135.00°
- 11:12 = 137.49°
- 10:12 = 140.19°
- 9:12 = 143.13°
- 8:12 = 146.31°
- 7:12 = 159.74°
- 6:12 = 153.43°
- 5:12 = 157.38°
- 4:12 = 161.57°
- 3:12 = 165.96°
- 2:12 = 170.54°
- 1:12 = 175.24°
- 0:12 = 180.00°

LOWER

- 0:12 = 00.00°
- 1:12 = 04.76°
- 2:12 = 09.46°
- 3:12 = 14.04°
- 4:12 = 18.43°
- 5:12 = 22.62°
- 6:12 = 26.57°
- 7:12 = 20.26°
- 8:12 = 33.69°
- 9:12 = 36.87°
- 10:12 = 39.81°
- 11:12 = 42.51°
- 12:12 = 45.00°

PITCH BREAK FLASHING ANGLES:
 UPPER ANGLE° + LOWER ANGLE° = PITCH BREAK ANGLE°

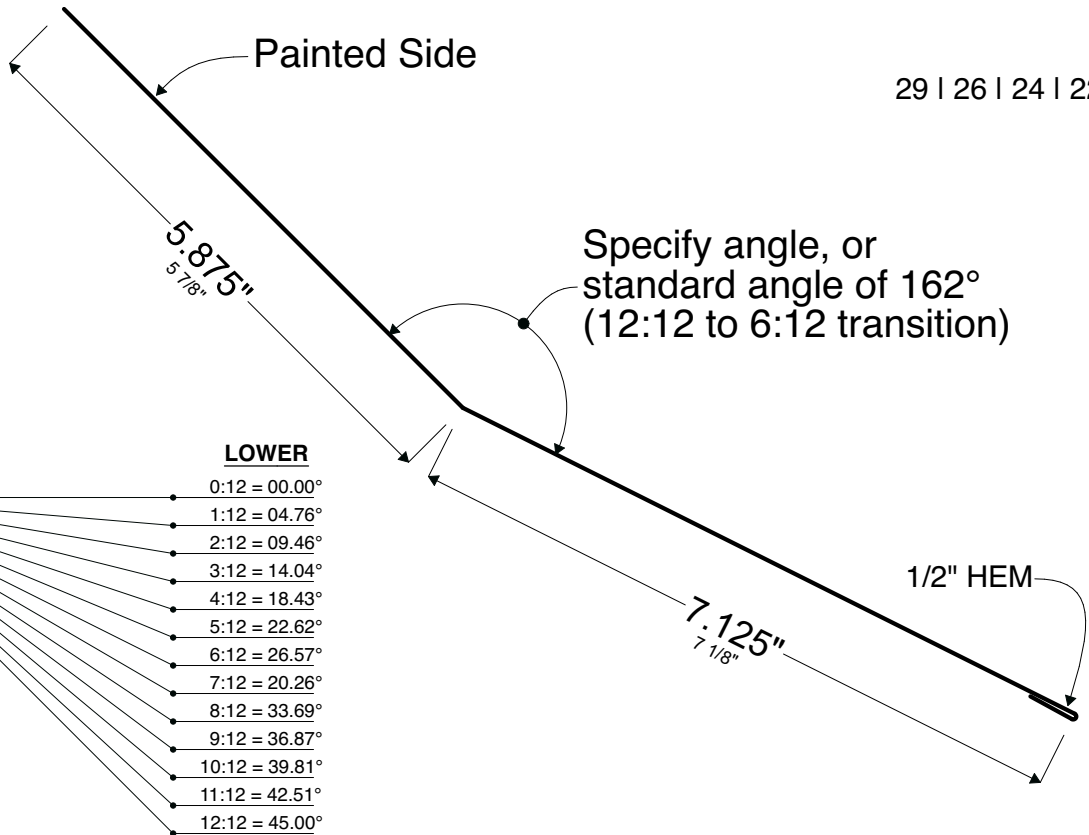

A1 Profile Section Detail
 Scale: 6" = 1'-0"

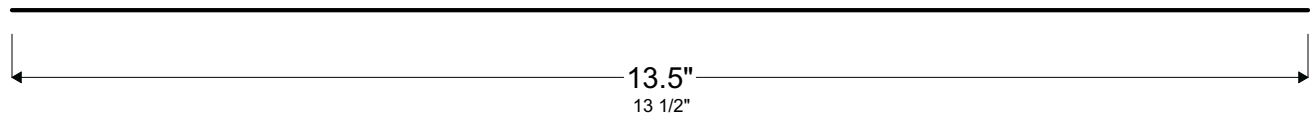

B1 Profile Flat Width Required
 Scale: 6" = 1'-0"

TRIM 04 PROPERTY OF IBEX NOT FOR REPRODUCTION WITHOUT PRIOR WRITTEN CONSENT OF IBEX METAL, LLC	TRIM 04

Product ID :	04
Name :	PITCH BREAK (TRANSITION)
Description :	Pitch Break Transition



Metal Roofing, Siding, and Trim
 P: 208-565-3002
 www.ibexmetal.com
 info@ibexmetal.com
 280 Great Northern Road
 Bonners Ferry, ID 83805

FRACTIONS ROUNDED TO NEAREST 1/16"
 REVISED: 12/12/23

29 | 26 | 24 | 22

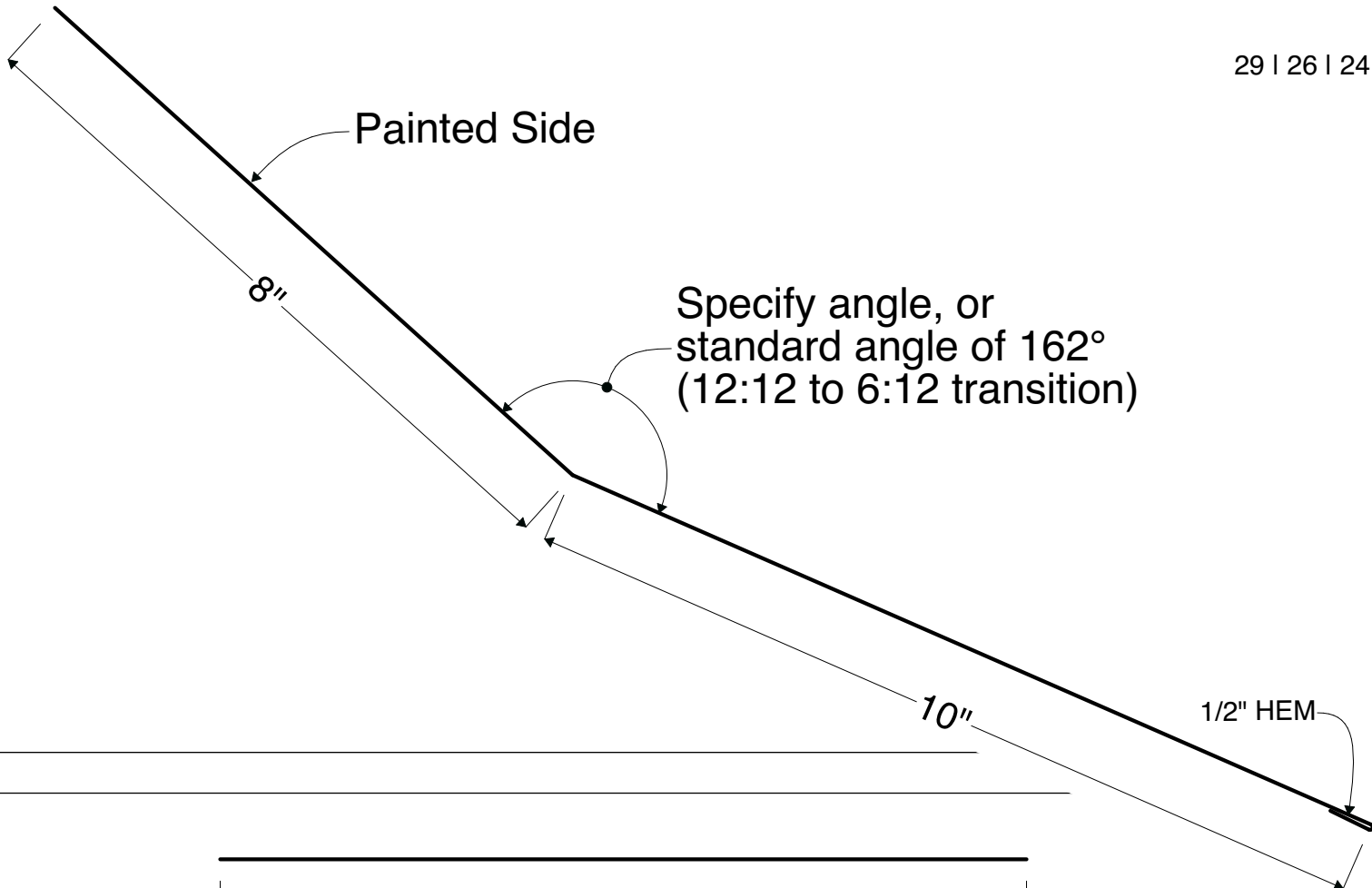

A1 Profile Section Detail
 Scale: 6" = 1'-0"

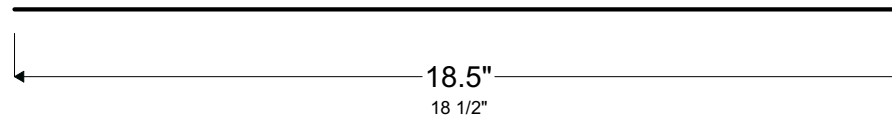

B1 Profile Flat Width Required
 Scale: 6" = 1'-0"

TRIM 04B

PROPERTY OF IBEX
 NOT FOR REPRODUCTION WITHOUT PRIOR
 WRITTEN CONSENT OF IBEX METAL, LLC

TRIM 04B

<i>Product ID :</i>	04B
<i>Name :</i>	JUMBO PITCH BREAK (TRANSITION)
<i>Description :</i>	Jumbo Pitch Break



Metal Roofing, Siding, and Trim
 P: 208-565-3002
 www.ibexmetal.com
 info@ibexmetal.com
 280 Great Northern Road
 Bonners Ferry, ID 83805

FRACTIONS ROUNDED TO NEAREST 1/16"
 REVISED: 12/12/23

29 | 26 | 24 | 22

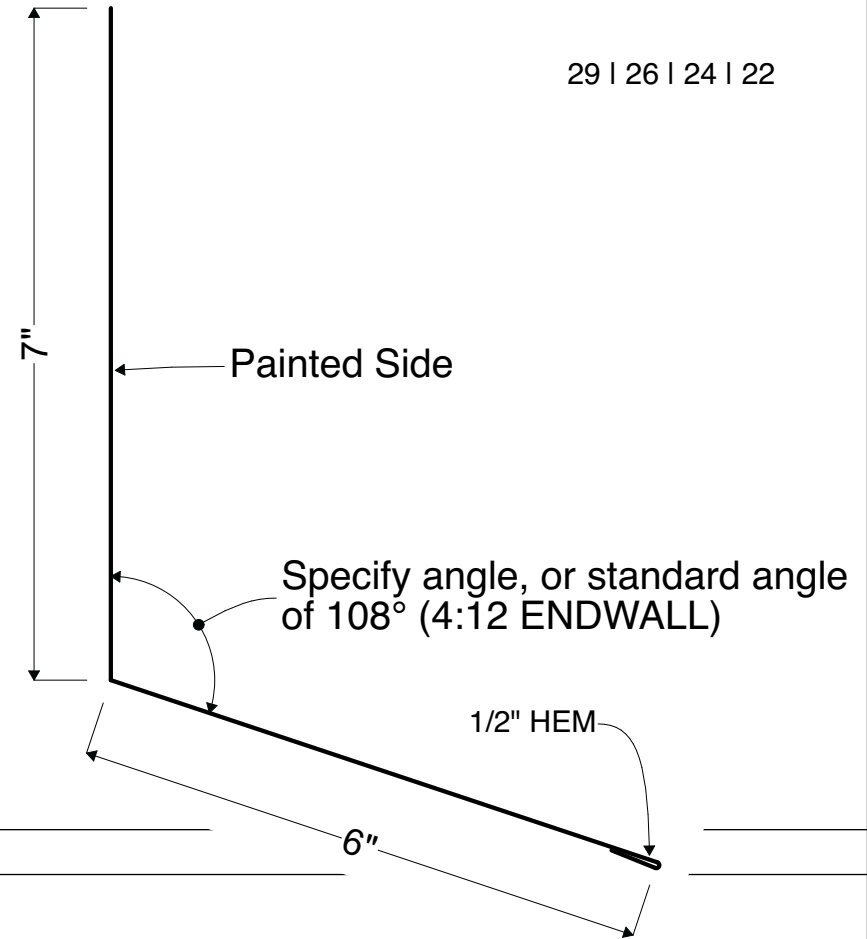
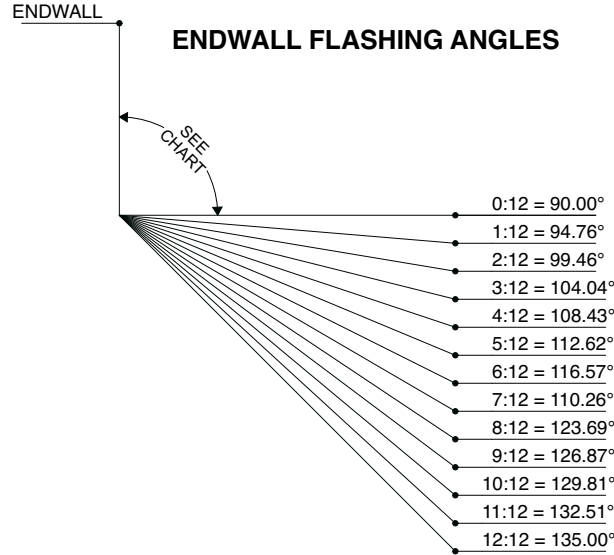

A1 Profile Section Detail
 Scale: 6" = 1'-0"

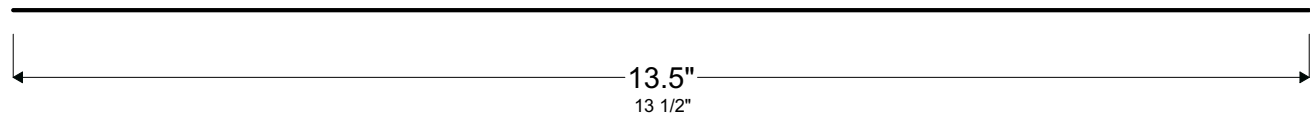

B1 Profile Flat Width Required
 Scale: 6" = 1'-0"

TRIM 04C
PROPERTY OF IBEX
 NOT FOR REPRODUCTION WITHOUT PRIOR
 WRITTEN PERMISSION OF IBEX METAL, LLC
TRIM 04C

Product ID :	04C
Name :	ENDWALL
Description :	Endwall flashing

IBEX
 IDAHO'S BEST EXTERIORS

Metal Roofing, Siding, and Trim
 P: 208-565-3002
 www.ibexmetal.com
 info@ibexmetal.com
 280 Great Northern Road
 Bonners Ferry, ID 83805

1

2

3

FRACTIONS ROUNDED TO NEAREST 1/16"
REVISED: 12/12/23

29 | 26 | 24 | 22

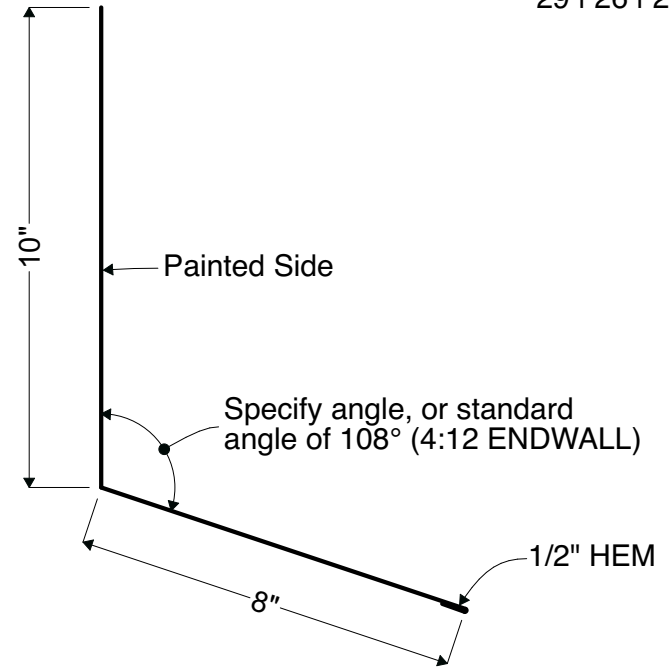
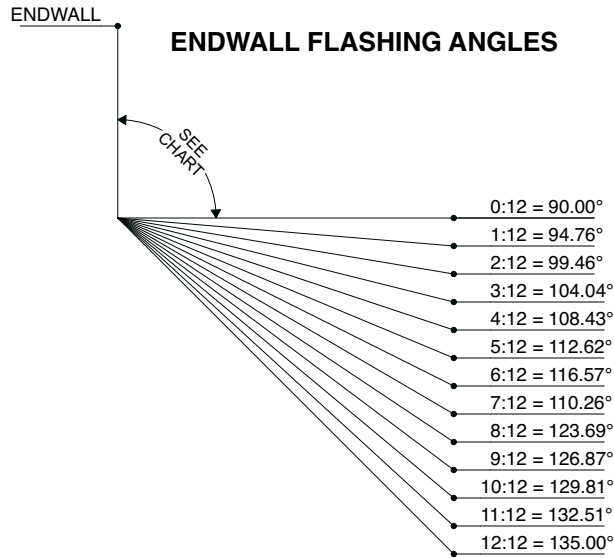

A **A1** Profile Section Detail
Scale: 3" = 1'-0"

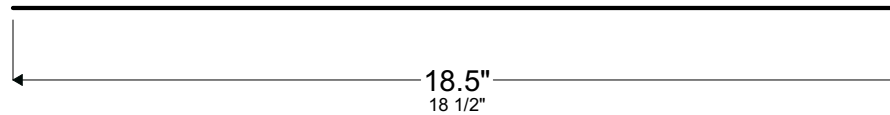

B **B1** Profile Flat Width Required
Scale: 3" = 1'-0"

TRIM 04D

PROPERTY OF IBEX
NOT FOR REPRODUCTION WITHOUT PRIOR WRITTEN PERMISSION OF IBEX METAL, LLC

TRIM 04D

Product ID :	04D
Name :	JUMBO ENDWALL
Description :	Jumbo Endwall Flashing



Metal Roofing, Siding, and Trim
P: 208-565-3002
www.ibexmetal.com
info@ibexmetal.com
280 Great Northern Road
Bonners Ferry, ID 83805

1

2

3

FRACTIONS ROUNDED TO NEAREST 1/16"
REVISED: 12/12/23

29 | 26 | 24 | 22

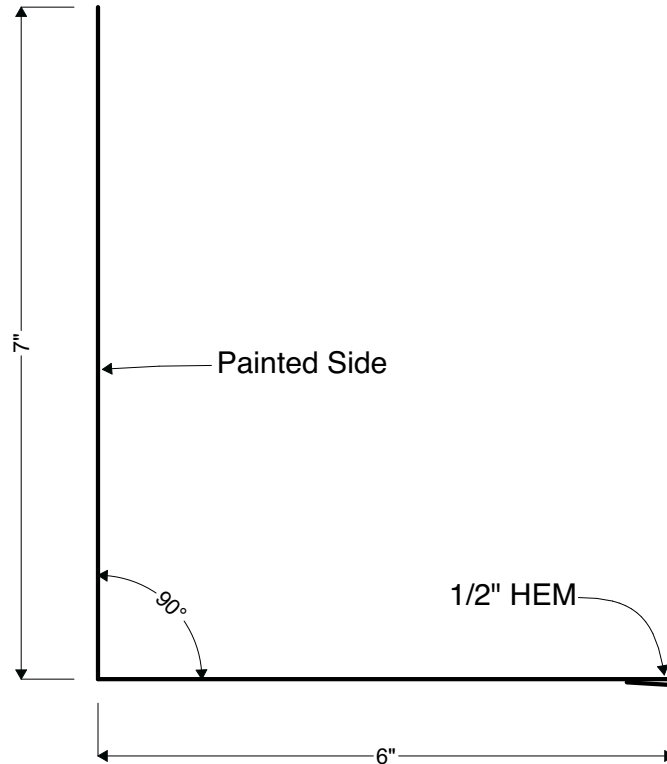

A1 Profile Section Detail
Scale: 6" = 1'-0"

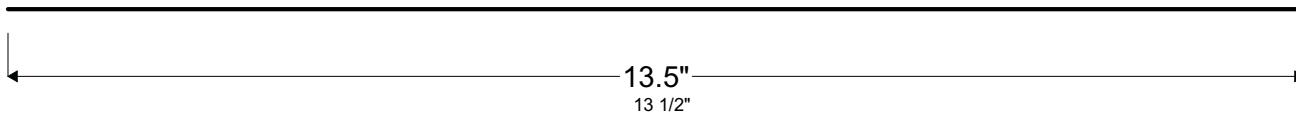

B1 Profile Flat Width Required
Scale: 6" = 1'-0"

TRIM 04E PROPERTY OF IBEX NOT FOR REPRODUCTION WITHOUT PRIOR WRITTEN CONSENT OF IBEX METAL, LLC	TRIM 04E

Product ID :	04E
Name :	SIDEWALL
Description :	Sidewall Flashing



Metal Roofing, Siding, and Trim
 P: 208-565-3002
 www.ibexmetal.com
 info@ibexmetal.com
 280 Great Northern Road
 Bonners Ferry, ID 83805

TRIM 04E

1

2

3

FRACTIONS ROUNDED TO NEAREST 1/16"
REVISED: 12/12/23

29 | 26 | 24 | 22

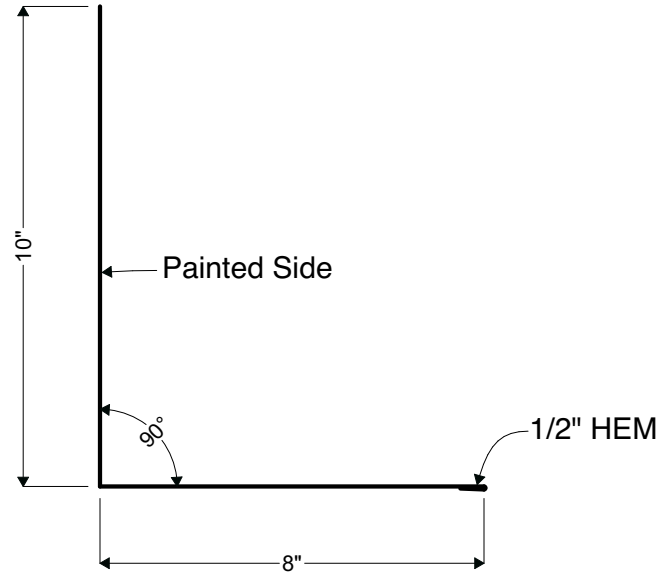

A1 Profile Section Detail
Scale: 3" = 1'-0"

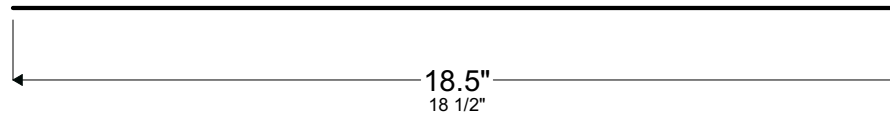

B1 Profile Flat Width Required
Scale: 3" = 1'-0"

TRIM 04F

PROPERTY OF IBEX
NOT FOR REPRODUCTION WITHOUT PRIOR
WRITTEN CONSENT OF IBEX METAL, LLC

TRIM 04F

Product ID :	04F
Name :	JUMBO SIDEWALL
Description :	Jumbo Sidewall Flashing



Metal Roofing, Siding, and Trim
 P: 208-565-3002
 www.ibexmetal.com
 info@ibexmetal.com
 280 Great Northern Road
 Bonners Ferry, ID 83805

1

2

3

FRACTIONS ROUNDED TO NEAREST 1/16"
REVISED: 12/12/23

29 | 26 | 24 | 22

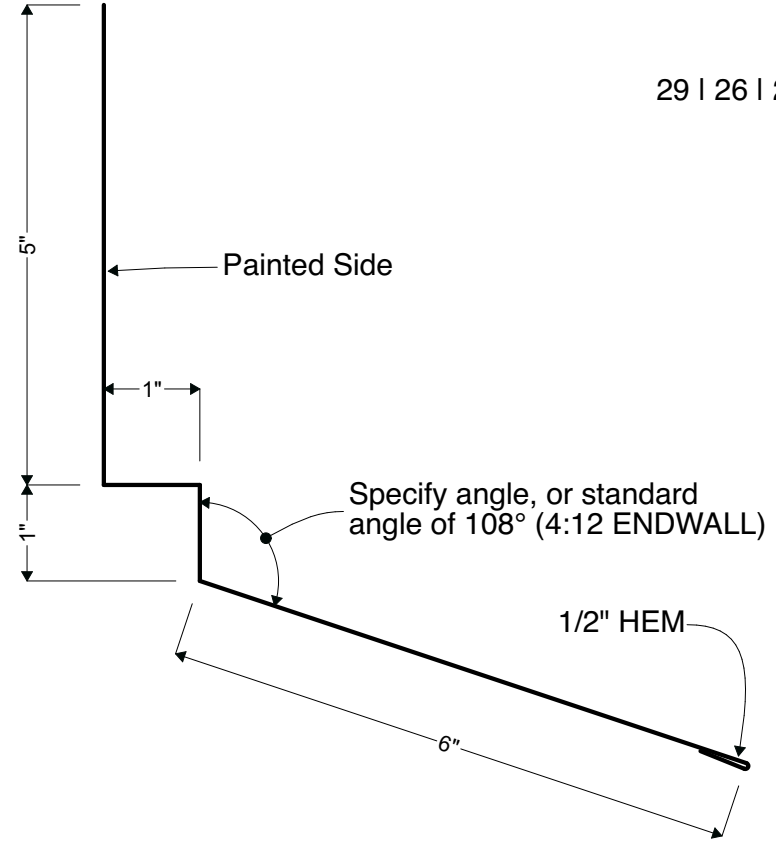
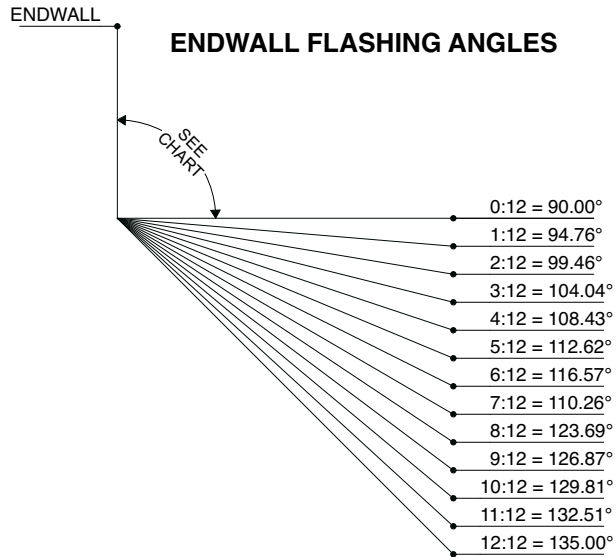

A1 Profile Section Detail
Scale: 6" = 1'-0"

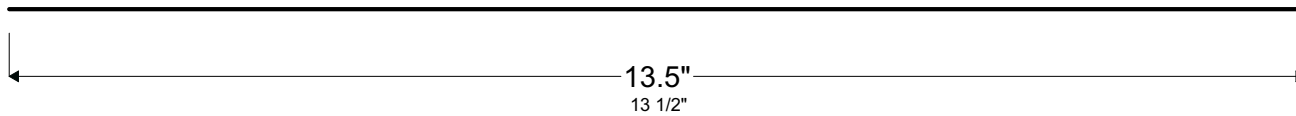

B1 Profile Flat Width Required
Scale: 6" = 1'-0"

TRIM 04J

PROPERTY OF IBEX
NOT FOR REPRODUCTION WITHOUT PRIOR
WRITTEN PERMISSION OF IBEX METAL, LLC

Product ID :	04J
Name :	STEPPED ENDWALL
Description :	Endwall Flashing w/Step



Metal Roofing, Siding, and Trim
 P: 208-565-3002
 www.ibexmetal.com
 info@ibexmetal.com
 280 Great Northern Road
 Bonners Ferry, ID 83805

1

2

3

FRACTIONS ROUNDED TO NEAREST 1/16"
REVISED: 12/12/23

29 | 26 | 24 | 22

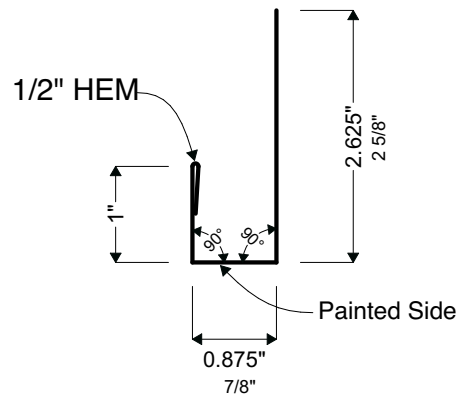

A **A1** Profile Section Detail
Scale: 6" = 1'-0"

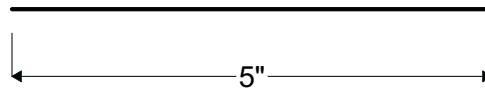

B **B1** Profile Flat Width Required
Scale: 6" = 1'-0"

TRIM 05 PROPERTY OF IBEX NOT FOR REPRODUCTION WITHOUT PRIOR WRITTEN CONSENT OF IBEX METAL, LLC	TRIM 05

<i>Product ID :</i>	05
<i>Name :</i>	J-CHANNEL
<i>Description :</i>	J-Channel Trim



Metal Roofing, Siding, and Trim
 P: 208-565-3002
 www.ibexmetal.com
 info@ibexmetal.com
 280 Great Northern Road
 Bonners Ferry, ID 83805

1

2

3

FRACTIONS ROUNDED TO NEAREST 1/16"
REVISED: 12/12/23

29 | 26 | 24

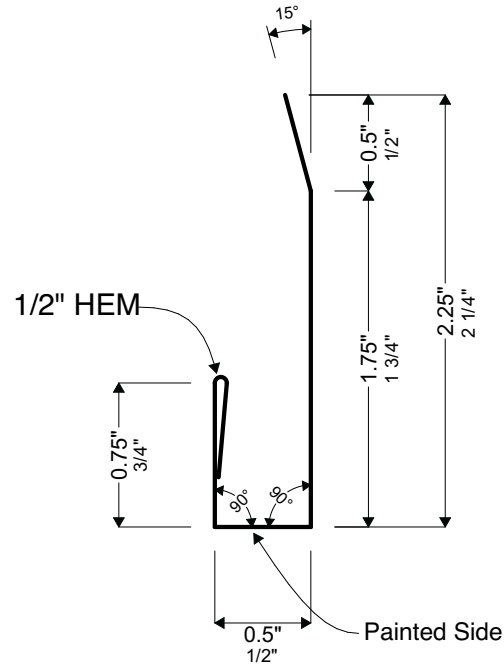

A1 Profile Section Detail
Scale: 1' = 1'-0"

B1 Profile Flat Width Required
Scale: 1' = 1'-0"

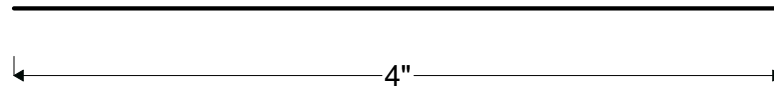

TRIM 05B PROPERTY OF IBEX NOT FOR REPRODUCTION WITHOUT PRIOR WRITTEN CONSENT OF IBEX METAL, LLC	TRIM 05B

Product ID :	05B
Name :	MINI J-CHANNEL
Description :	Small J-Channel - Typically Used With Soffit



Metal Roofing, Siding, and Trim
 P: 208-565-3002
 www.ibexmetal.com
 info@ibexmetal.com
 280 Great Northern Road
 Bonners Ferry, ID 83805

1

2

3

FRACTIONS ROUNDED TO NEAREST 1/16"
REVISED: 12/12/23

29 | 26

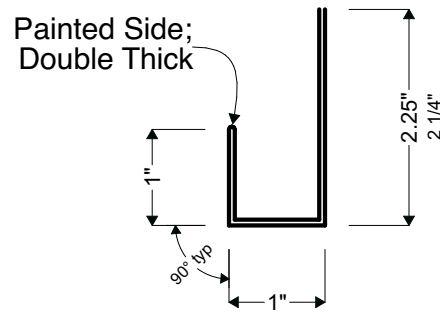

ARCHITECTURAL SERIES

A1 Profile Section Detail
Scale: 6" = 1'-0"



B1 Profile Flat Width Required
Scale: 6" = 1'-0"

TRIM 05C

PROPERTY OF IBEX
NOT FOR REPRODUCTION WITHOUT PRIOR
WRITTEN PERMISSION OF IBEX METAL, LLC

TRIM 05C

<i>Product ID :</i>	05C
<i>Name :</i>	FULL WRAP J-CHANNEL
<i>Description :</i>	2-Sided J-Channel



Metal Roofing, Siding, and Trim
 P: 208-565-3002
 www.ibexmetal.com
 info@ibexmetal.com
 280 Great Northern Road
 Bonners Ferry, ID 83805

1

2

3

FRACTIONS ROUNDED TO NEAREST 1/16"
REVISED: 4/5/23

29 | 26 | 24 | 22

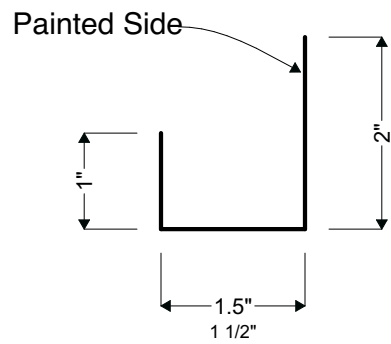

ARCHITECTURAL SERIES

A1 Profile Section Detail
Scale: 6" = 1'-0"

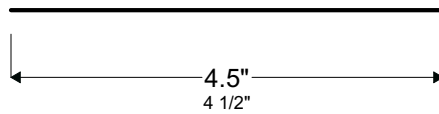

B1 Profile Flat Width Required
Scale: 6" = 1'-0"

TRIM 05D

<i>Product ID :</i>	05D
<i>Name :</i>	REVERSE OVERSIZE J-CHANNEL
<i>Description :</i>	Large J-Channel with Color Inside



Metal Roofing, Siding, and Trim
 P: 208-565-3002
 www.ibexmetal.com
 info@ibexmetal.com
 280 Great Northern Road
 Bonners Ferry, ID 83805

TRIM 05D

PROPERTY OF IBEX
NOT FOR REPRODUCTION WITHOUT PRIOR
WRITTEN CONSENT OF IBEX METAL, LLC

1

2

3

FRACTIONS ROUNDED TO NEAREST 1/16"
REVISED: 12/12/23

29 | 26 | 24 | 22

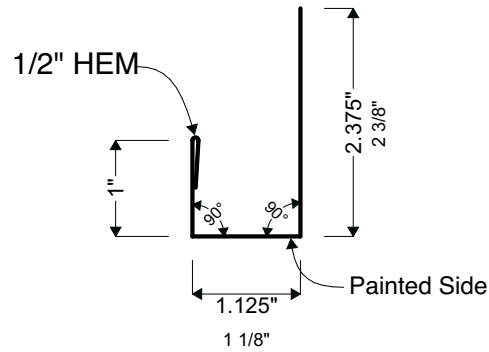

A1 Profile Section Detail
Scale: 6" = 1'-0"

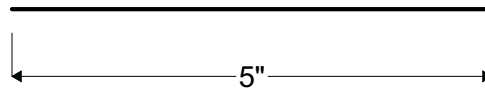

B1 Profile Flat Width Required
Scale: 6" = 1'-0"

TRIM 05E PROPERTY OF IBEX NOT FOR REPRODUCTION WITHOUT PRIOR WRITTEN CONSENT OF IBEX METAL, LLC	TRIM 05E

Product ID :	05E
Name :	J-CHANNEL (1" RIB)
Description :	Wide J-Channel For 1" Panel Ribs



Metal Roofing, Siding, and Trim
 P: 208-565-3002
 www.ibexmetal.com
 info@ibexmetal.com
 280 Great Northern Road
 Bonners Ferry, ID 83805

TRIM 05E

1

2

3

FRACTIONS ROUNDED TO NEAREST 1/16"
REVISED: 12/12/23

29 | 26

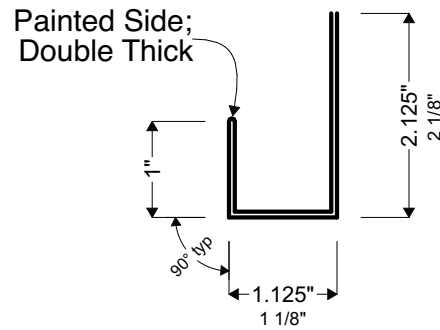

ARCHITECTURAL SERIES

A1 Profile Section Detail
Scale: 6" = 1'-0"



B1 Profile Flat Width Required
Scale: 6" = 1'-0"

TRIM 05F PROPERTY OF IBEX NOT FOR REPRODUCTION WITHOUT PRIOR WRITTEN PERMISSION OF IBEX METAL, LLC	TRIM 05F

<i>Product ID :</i>	05F
<i>Name :</i>	FULL WRAP J-CHANNEL (1" RIB)
<i>Description :</i>	Wide 2-Sided J-Channel For 1" Panel Ribs



Metal Roofing, Siding, and Trim
 P: 208-565-3002
 www.ibexmetal.com
 info@ibexmetal.com
 280 Great Northern Road
 Bonners Ferry, ID 83805

1

2

3

FRACTIONS ROUNDED TO NEAREST 1/16"
REVISED: 12/12/23

29 | 26

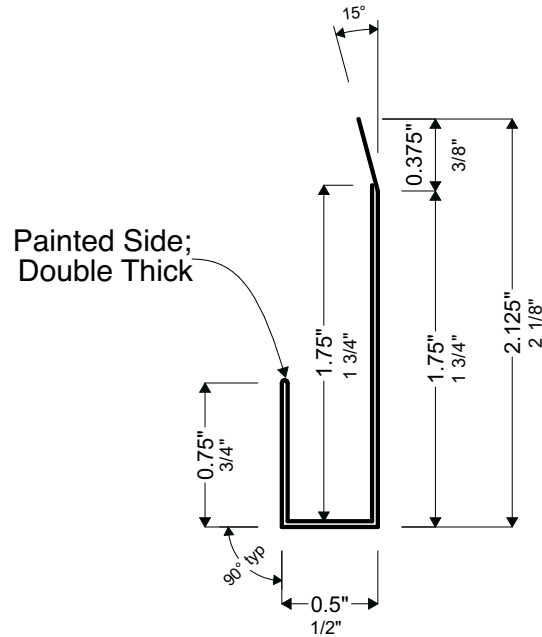

ARCHITECTURAL SERIES

A1 Profile Section Detail
Scale: 1' = 1'-0"

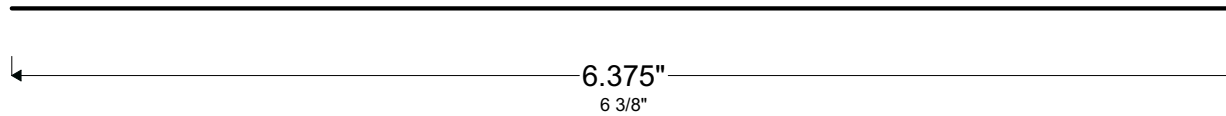

B1 Profile Flat Width Required
Scale: 1' = 1'-0"

TRIM 05G PROPERTY OF IBEX NOT FOR REPRODUCTION WITHOUT PRIOR WRITTEN PERMISSION OF IBEX METAL, LLC	TRIM 05G

Product ID :	05G
Name :	FULL WRAP MINI J-CHANNEL
Description :	Small 2-Sided J-Channel Typically Used w/Soffit



Metal Roofing, Siding, and Trim
 P: 208-565-3002
 www.ibexmetal.com
 info@ibexmetal.com
 280 Great Northern Road
 Bonners Ferry, ID 83805

1

2

3

FRACTIONS ROUNDED TO NEAREST 1/16"
REVISED: *Work in Progress*

29 | 26 | 24 | 22

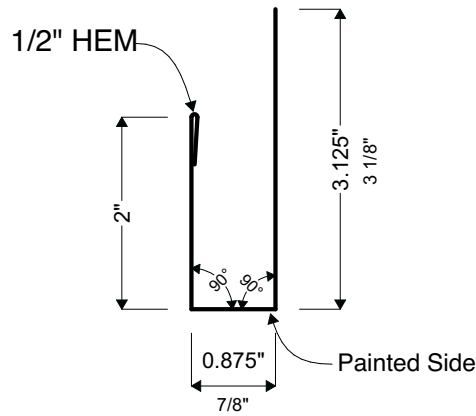

A **A1** Profile Section Detail
Scale: 6" = 1'-0"

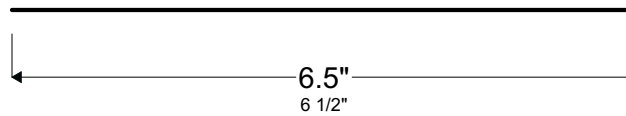

B **B1** Profile Flat Width Required
Scale: 6" = 1'-0"

TRIM 05J

PROPERTY OF IBEX
NOT FOR REPRODUCTION WITHOUT PRIOR
WRITTEN CONSENT OF IBEX METAL, LLC

<i>Product ID :</i>	05J
<i>Name :</i>	J-CHANNEL (2" FACE)
<i>Description :</i>	J-Channel With 2" Exposed Face

IDAHO'S BEST EXTERIORS

Metal Roofing, Siding, and Trim
 P: 208-565-3002
 www.ibexmetal.com
 info@ibexmetal.com
 280 Great Northern Road
 Bonners Ferry, ID 83805

1

2

3

FRACTIONS ROUNDED TO NEAREST 1/16"
REVISED: 4/5/23

29 | 26 | 24 | 22

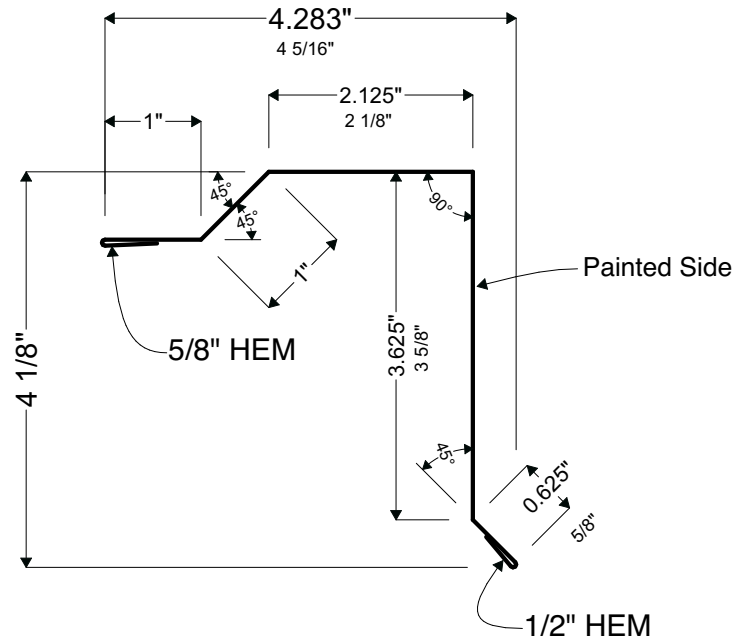

A1 Profile Section Detail
Scale: 6" = 1'-0"

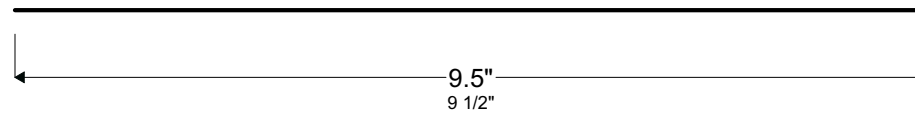

B1 Profile Flat Width Required
Scale: 6" = 1'-0"

TRIM 06 PROPERTY OF IBEX NOT FOR REPRODUCTION WITHOUT PRIOR WRITTEN CONSENT OF IBEX METAL, LLC	TRIM 06

Product ID :	06
Name :	MINI GABLE
Description :	Gable End Flashing (Matches MINI EAVE)



Metal Roofing, Siding, and Trim
 P: 208-565-3002
 www.ibexmetal.com
 info@ibexmetal.com
 280 Great Northern Road
 Bonners Ferry, ID 83805

1

2

3

FRACTIONS ROUNDED TO NEAREST 1/16"
REVISED: 4/5/23

29 | 26 | 24 | 22

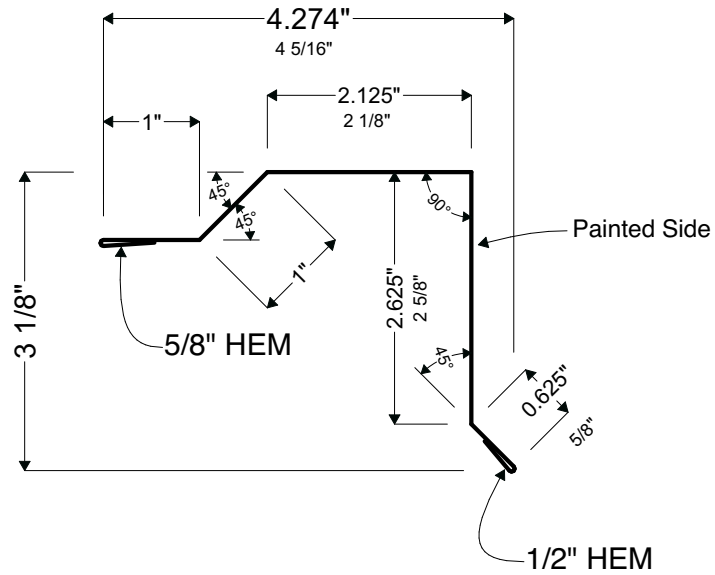

A1 Profile Section Detail
Scale: 6" = 1'-0"

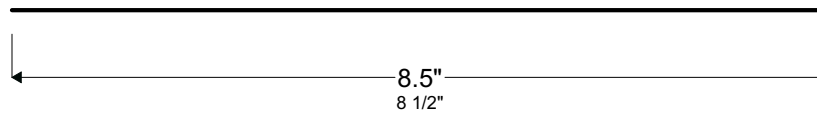

B1 Profile Flat Width Required
Scale: 6" = 1'-0"

TRIM 06B PROPERTY OF IBEX NOT FOR REPRODUCTION WITHOUT PRIOR WRITTEN CONSENT OF IBEX METAL, LLC	TRIM 06B

Product ID :	06B
Name :	MINI MINI GABLE
Description :	When MINI isn't mini enough



Metal Roofing, Siding, and Trim
 P: 208-565-3002
 www.ibexmetal.com
 info@ibexmetal.com
 280 Great Northern Road
 Bonners Ferry, ID 83805

TRIM 06B

1

2

3

FRACTIONS ROUNDED TO NEAREST 1/16"
REVISED: 4/5/23

29 | 26 | 24 | 22

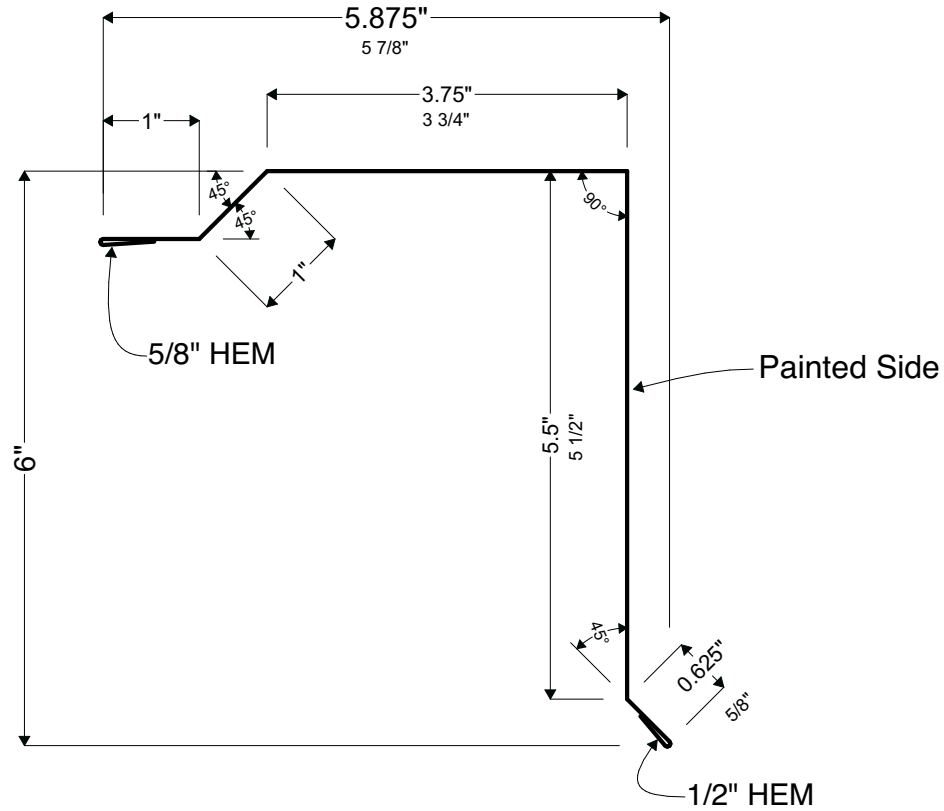

A1 Profile Section Detail
Scale: 6" = 1'-0"

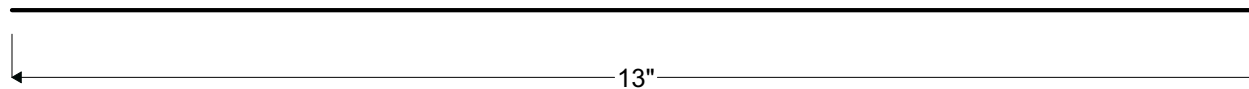

B1 Profile Flat Width Required
Scale: 6" = 1'-0"

TRIM 06C PROPERTY OF IBEX NOT FOR REPRODUCTION WITHOUT PRIOR WRITTEN CONSENT OF IBEX METAL, LLC	TRIM 06C

Product ID :	06C
Name :	OVERSIZED GABLE
Description :	Large Gable Flashing Trim



Metal Roofing, Siding, and Trim
 P: 208-565-3002
 www.ibexmetal.com
 info@ibexmetal.com
 280 Great Northern Road
 Bonners Ferry, ID 83805

TRIM 06C

1

2

3

FRACTIONS ROUNDED TO NEAREST 1/16"
REVISED: 4/18/23

29 | 26 | 24 | 22

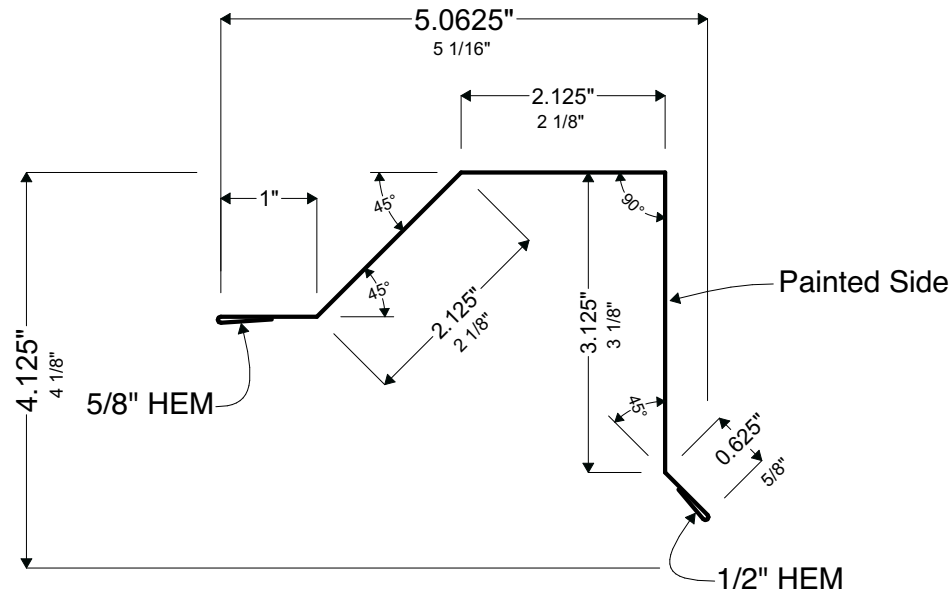

A1 Profile Section Detail
Scale: 6" = 1'-0"

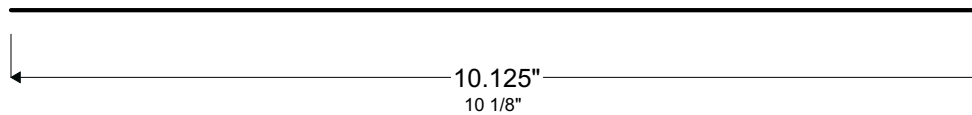

B1 Profile Flat Width Required
Scale: 6" = 1'-0"

TRIM 06D PROPERTY OF IBEX NOT FOR REPRODUCTION WITHOUT PRIOR WRITTEN CONSENT OF IBEX METAL, LLC	TRIM 06D

Product ID :	06D
Name :	STANDING SEAM GABLE (1.5" RIB)
Description :	Gable Trim for 1 1/2" Standing Seam Profiles



Metal Roofing, Siding, and Trim
 P: 208-565-3002
 www.ibexmetal.com
 info@ibexmetal.com
 280 Great Northern Road
 Bonners Ferry, ID 83805

TRIM 06D

1

2

3

FRACTIONS ROUNDED TO NEAREST 1/16"
REVISED: 4/18/23

29 | 26 | 24 | 22

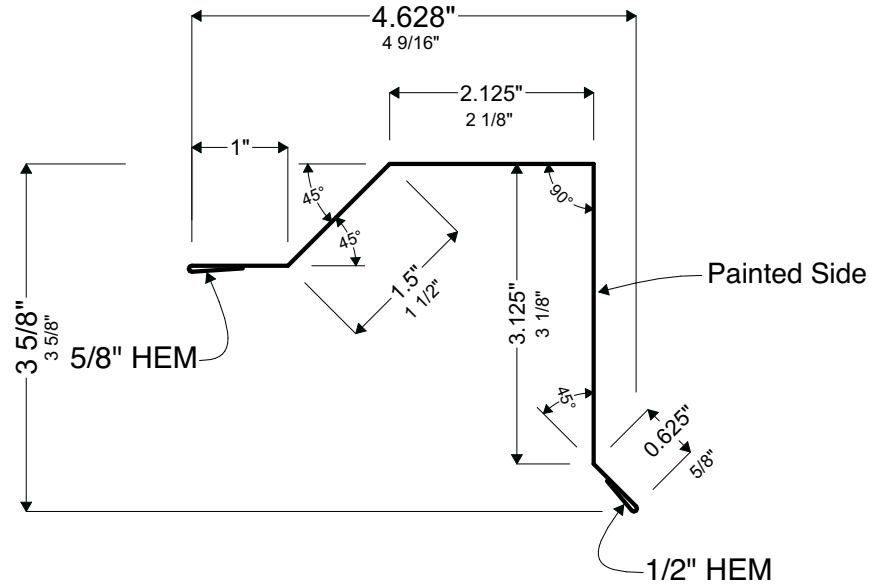

A1 Profile Section Detail
Scale: 6" = 1'-0"

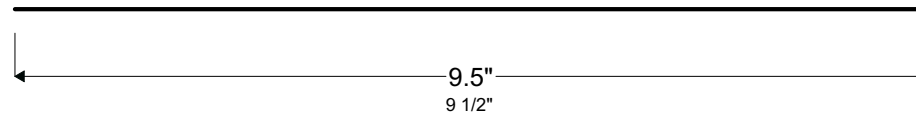

B1 Profile Flat Width Required
Scale: 6" = 1'-0"

TRIM 06E
 PROPERTY OF IBEX
 NOT FOR REPRODUCTION WITHOUT PRIOR
 WRITTEN PERMISSION OF IBEX METAL, LLC
 TRIM 06E

Product ID :	06E
Name :	STANDING SEAM GABLE (1" RIB)
Description :	Gable Trim for 1" Standing Seam Profiles



IBEX

IDAHO'S BEST EXTERIORS

Metal Roofing, Siding, and Trim

P: 208-565-3002
www.ibexmetal.com
info@ibexmetal.com

280 Great Northern Road
 Bonners Ferry, ID 83805

1

2

3

FRACTIONS ROUNDED TO NEAREST 1/16"
REVISED: 4/5/23

29 | 26 | 24 | 22

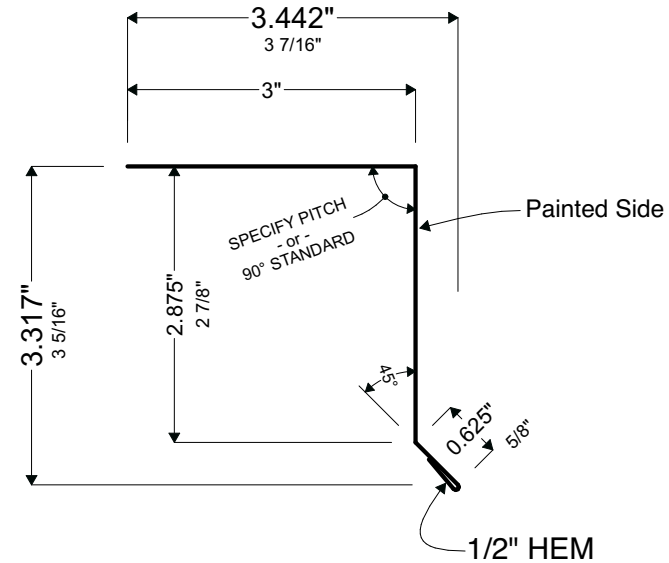
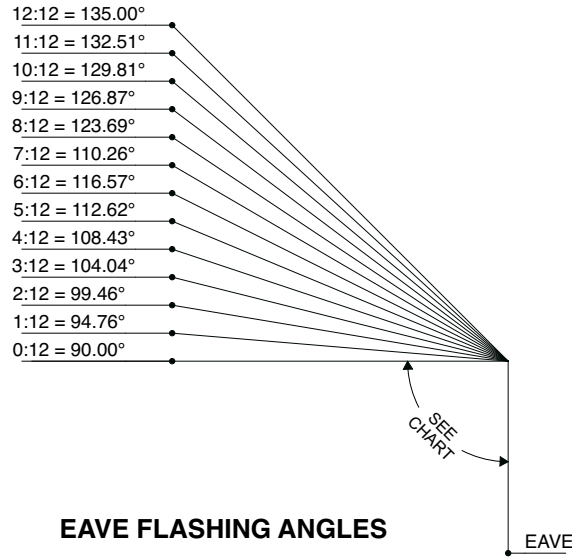

A1 Profile Section Detail
Scale: 6" = 1'-0"

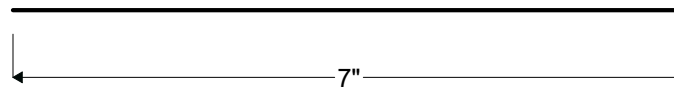

B1 Profile Flat Width Required
Scale: 6" = 1'-0"

TRIM 07
PROPERTY OF IBEX NOT FOR REPRODUCTION WITHOUT PRIOR WRITTEN CONSENT OF IBEX METAL, LLC
TRIM 07

Product ID :	07
Name :	MINI EAVE
Description :	Eave Trim (Matches MINI GABLE)



Metal Roofing, Siding, and Trim

P: 208-565-3002
www.ibexmetal.com
info@ibexmetal.com

280 Great Northern Road
Bonners Ferry, ID 83805

FRACTIONS ROUNDED TO NEAREST 1/16"
 REVISED: 12/12/23

29 | 26 | 24 | 22

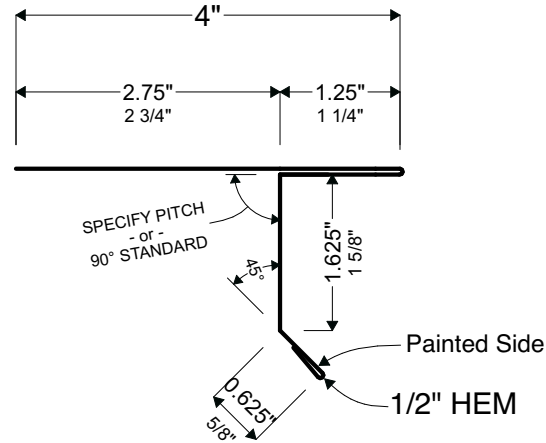

ARCHITECTURAL SERIES

A1 Profile Section Detail
 Scale: 6" = 1'-0"

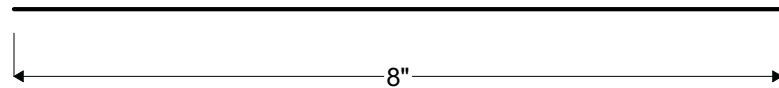

B1 Profile Flat Width Required
 Scale: 6" = 1'-0"

TRIM 07B

PROPERTY OF IBEX
 NOT FOR REPRODUCTION WITHOUT PRIOR
 WRITTEN CONSENT OF IBEX METAL, LLC

<i>Product ID :</i>	07B
<i>Name :</i>	STANDING SEAM EAVE (D DRIP EDGE)
<i>Description :</i>	Eave Trim (Matches Standing Seam Gable)

IBEX

IDAHO'S BEST EXTERIORS

Metal Roofing, Siding, and Trim
 P: 208-565-3002
 www.ibexmetal.com
 info@ibexmetal.com
 280 Great Northern Road
 Bonners Ferry, ID 83805

FRACTIONS ROUNDED TO NEAREST 1/16"
 REVISED: 12/12/23

29 | 26 | 24 | 22

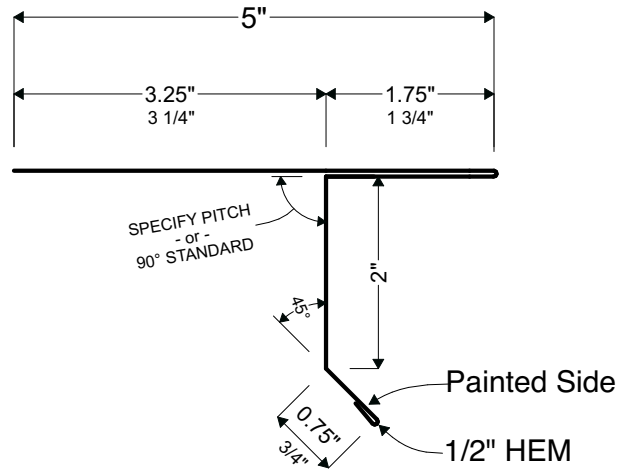

ARCHITECTURAL SERIES

A1 Profile Section Detail
 Scale: 6" = 1'-0"

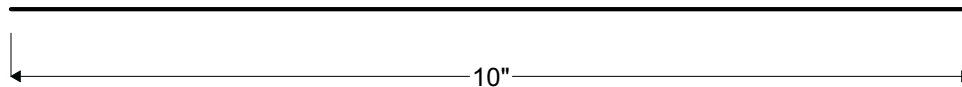

B1 Profile Flat Width Required
 Scale: 6" = 1'-0"

TRIM 07C
PROPERTY OF IBEX
 NOT FOR REPRODUCTION WITHOUT PRIOR
 WRITTEN CONSENT OF IBEX METAL, LLC
TRIM 07C

<i>Product ID :</i>	07C
<i>Name :</i>	JUMBO STANDING SEAM EAVE (D DRIP EDGE)
<i>Description :</i>	Large Eave Trim for Standing Seam



Metal Roofing, Siding, and Trim
 P: 208-565-3002
 www.ibexmetal.com
 info@ibexmetal.com
 280 Great Northern Road
 Bonners Ferry, ID 83805

FRACTIONS ROUNDED TO NEAREST 1/16"
 REVISED: 4/5/23

29 | 26 | 24 | 22

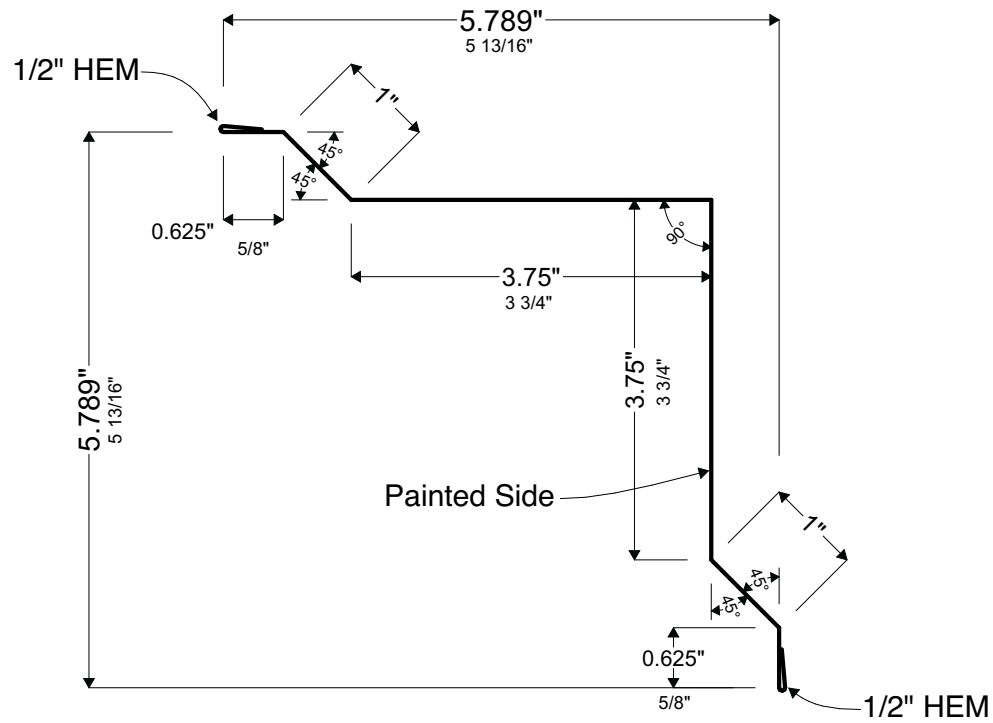

A1 Profile Section Detail
 Scale: 6" = 1'-0"

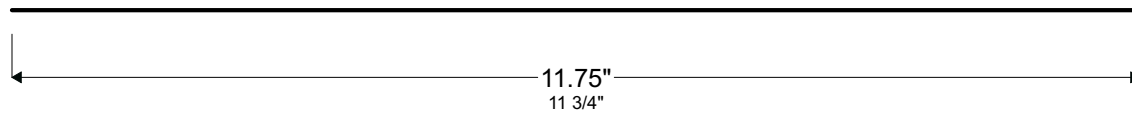

B1 Profile Flat Width Required
 Scale: 6" = 1'-0"

TRIM 08 PROPERTY OF IBEX NOT FOR REPRODUCTION WITHOUT PRIOR WRITTEN CONSENT OF IBEX METAL, LLC	TRIM 08

Product ID :	08
Name :	INSIDE CORNER
Description :	Inside Corner Trim



Metal Roofing, Siding, and Trim
 P: 208-565-3002
 www.ibexmetal.com
 info@ibexmetal.com
 280 Great Northern Road
 Bonners Ferry, ID 83805

FRACTIONS ROUNDED TO NEAREST 1/16"
 REVISED: 7/18/23

29 | 26 | 24 | 22

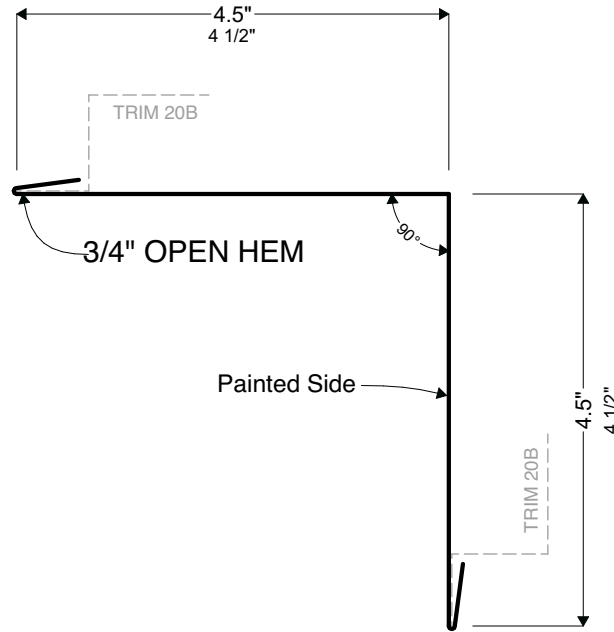

ARCHITECTURAL SERIES

A1 Profile Section Detail
 Scale: 6" = 1'-0"

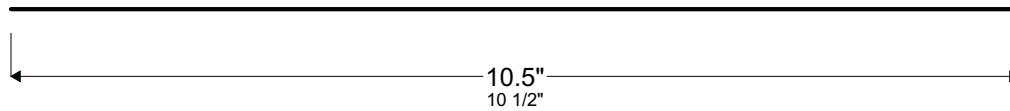

B1 Profile Flat Width Required
 Scale: 6" = 1'-0"

TRIM 08B PROPERTY OF IBEX NOT FOR REPRODUCTION WITHOUT PRIOR WRITTEN CONSENT OF IBEX METAL, LLC	TRIM 08B	Product ID : 08B
		Name : ARCHITECTURAL INSIDE CORNER
		Description : Concealed Fastener Inside Corner Trim



Metal Roofing, Siding, and Trim
 P: 208-565-3002
 www.ibexmetal.com
 info@ibexmetal.com
 280 Great Northern Road
 Bonners Ferry, ID 83805

FRACTIONS ROUNDED TO NEAREST 1/16"
 REVISED: 12/12/23

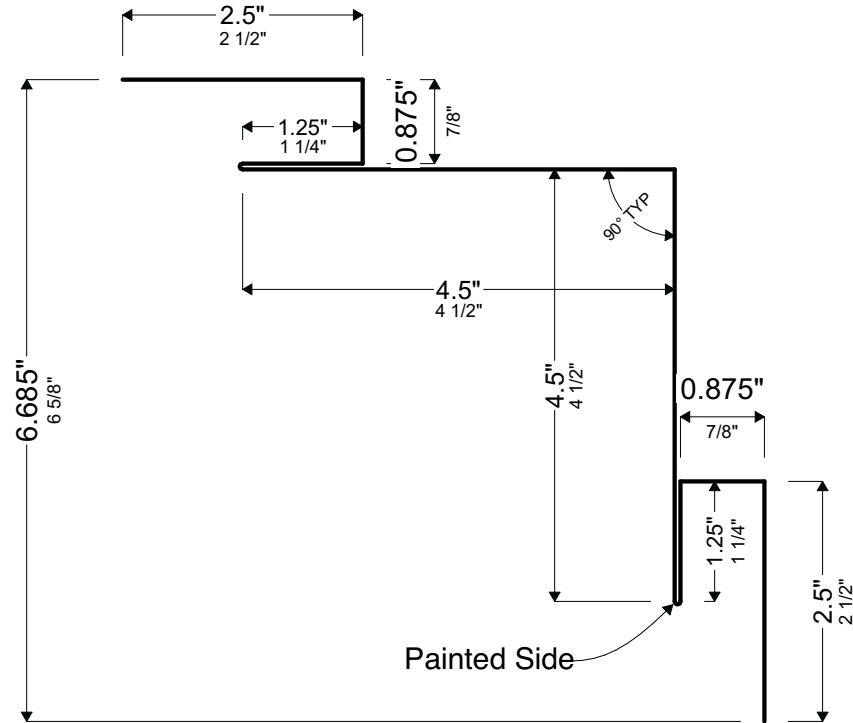

29 | 26 | 24

ARCHITECTURAL SERIES

A1 Profile Section Detail
 Scale: 6" = 1'-0"

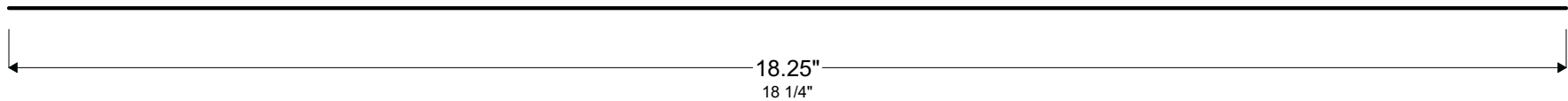

B1 Profile Flat Width Required
 Scale: 6" = 1'-0"

TRIM 08C PROPERTY OF IBEX NOT FOR REPRODUCTION WITHOUT PRIOR WRITTEN CONSENT OF IBEX METAL, LLC TRIM 08C	TRIM 08C
--	----------

Product ID :	08C
Name :	TRIM FIRST INSIDE CORNER
Description :	Siding Inside Corner Trim (Trim First)



Metal Roofing, Siding, and Trim
 P: 208-565-3002
 www.ibexmetal.com
 info@ibexmetal.com
 280 Great Northern Road
 Bonners Ferry, ID 83805

1

2

3

FRACTIONS ROUNDED TO NEAREST 1/16"
REVISED: *Work in Progress*

29 | 26 | 24

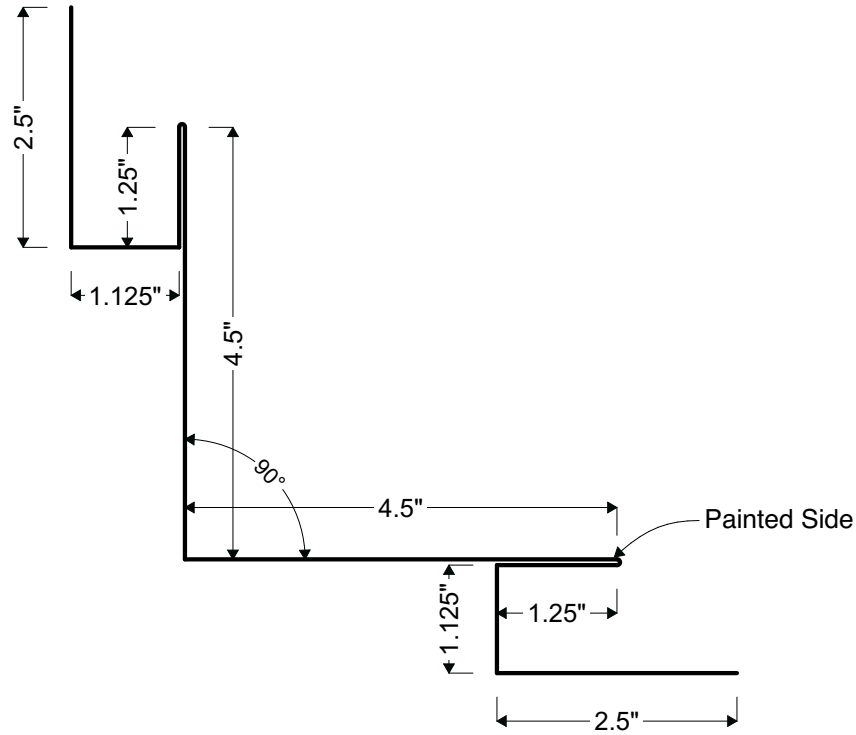

A1 Profile Section Detail
Scale: 6" = 1'-0"

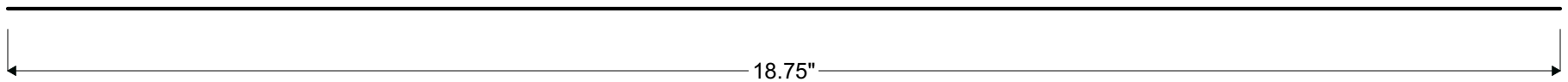

B1 Profile Flat Width Required
Scale: 6" = 1'-0"

TRIM 08D

<i>Product ID :</i>	08D
<i>Name :</i>	TRIM FIRST INSIDE CORNER (1" RIB)
<i>Description :</i>	Siding Inside Corner for 1" Ribs (Trim First)



Metal Roofing, Siding, and Trim
 P: 208-565-3002
 www.ibexmetal.com
 info@ibexmetal.com
 280 Great Northern Road
 Bonners Ferry, ID 83805

TRIM 08D

PROPERTY OF IBEX
NOT FOR REPRODUCTION WITHOUT PRIOR WRITTEN CONSENT OF IBEX METAL, LLC

1

2

3

FRACTIONS ROUNDED TO NEAREST 1/16"
REVISED: 4/5/23

29 | 26 | 24 | 22

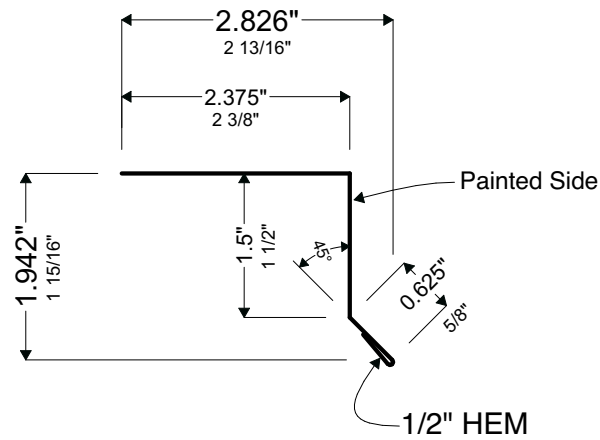

A **A1** Profile Section Detail
Scale: 6" = 1'-0"

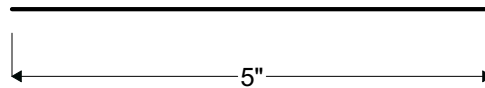

B **B1** Profile Flat Width Required
Scale: 6" = 1'-0"

TRIM 09 PROPERTY OF IBEX NOT FOR REPRODUCTION WITHOUT PRIOR WRITTEN CONSENT OF IBEX METAL, LLC	TRIM 09

Product ID :	09
Name :	DRIP EDGE
Description :	Drip Edge Flashing



Metal Roofing, Siding, and Trim
 P: 208-565-3002
 www.ibexmetal.com
 info@ibexmetal.com
 280 Great Northern Road
 Bonners Ferry, ID 83805

1

2

3

FRACTIONS ROUNDED TO NEAREST 1/16"
REVISED: 12/12/23

29 | 26 | 24 | 22

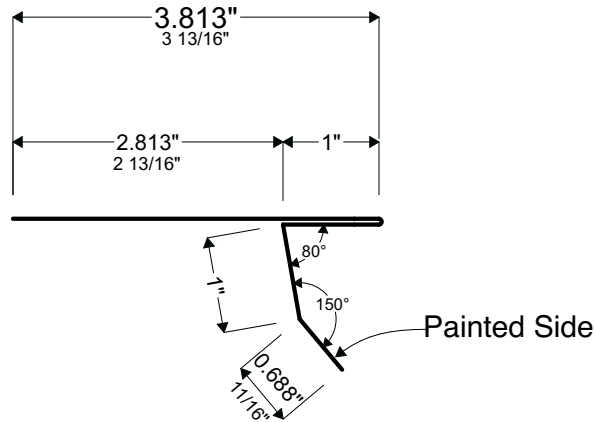

A **A1** Profile Section Detail
Scale: 6" = 1'-0"

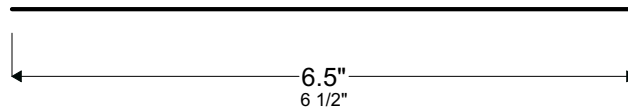

B **B1** Profile Flat Width Required
Scale: 6" = 1'-0"

TRIM 09B

PROPERTY OF IBEX
NOT FOR REPRODUCTION WITHOUT PRIOR
WRITTEN CONSENT OF IBEX METAL, LLC

TRIM 09B

<i>Product ID :</i>	09B
<i>Name :</i>	DRIP EDGE B
<i>Description :</i>	D-Style Drip Edge for Standing Seam Profiles



Metal Roofing, Siding, and Trim
 P: 208-565-3002
 www.ibexmetal.com
 info@ibexmetal.com
 280 Great Northern Road
 Bonners Ferry, ID 83805

1

2

3

FRACTIONS ROUNDED TO NEAREST 1/16"
REVISED: 7/18/23

29 | 26 | 24 | 22

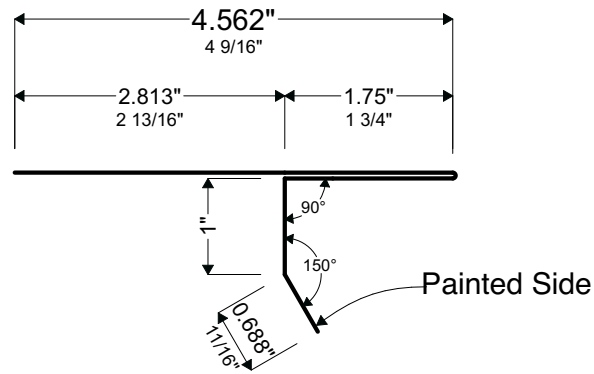

ARCHITECTURAL SERIES

A1 Profile Section Detail
Scale: 6" = 1'-0"

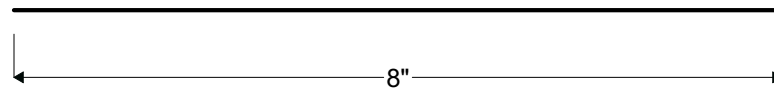

B1 Profile Flat Width Required
Scale: 6" = 1'-0"

TRIM 09C

PROPERTY OF IBEX
NOT FOR REPRODUCTION WITHOUT PRIOR
WRITTEN PERMISSION OF IBEX METAL, LLC

TRIM 09C

<i>Product ID :</i>	09C
<i>Name :</i>	DRIP EDGE C
<i>Description :</i>	D-Style Drip Edge for Standing Seam Profiles



Metal Roofing, Siding, and Trim
 P: 208-565-3002
 www.ibexmetal.com
 info@ibexmetal.com
 280 Great Northern Road
 Bonners Ferry, ID 83805

1

2

3

FRACTIONS ROUNDED TO NEAREST 1/16"
REVISED: 12/12/23

29 | 26 | 24 | 22

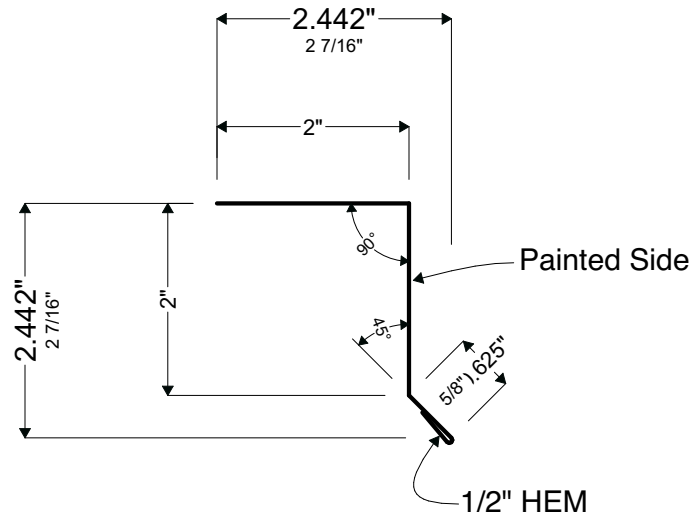

A

A1 Profile Section Detail
Scale: 6" = 1'-0"

A

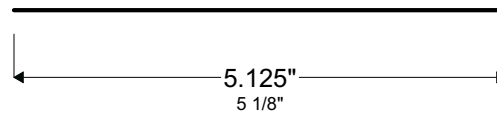

B

B1 Profile Flat Width Required
Scale: 6" = 1'-0"

B

TRIM 09D

PROPERTY OF IBEX
NOT FOR REPRODUCTION WITHOUT PRIOR
WRITTEN CONSENT OF IBEX METAL, LLC

TRIM 09D

<i>Product ID :</i>	09D
<i>Name :</i>	2x2 DRIP EDGE
<i>Description :</i>	Drip Edge Flashing



Metal Roofing, Siding, and Trim
 P: 208-565-3002
 www.ibexmetal.com
 info@ibexmetal.com
 280 Great Northern Road
 Bonners Ferry, ID 83805

FRACTIONS ROUNDED TO NEAREST 1/16"
 REVISED: 12/12/23

29 | 26 | 24 | 22

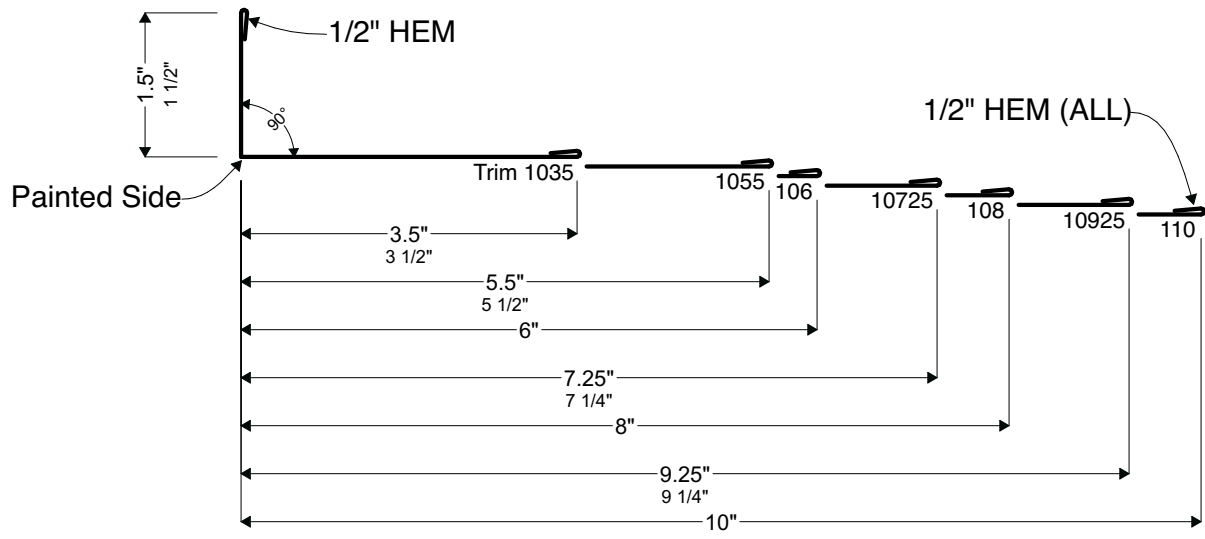

A1 Profile Section Detail
 Scale: 6" = 1'-0"

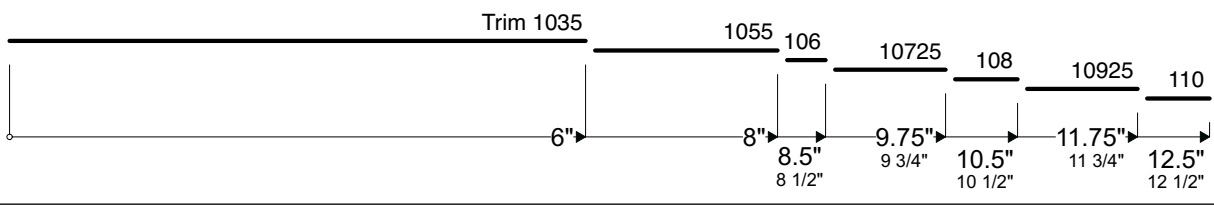

B1 Profile Flat Width Required
 Scale: 6" = 1'-0"

TRIM 10 PROPERTY OF IBEX NOT FOR REPRODUCTION WITHOUT PRIOR WRITTEN CONSENT OF IBEX METAL, LLC	TRIM 10
---	----------------

Product ID :	1035 - 1010
Name :	POST TRIM
Description :	Trim Covering Vertical Framing Posts



Metal Roofing, Siding, and Trim

P: 208-565-3002
 www.ibexmetal.com
 info@ibexmetal.com

280 Great Northern Road
 Bonners Ferry, ID 83805

IDAHO'S BEST EXTERIORS

FRACTIONS ROUNDED TO NEAREST 1/16"
 REVISED: 12/12/23

29 | 26 | 24 | 22

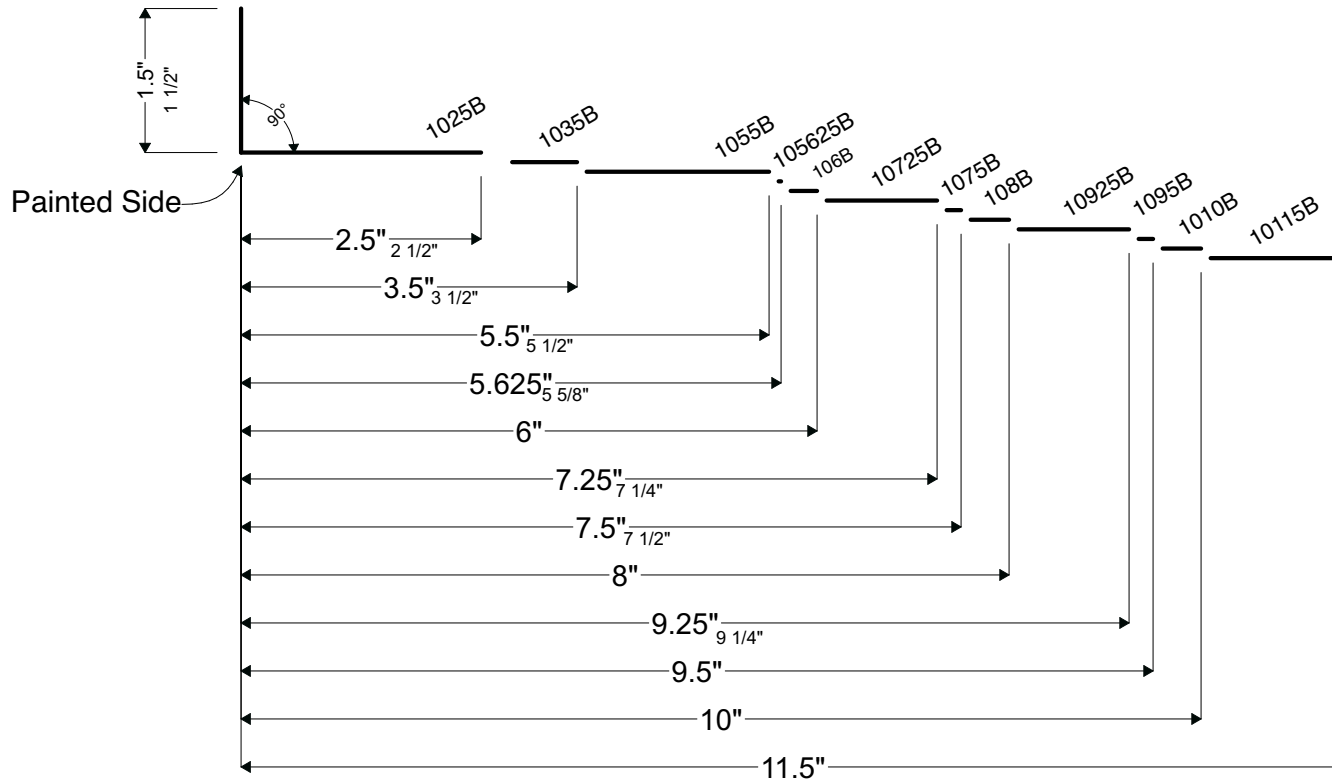

A1 Profile Section Detail
 Scale: 6" = 1'-0"

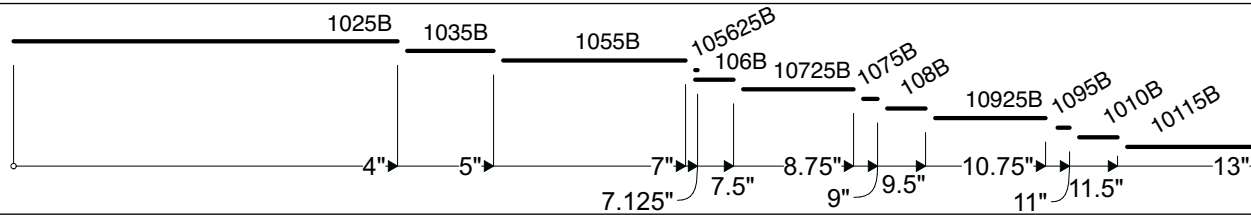

B1 Profile Flat Width Required
 Scale: 6" = 1'-0"

TRIM 10B

PROPERTY OF IBEX
 NOT FOR REPRODUCTION WITHOUT PRIOR
 WRITTEN CONSENT OF IBEX METAL, LLC

TRIM 10B

Product ID :	1035B - 1010B
Name :	POST TRIM B
Description :	Trim Covering Vertical Framing Posts (NO HEM)



Metal Roofing, Siding, and Trim
 P: 208-565-3002
 www.ibexmetal.com
 info@ibexmetal.com
 280 Great Northern Road
 Bonners Ferry, ID 83805

1

2

3

FRACTIONS ROUNDED TO NEAREST 1/16"
REVISED: 12/12/23

FOLDED: 29 | 26 | 24 | 22

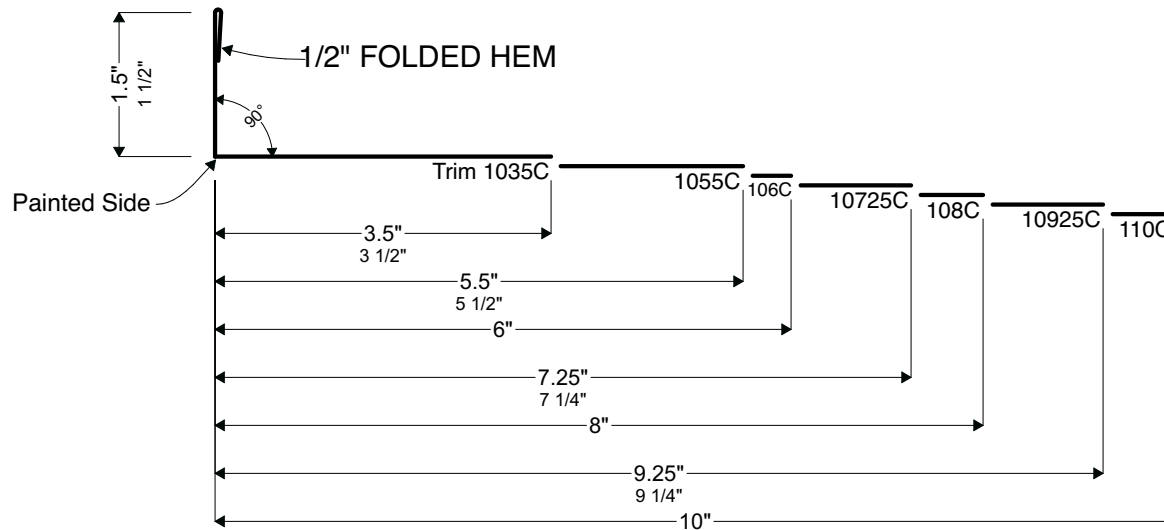

A1 Profile Section Detail
Scale: 6" = 1'-0"

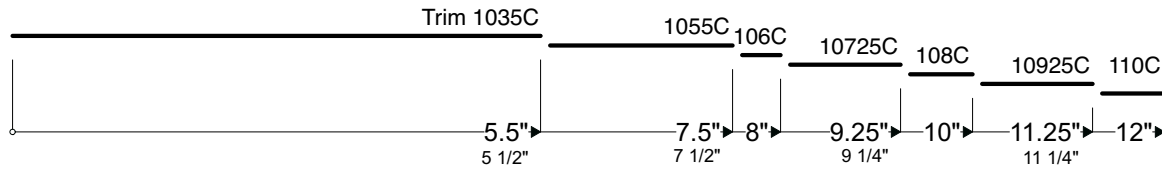

B1 Profile Flat Width Required
Scale: 6" = 1'-0"

TRIM 10C PROPERTY OF IBEX NOT FOR REPRODUCTION WITHOUT PRIOR WRITTEN PERMISSION OF IBEX METAL, LLC	TRIM 10C

Product ID :	1035C - 1010C
Name :	PLAIN FASCIA
Description :	Fascia Trim



Metal Roofing, Siding, and Trim
 P: 208-565-3002
 www.ibexmetal.com
 info@ibexmetal.com
 280 Great Northern Road
 Bonners Ferry, ID 83805

FRACTIONS ROUNDED TO NEAREST 1/16"
 REVISED: 12/15/23

29 | 26

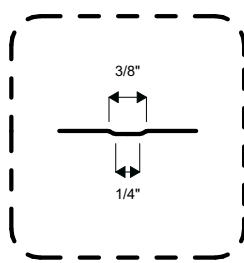
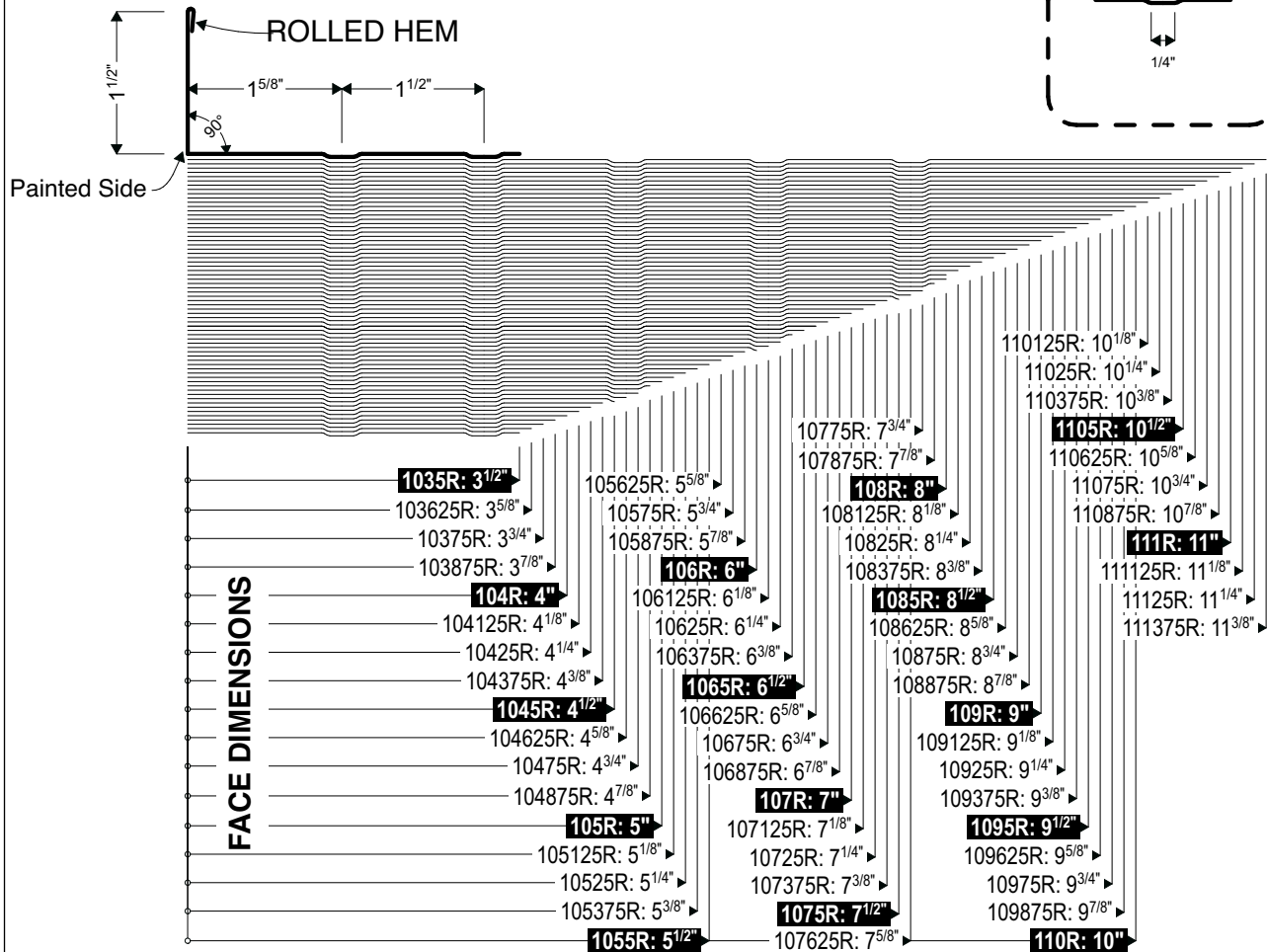

BLANK DIMENSIONS:
 FACE DIMENSION + 1.875" (17/8")

1035R: 5.375" (5.375")	107625R: 9.5" (9.5")
103625R: 5.5" (5.5")	10775R: 9.625" (9.625")
10375R: 5.625" (5.625")	107875R: 9.75" (9.75")
103875R: 5.75" (5.75")	108R: 9.875" (9.875")
104R: 5.875" (5.875")	108125R: 10" (10")
104125R: 6" (6")	10825R: 10.125" (10.125")
10425R: 6.125" (6.125")	108375R: 10.25" (10.25")
104375R: 6.25" (6.25")	1085R: 10.375" (10.375")
1045R: 6.375" (6.375")	108625R: 10.5" (10.5")
104625R: 6.5" (6.5")	10875R: 10.625" (10.625")
10475R: 6.625" (6.625")	108875R: 10.75" (10.75")
104875R: 6.75" (6.75")	109R: 10.875" (10.875")
105R: 6.875" (6.875")	109125R: 11" (11")
105125R: 7" (7")	10925R: 11.125" (11.125")
10525R: 7.125" (7.125")	109375R: 11.25" (11.25")
105375R: 7.25" (7.25")	1095R: 11.375" (11.375")
1055R: 7.375" (7.375")	109625R: 11.5" (11.5")
105625R: 7.5" (7.5")	10975R: 11.625" (11.625")
10575R: 7.625" (7.625")	109875R: 11.75" (11.75")
105875R: 7.75" (7.75")	110R: 11.875" (11.875")
106R: 7.875" (7.875")	110125R: 12" (12")
106125R: 8" (8")	11025R: 12.125" (12.125")
10625R: 8.125" (8.125")	110375R: 12.25" (12.25")
106375R: 8.25" (8.25")	1105R: 12.375" (12.375")
1065R: 8.375" (8.375")	110625R: 12.5" (12.5")
106625R: 8.5" (8.5")	11075R: 12.625" (12.625")
10675R: 8.625" (8.625")	110875R: 12.75" (12.75")
106875R: 8.75" (8.75")	111R: 12.875" (12.875")
107R: 8.875" (8.875")	111125R: 13" (13")
107125R: 9" (9")	11125R: 13.125" (13.125")
10725R: 9.125" (9.125")	111375R: 13.25" (13.25")
107375R: 9.25" (9.25")	1115R: 13.375" (13.375")
1075R: 9.375" (9.375")	

A1 Profile Section Detail
 Scale: 6" = 1'-0"

TRIM 10R PROPERTY OF IBEX NOT FOR REPRODUCTION WITHOUT PRIOR WRITTEN CONSENT OF IBEX METAL, LLC	TRIM 10R
	Product ID : 1035R - 10115R
	Name : RIBBED FASCIA

Description :	Rolled Fascia Trim (Ribbed)
---------------	-----------------------------



Metal Roofing, Siding, and Trim
 P: 208-565-3002
 www.ibexmetal.com
 info@ibexmetal.com
 280 Great Northern Road
 Bonners Ferry, ID 83805

1

2

3

FRACTIONS ROUNDED TO NEAREST 1/16"
REVISED: 12/12/23

29 | 26 | 24 | 22

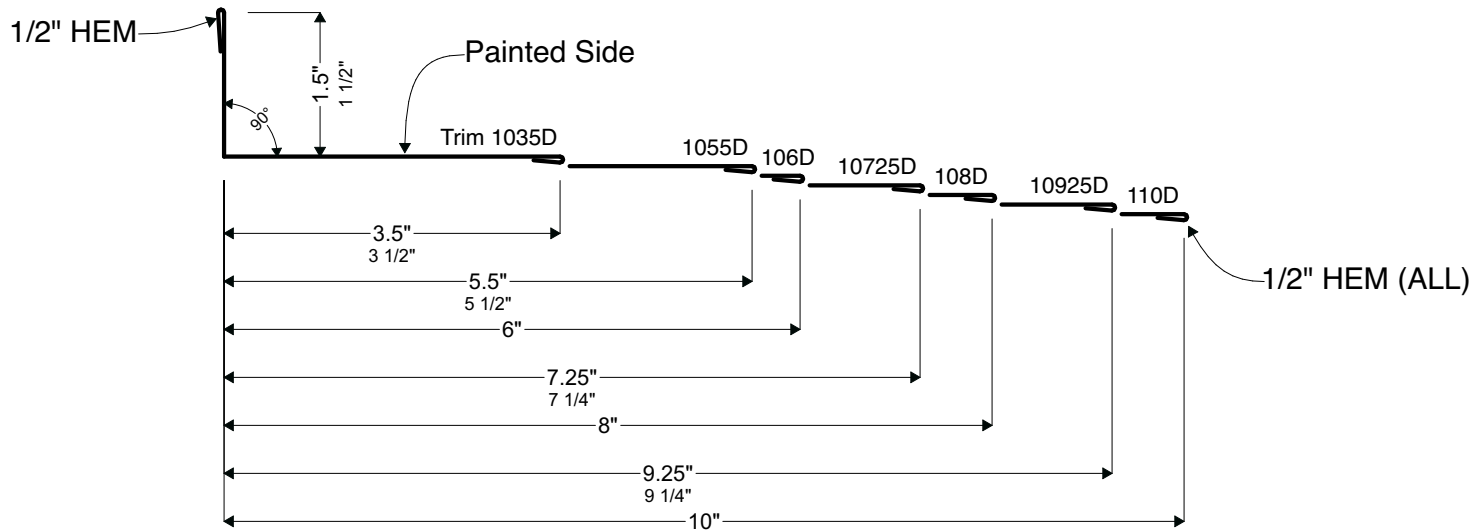

A1 Profile Section Detail
Scale: 6" = 1'-0"

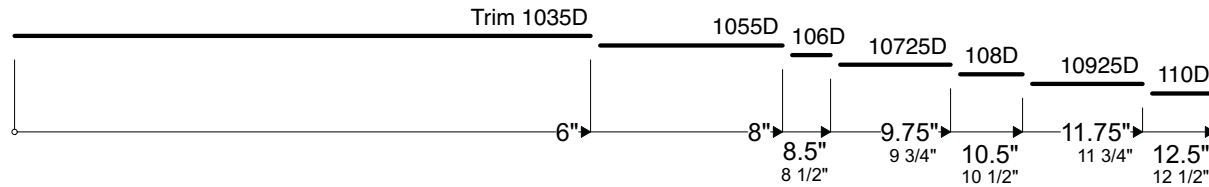

B1 Profile Flat Width Required
Scale: 6" = 1'-0"

TRIM 10D PROPERTY OF IBEX NOT FOR REPRODUCTION WITHOUT PRIOR WRITTEN CONSENT OF IBEX METAL, LLC	TRIM 10D

Product ID :	1035D - 1010D
Name :	INSIDE ANGLE
Description :	Multi-Use Inside Corner Angle



Metal Roofing, Siding, and Trim
 P: 208-565-3002
 www.ibexmetal.com
 info@ibexmetal.com
 280 Great Northern Road
 Bonners Ferry, ID 83805

1

2

3

FRACTIONS ROUNDED TO NEAREST 1/16"
REVISED: *Work in Progress*

29 | 26 | 24 | 22

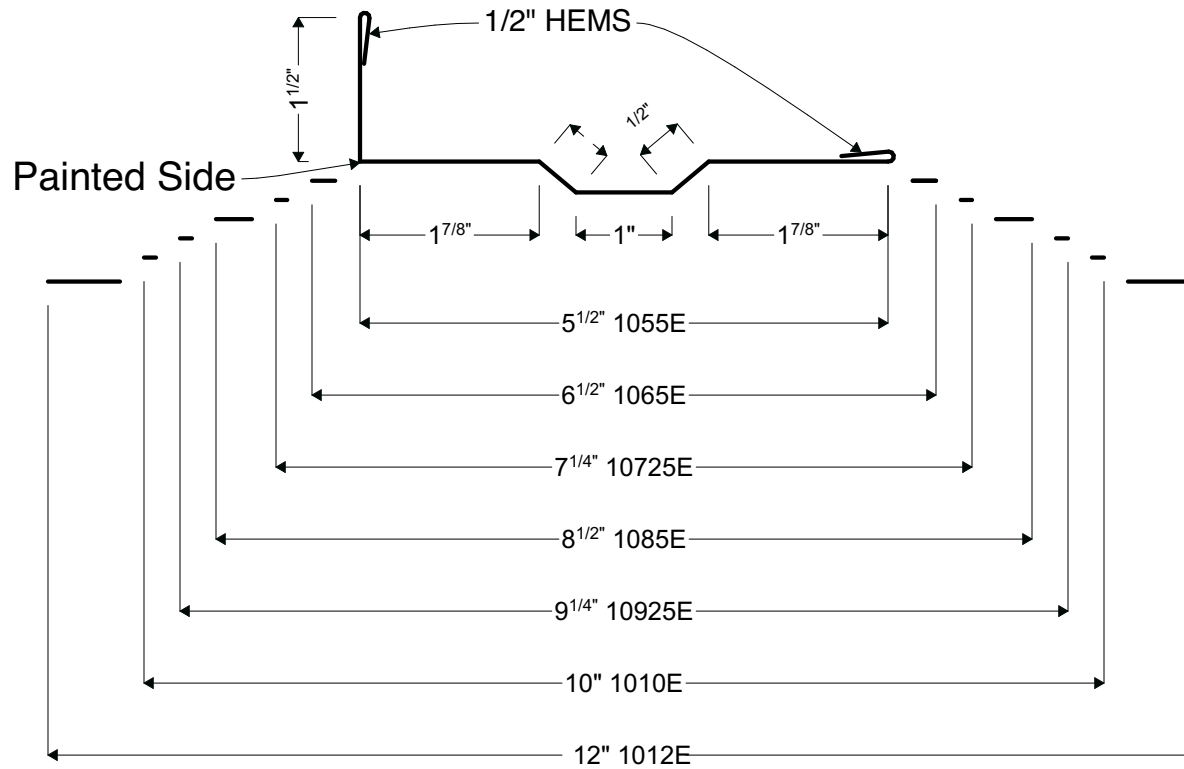

A1 Profile Section Detail
Scale: 6" = 1'-0"

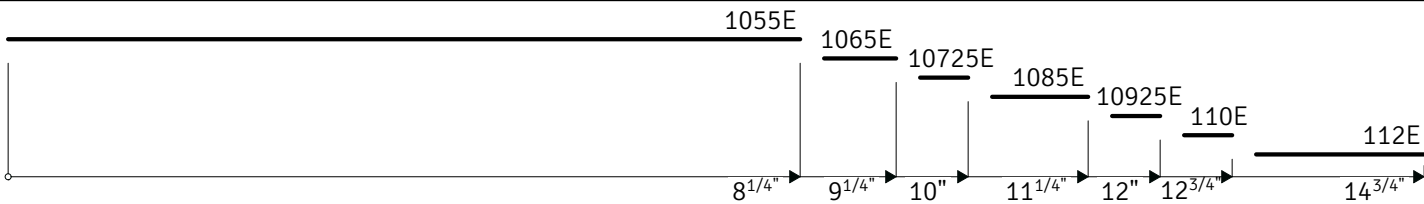

B1 Profile Flat Width Required
Scale: 6" = 1'-0"

TRIM 10E

PROPERTY OF IBEX
NOT FOR REPRODUCTION WITHOUT PRIOR
WRITTEN CONSENT OF IBEX METAL, LLC

<i>Product ID :</i>	1055E-112E
<i>Name :</i>	BIG RIB FASCIA
<i>Description :</i>	Fascia Trim with Large Rib



Metal Roofing, Siding, and Trim
 P: 208-565-3002
 www.ibexmetal.com
 info@ibexmetal.com
 280 Great Northern Road
 Bonners Ferry, ID 83805

1

2

3

FRACTIONS ROUNDED TO NEAREST 1/16"
REVISED: 12/12/23

29 | 26 | 24 | 22
LENGTH: 10'-4" ONLY

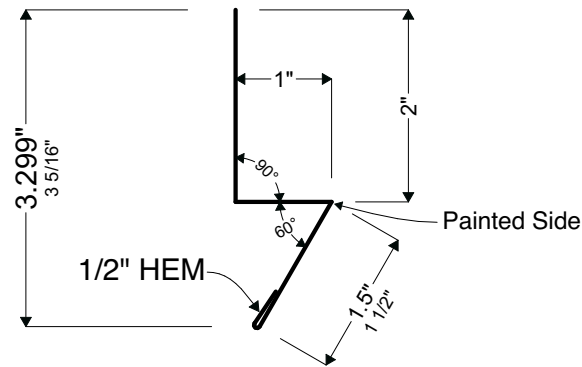

A

A1 Profile Section Detail
Scale: 6" = 1'-0"

A

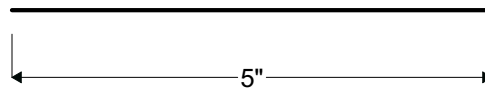

B

B1 Profile Flat Width Required
Scale: 6" = 1'-0"

B

TRIM 11 PROPERTY OF IBEX NOT FOR REPRODUCTION WITHOUT PRIOR WRITTEN CONSENT OF IBEX METAL, LLC	TRIM 11
---	----------------

<i>Product ID :</i>	11
<i>Name :</i>	RAT GUARD
<i>Description :</i>	Base Trim for Exterior Wall Panels



Metal Roofing, Siding, and Trim
 P: 208-565-3002
 www.ibexmetal.com
 info@ibexmetal.com
 280 Great Northern Road
 Bonners Ferry, ID 83805

1

2

3

FRACTIONS ROUNDED TO NEAREST 1/16"
REVISED: 12/12/23

29 | 26 | 24 | 22
LENGTH: 10'-4" ONLY

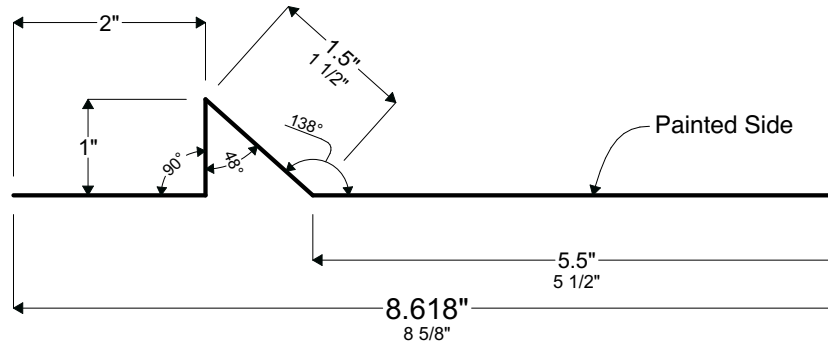

A1 Profile Section Detail
Scale: 6" = 1'-0"

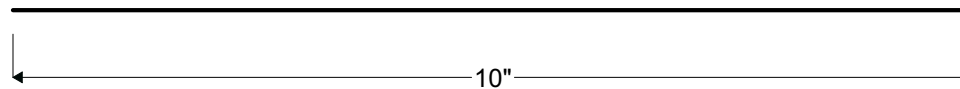

B1 Profile Flat Width Required
Scale: 6" = 1'-0"

TRIM 11B PROPERTY OF IBEX NOT FOR REPRODUCTION WITHOUT PRIOR WRITTEN CONSENT OF IBEX METAL, LLC	TRIM 11B

Product ID :	11B
Name :	FAT RAT
Description :	Extended Base Trim for Exterior Wall Panels



Metal Roofing, Siding, and Trim
 P: 208-565-3002
 www.ibexmetal.com
 info@ibexmetal.com
 280 Great Northern Road
 Bonners Ferry, ID 83805

1

2

3

FRACTIONS ROUNDED TO NEAREST 1/16"
REVISED: 12/12/23

29 | 26 | 24 | 22
LENGTH: 10'-4" ONLY

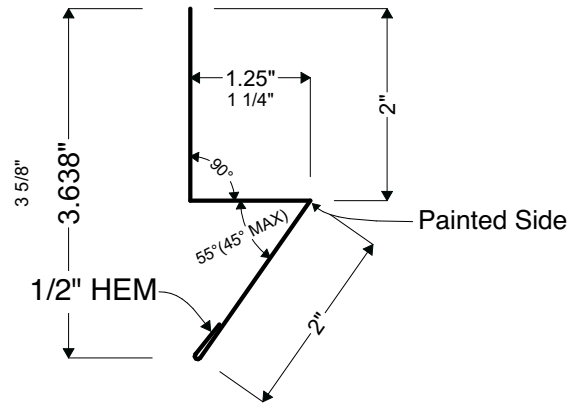

A1 Profile Section Detail
Scale: 6" = 1'-0"

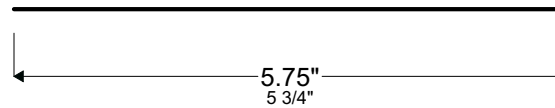

B1 Profile Flat Width Required
Scale: 6" = 1'-0"

PROPERTY OF IBEX
NOT FOR REPRODUCTION WITHOUT PRIOR
WRITTEN CONSENT OF IBEX METAL, LLC

TRIM 11C

<i>Product ID :</i>	11C
<i>Name :</i>	RAT GUARD (1" RIB)
<i>Description :</i>	Exterior Wall Base Trim for 1" Rib Panels



Metal Roofing, Siding, and Trim
 P: 208-565-3002
 www.ibexmetal.com
 info@ibexmetal.com
 280 Great Northern Road
 Bonners Ferry, ID 83805

1

2

3

FRACTIONS ROUNDED TO NEAREST 1/16"
REVISED: 4/5/23

29 | 26 | 24 | 22

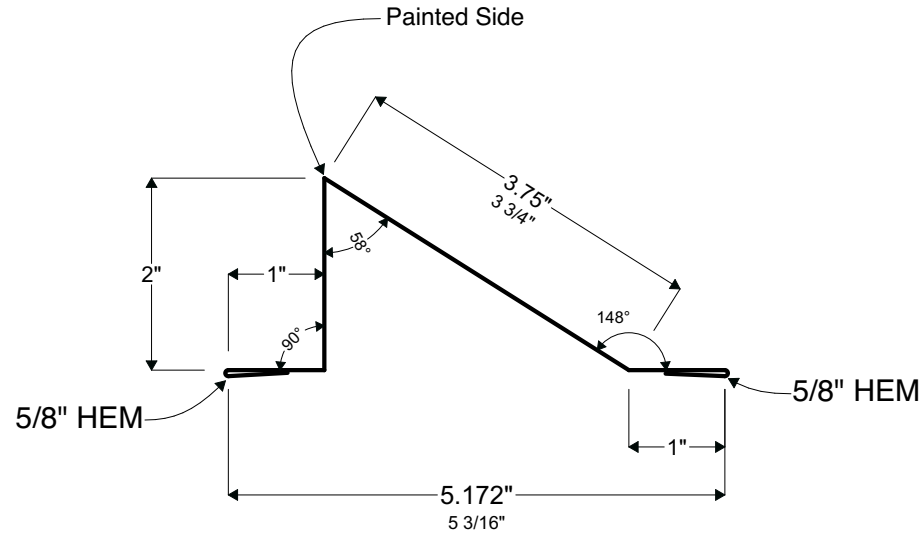

A1 Profile Section Detail
Scale: 6" = 1'-0"

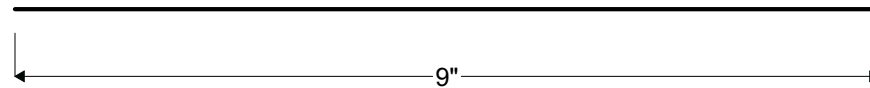

B1 Profile Flat Width Required
Scale: 6" = 1'-0"

TRIM 12

PROPERTY OF IBEX
NOT FOR REPRODUCTION WITHOUT PRIOR
WRITTEN CONSENT OF IBEX METAL, LLC

Product ID :	12
Name :	SNOW GUARD
Description :	Snow Guard for Roof



Metal Roofing, Siding, and Trim
 P: 208-565-3002
 www.ibexmetal.com
 info@ibexmetal.com
 280 Great Northern Road
 Bonners Ferry, ID 83805

1

2

3

FRACTIONS ROUNDED TO NEAREST 1/16"
REVISED: 12/12/23

29 | 26 | 24 | 22
LENGTH: 10'-4" ONLY

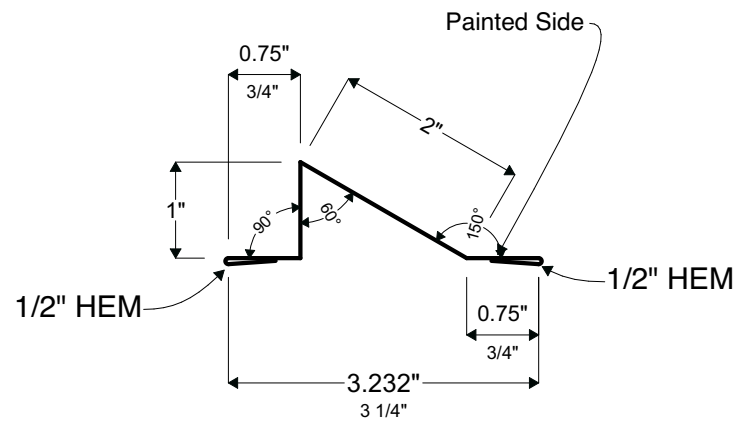

A **A1** Profile Section Detail
Scale: 6" = 1'-0"

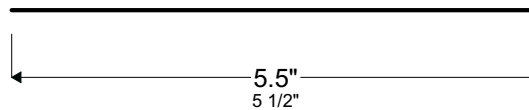

B **B1** Profile Flat Width Required
Scale: 6" = 1'-0"

TRIM 12B

PROPERTY OF IBEX
NOT FOR REPRODUCTION WITHOUT PRIOR
WRITTEN CONSENT OF IBEX METAL, LLC

<i>Product ID :</i>	12B
<i>Name :</i>	MINI SNOW GUARD
<i>Description :</i>	Mini Snow Guard for Roof



IBEX

IDAHO'S BEST EXTERIORS

Metal Roofing, Siding, and Trim

P: 208-565-3002
www.ibexmetal.com
info@ibexmetal.com

280 Great Northern Road
Bonners Ferry, ID 83805

1

2

3

FRACTIONS ROUNDED TO NEAREST 1/16"
REVISED: 12/12/23

29 | 26 | 24 | 22

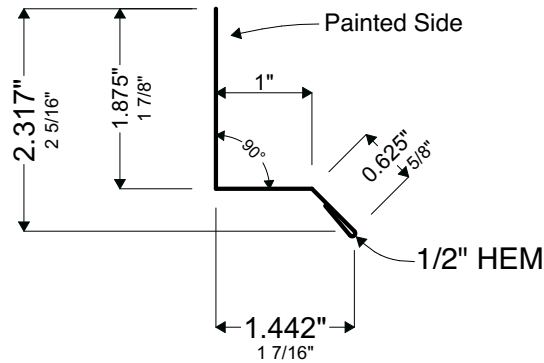

A1 Profile Section Detail
Scale: 6" = 1'-0"

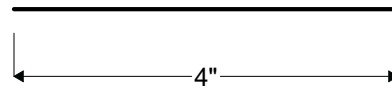

B1 Profile Flat Width Required
Scale: 6" = 1'-0"

TRIM 13

Product ID :	13
Name :	L BASE
Description :	Base Trim for Wall Panels



Metal Roofing, Siding, and Trim
 P: 208-565-3002
 www.ibexmetal.com
 info@ibexmetal.com
 280 Great Northern Road
 Bonners Ferry, ID 83805

PROPERTY OF IBEX
NOT FOR REPRODUCTION WITHOUT PRIOR
WRITTEN CONSENT OF IBEX METAL, LLC
TRIM 13

1

2

3

FRACTIONS ROUNDED TO NEAREST 1/16"
REVISED: 12/12/23

29 | 26 | 24 | 22

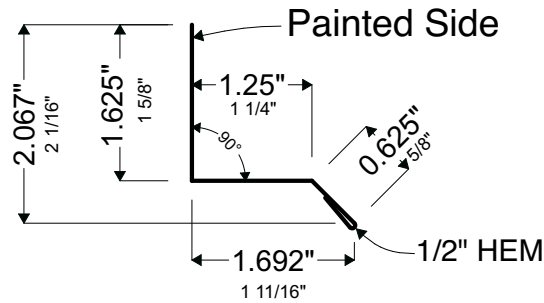

A1 Profile Section Detail
Scale: 6" = 1'-0"

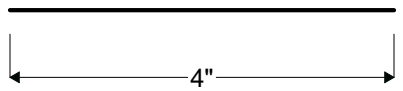

B1 Profile Flat Width Required
Scale: 6" = 1'-0"

TRIM 13B

PROPERTY OF IBEX
NOT FOR REPRODUCTION WITHOUT PRIOR
WRITTEN CONSENT OF IBEX METAL, LLC

<i>Product ID :</i>	13B
<i>Name :</i>	L BASE (1" RIB)
<i>Description :</i>	Exterior Wall Base Trim for 1" Rib Panels



IBEX

IDAHO'S BEST EXTERIORS

Metal Roofing, Siding, and Trim

P: 208-565-3002
www.ibexmetal.com
info@ibexmetal.com

280 Great Northern Road
Bonners Ferry, ID 83805

1

2

3

FRACTIONS ROUNDED TO NEAREST 1/16"
REVISED: 12/12/23

29 | 26

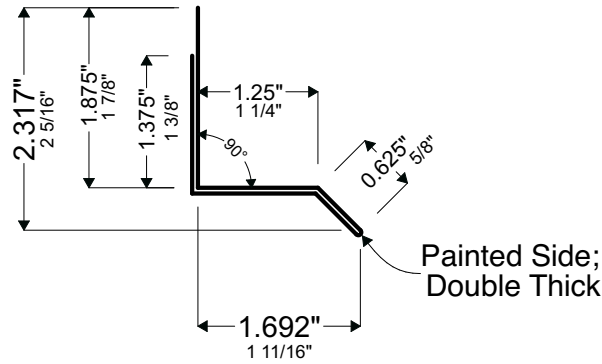

ARCHITECTURAL SERIES

A1 Profile Section Detail
Scale: 6" = 1'-0"

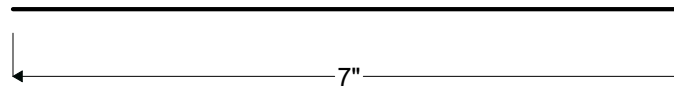

B1 Profile Flat Width Required
Scale: 6" = 1'-0"

TRIM 13C PROPERTY OF IBEX NOT FOR REPRODUCTION WITHOUT PRIOR WRITTEN CONSENT OF IBEX METAL, LLC	TRIM 13C

Product ID :	13C
Name :	FULL WRAP L BASE
Description :	Exterior Wall Base Trim w/Paint Inside



Metal Roofing, Siding, and Trim
 P: 208-565-3002
 www.ibexmetal.com
 info@ibexmetal.com
 280 Great Northern Road
 Bonners Ferry, ID 83805

1

2

3

FRACTIONS ROUNDED TO NEAREST 1/16"
REVISED: 7/18/23

29 | 26

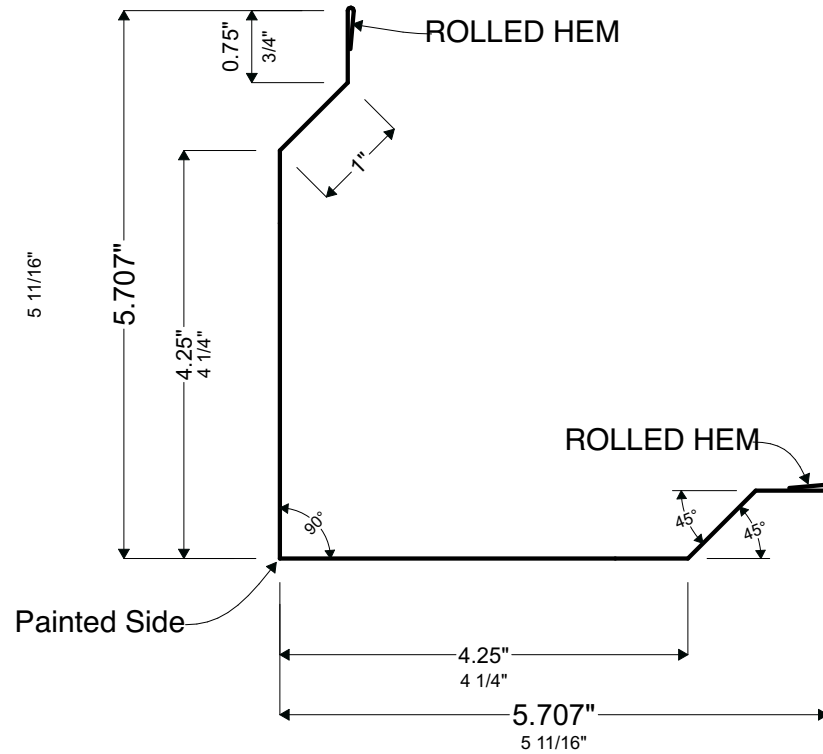

A1 Profile Section Detail
Scale: 6" = 1'-0"

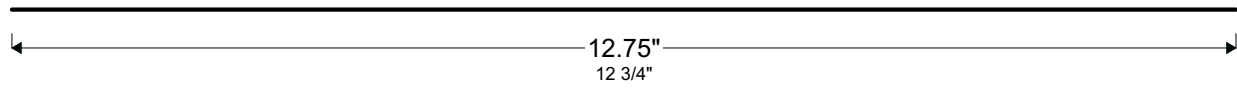

B1 Profile Flat Width Required
Scale: 6" = 1'-0"

TRIM 14 PROPERTY OF IBEX NOT FOR REPRODUCTION WITHOUT PRIOR WRITTEN CONSENT OF IBEX METAL, LLC	TRIM 14
---	----------------

Product ID :	14
Name :	OUTSIDE CORNER
Description :	Outside Corner Trim for Wall Panels



IBEX

IDAHO'S BEST EXTERIORS

Metal Roofing, Siding, and Trim

P: 208-565-3002
www.ibexmetal.com
info@ibexmetal.com

280 Great Northern Road
 Bonners Ferry, ID 83805

1

2

3

FRACTIONS ROUNDED TO NEAREST 1/16"
REVISED: 7/18/23

29 | 26 | 24 | 22

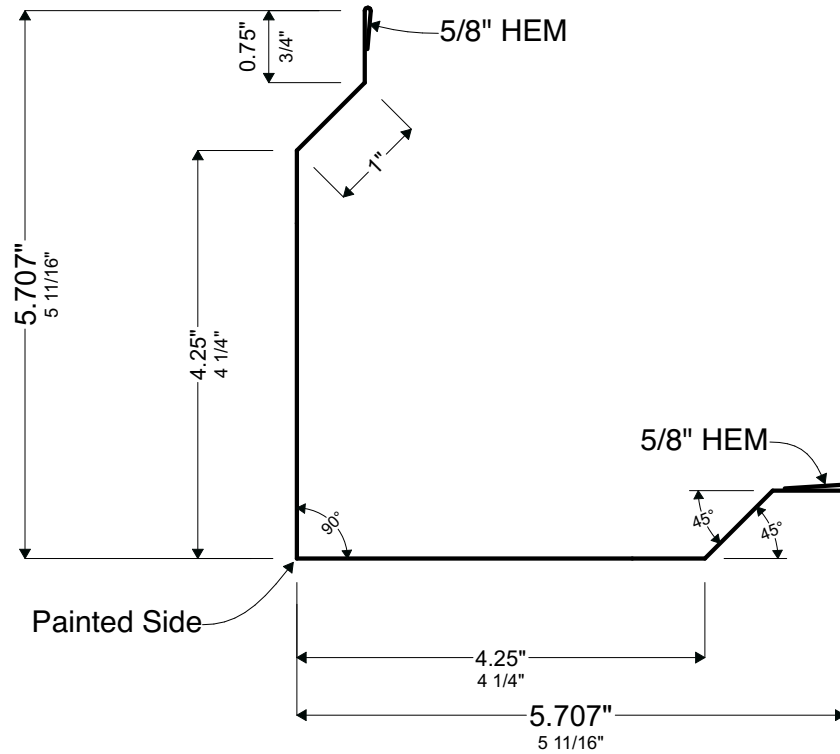

A1 Profile Section Detail
Scale: 6" = 1'-0"

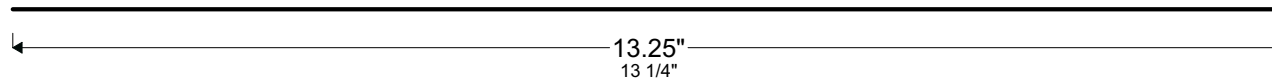

B1 Profile Flat Width Required
Scale: 6" = 1'-0"

TRIM 14F PROPERTY OF IBEX NOT FOR REPRODUCTION WITHOUT PRIOR WRITTEN CONSENT OF IBEX METAL, LLC	TRIM 14F

Product ID :	14F
Name :	FOLDED OUTSIDE CORNER
Description :	Outside Corner Trim for Wall Panels (Folded)



Metal Roofing, Siding, and Trim
 P: 208-565-3002
 www.ibexmetal.com
 info@ibexmetal.com
 280 Great Northern Road
 Bonners Ferry, ID 83805

FRACTIONS ROUNDED TO NEAREST 1/16"
 REVISED: 4/5/23

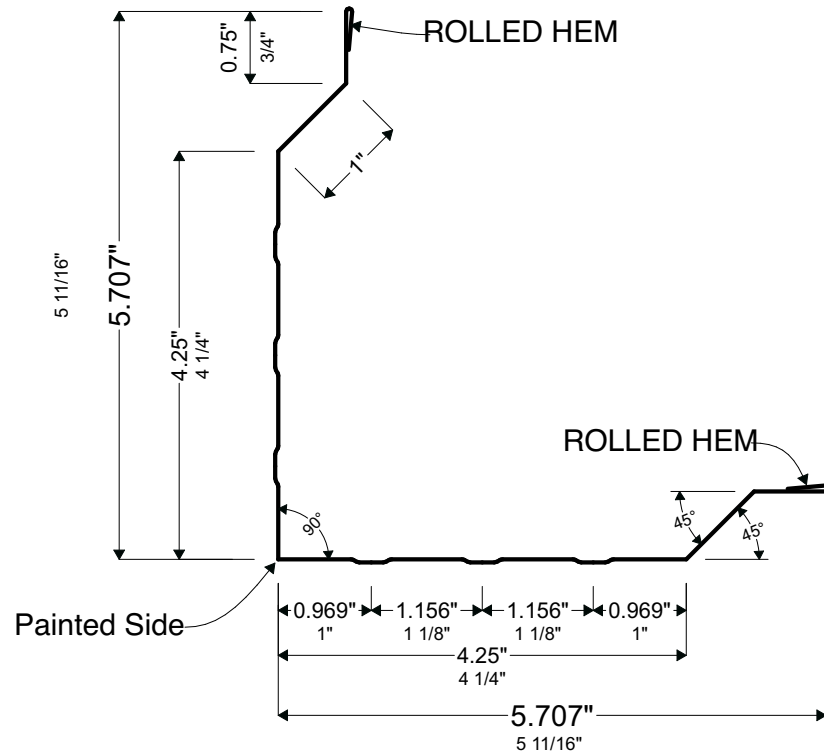

29 | 26

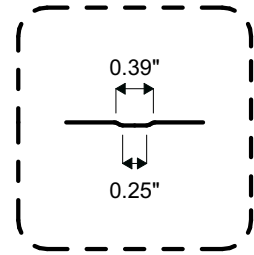

A1 Profile Section Detail
 Scale: 6" = 1'-0"

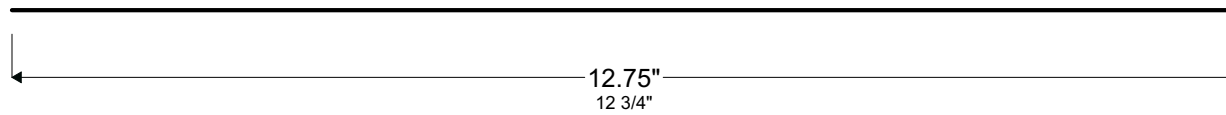

B1 Profile Flat Width Required
 Scale: 6" = 1'-0"

TRIM 14R PROPERTY OF IBEX NOT FOR REPRODUCTION WITHOUT PRIOR WRITTEN CONSENT OF IBEX METAL, LLC	TRIM 14R

Product ID :	14R
Name :	OUTSIDE CORNER (RIBBED)
Description :	Outside Corner Trim for Wall Panels (Ribbed)



Metal Roofing, Siding, and Trim
 P: 208-565-3002
 www.ibexmetal.com
 info@ibexmetal.com
 280 Great Northern Road
 Bonners Ferry, ID 83805

1

2

3

FRACTIONS ROUNDED TO NEAREST 1/16"
REVISED: 4/5/23

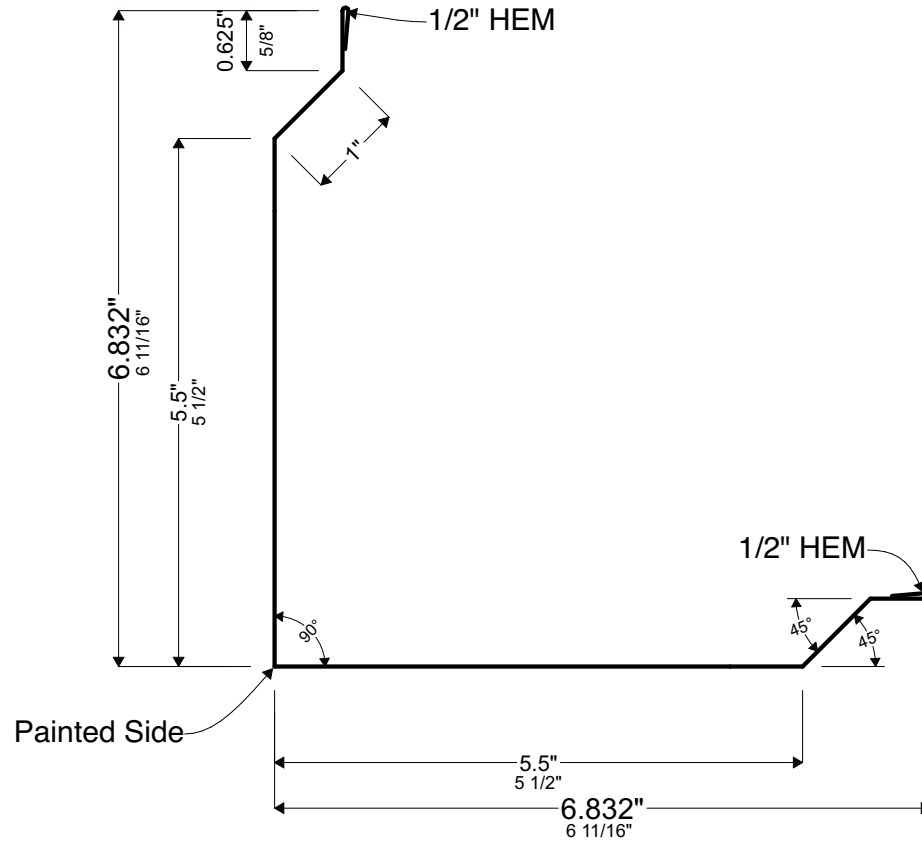

29 | 26 | 24 | 22

A1 Profile Section Detail
Scale: 6" = 1'-0"

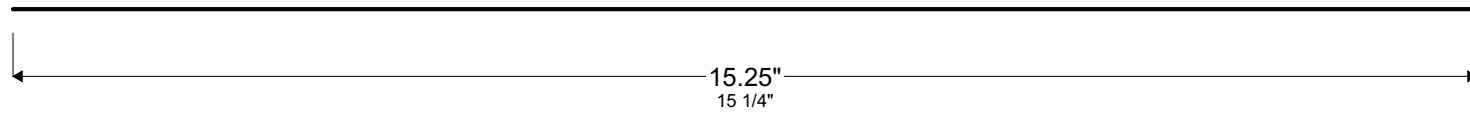

B1 Profile Flat Width Required
Scale: 6" = 1'-0"

TRIM 14B PROPERTY OF IBEX NOT FOR REPRODUCTION WITHOUT PRIOR WRITTEN CONSENT OF IBEX METAL, LLC	TRIM 14B

Product ID :	14B
Name :	OVERSIZE OUTSIDE CORNER
Description :	Large Outside Corner Trim for Wall Panels



Metal Roofing, Siding, and Trim
 P: 208-565-3002
 www.ibexmetal.com
 info@ibexmetal.com
 280 Great Northern Road
 Bonners Ferry, ID 83805

TRIM 14B

1

2

3

FRACTIONS ROUNDED TO NEAREST 1/16"
REVISED: 4/5/23

29 | 26 | 24 | 22

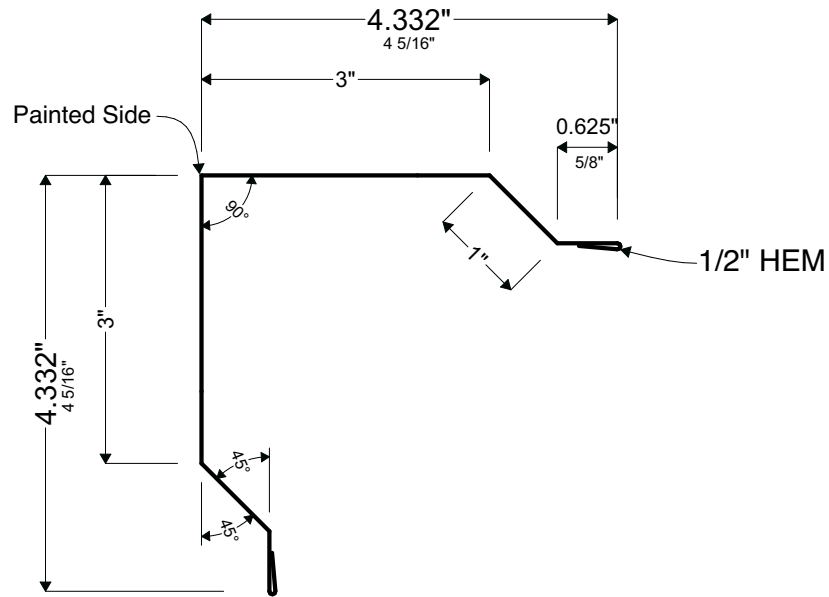

A

A1 Profile Section Detail
Scale: 6" = 1'-0"

A

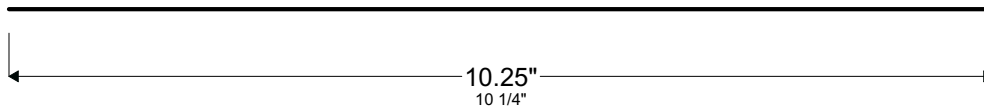

B

B1 Profile Flat Width Required
Scale: 6" = 1'-0"

B

TRIM 14C

PROPERTY OF IBEX
NOT FOR REPRODUCTION WITHOUT PRIOR
WRITTEN CONSENT OF IBEX METAL, LLC

TRIM 14C

Product ID : 14C

Name : MINI OUTSIDE CORNER

Description : Small Outside Corner Trim for Wall Panels



Metal Roofing, Siding, and Trim

P: 208-565-3002
www.ibexmetal.com
info@ibexmetal.com

280 Great Northern Road
Bonners Ferry, ID 83805

1

2

3

FRACTIONS ROUNDED TO NEAREST 1/16"
REVISED: 4/5/23

29 | 26 | 24 | 22

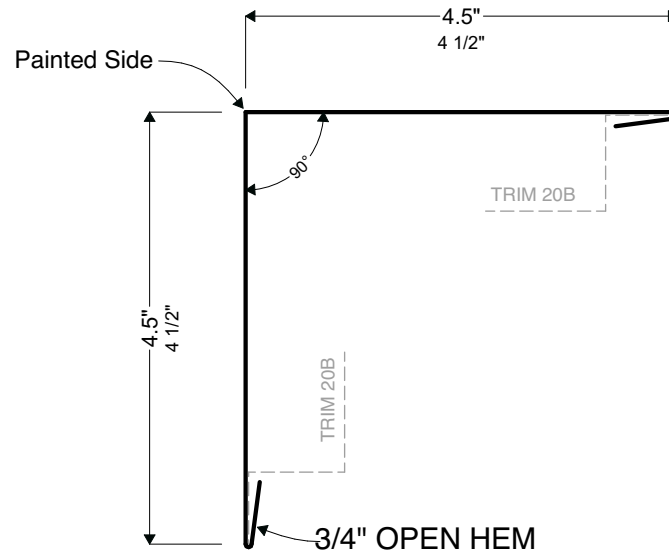

ARCHITECTURAL SERIES

A1 Profile Section Detail
Scale: 6" = 1'-0"

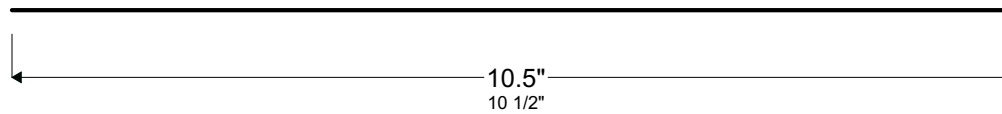

B1 Profile Flat Width Required
Scale: 6" = 1'-0"

TRIM 14D	TRIM 14D
	PROPERTY OF IBEX <small>NOT FOR REPRODUCTION WITHOUT PRIOR WRITTEN CONSENT OF IBEX METAL, LLC</small>

<i>Product ID :</i>	14D
<i>Name :</i>	ARCHITECTURAL OUTSIDE CORNER
<i>Description :</i>	Corner Trim for Concealed Fastener Profiles



Metal Roofing, Siding, and Trim
 P: 208-565-3002
 www.ibexmetal.com
 info@ibexmetal.com
 280 Great Northern Road
 Bonners Ferry, ID 83805

FRACTIONS ROUNDED TO NEAREST 1/16"
 REVISED: 7/18/23

29 | 26 | 24

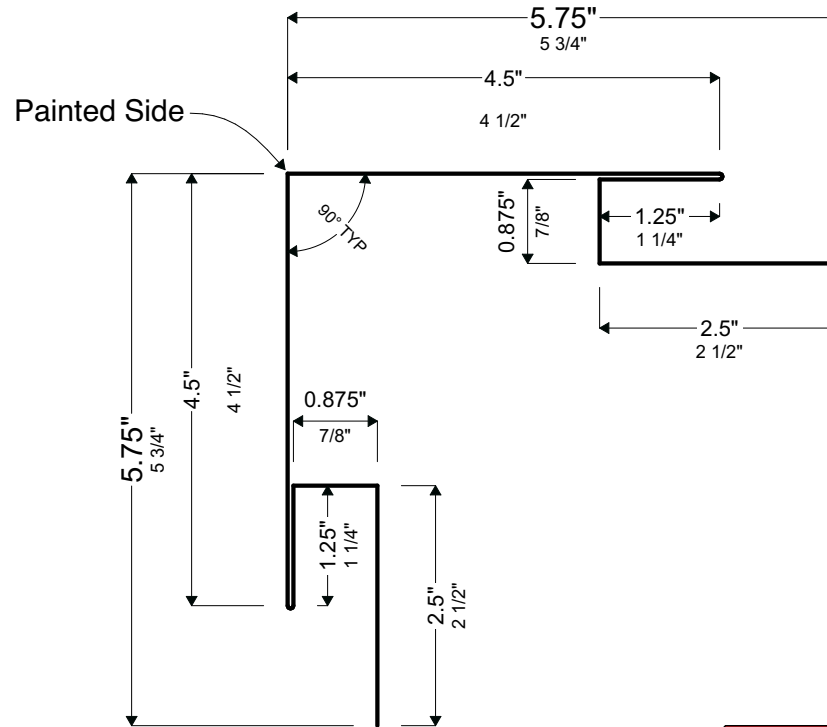

ARCHITECTURAL SERIES

A1 Profile Section Detail
 Scale: 6" = 1'-0"

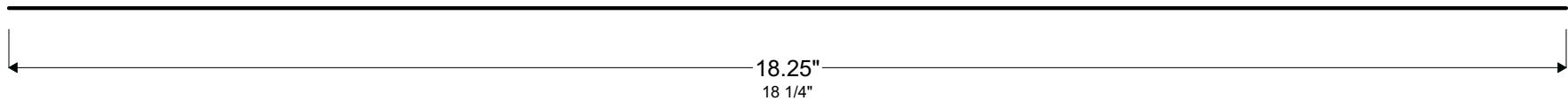

B1 Profile Flat Width Required
 Scale: 6" = 1'-0"

TRIM 14E PROPERTY OF IBEX NOT FOR REPRODUCTION WITHOUT PRIOR WRITTEN CONSENT OF IBEX METAL, LLC	TRIM 14E
--	-----------------

Product ID :	14E
Name :	TRIM FIRST OUTSIDE CORNER
Description :	Siding Outside Corner Trim (Trim First)



Metal Roofing, Siding, and Trim
 P: 208-565-3002
 www.ibexmetal.com
 info@ibexmetal.com
 280 Great Northern Road
 Bonners Ferry, ID 83805

1

2

3

FRACTIONS ROUNDED TO NEAREST 1/16"
REVISED: *Work in Progress*

29 | 26 | 24

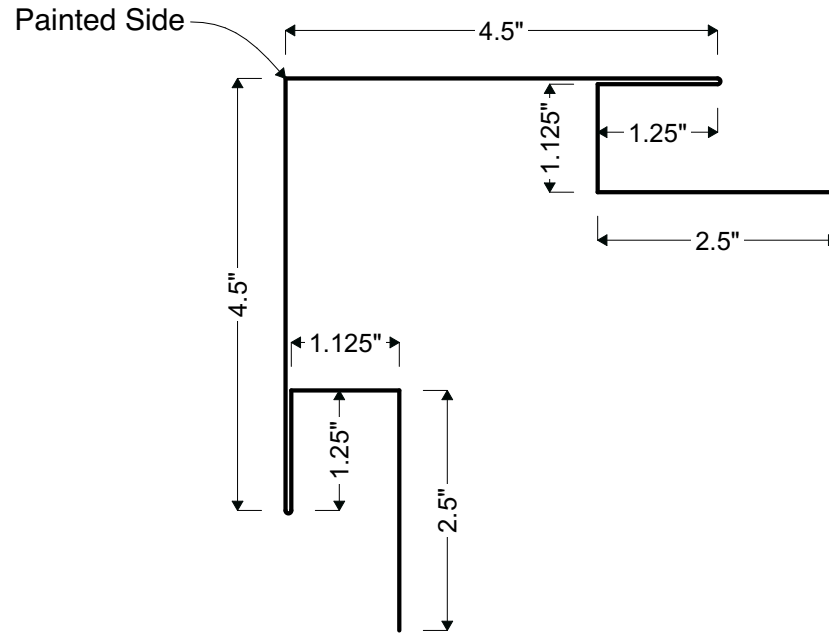

A **A1** Profile Section Detail
Scale: 6" = 1'-0"

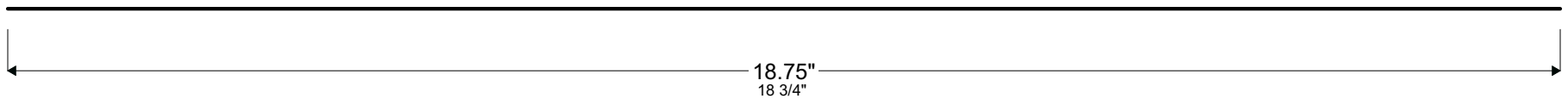

B **B1** Profile Flat Width Required
Scale: 6" = 1'-0"

PROPERTY OF IBEX
 NOT FOR REPRODUCTION WITHOUT PRIOR
 WRITTEN CONSENT OF IBEX METAL, LLC
TRIM 14G

<i>Product ID :</i>	14G
<i>Name :</i>	TRIM FIRST OUTSIDE CORNER (1" RIB)
<i>Description :</i>	Siding Outside Corner for 1" Ribs (TRIM FIRST)



Metal Roofing, Siding, and Trim
 P: 208-565-3002
 www.ibexmetal.com
 info@ibexmetal.com
 280 Great Northern Road
 Bonners Ferry, ID 83805

1

2

3

FRACTIONS ROUNDED TO NEAREST 1/16"
REVISED: 4/5/23

29 | 26 | 24 | 22

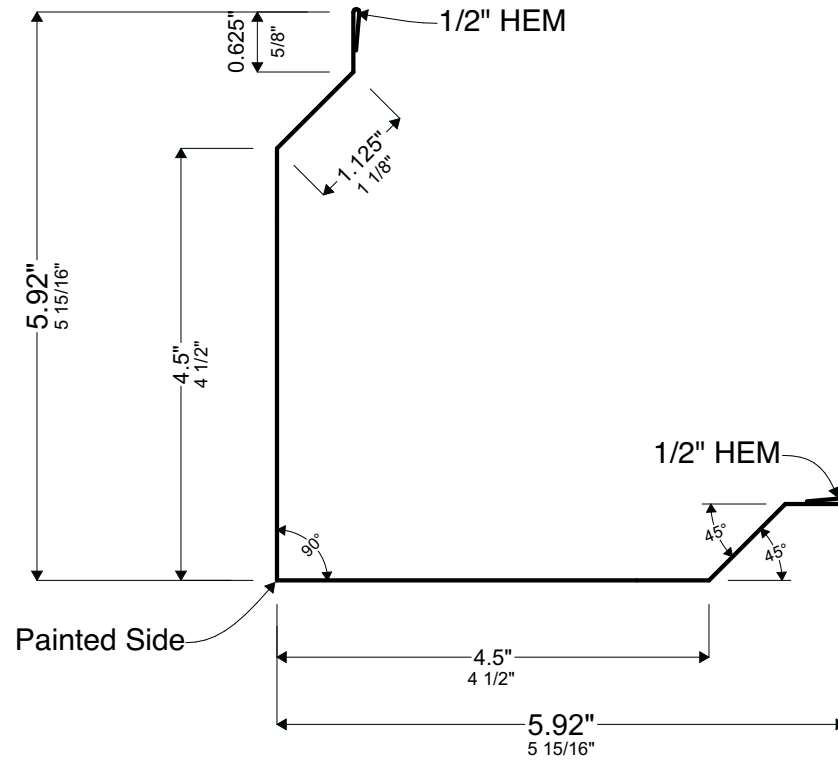

A1 Profile Section Detail
Scale: 6" = 1'-0"

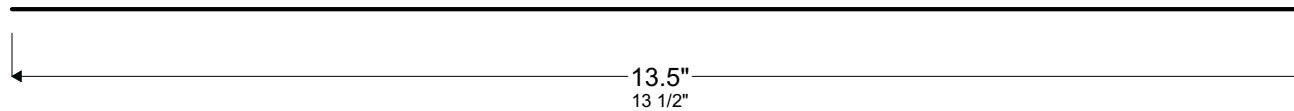

B1 Profile Flat Width Required
Scale: 6" = 1'-0"

TRIM 14H PROPERTY OF IBEX NOT FOR REPRODUCTION WITHOUT PRIOR WRITTEN PERMISSION OF IBEX METAL, LLC	TRIM 14H

Product ID :	14H
Name :	OUTSIDE CORNER (HERITAGE)
Description :	Outside Corner Trim for Wall Panels (Heritage)



Metal Roofing, Siding, and Trim
 P: 208-565-3002
 www.ibexmetal.com
 info@ibexmetal.com
 280 Great Northern Road
 Bonners Ferry, ID 83805

1

2

3

FRACTIONS ROUNDED TO NEAREST 1/16"
REVISED: 12/12/23

29 | 26 | 24 | 22

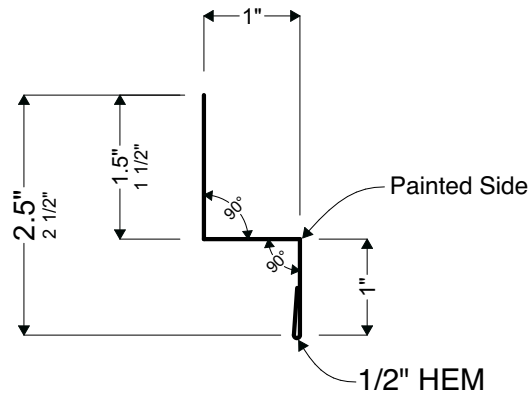

A1 Profile Section Detail
Scale: 6" = 1'-0"

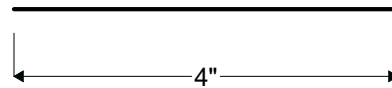

B1 Profile Flat Width Required
Scale: 6" = 1'-0"

TRIM 15	TRIM 15
----------------	----------------

<i>Product ID :</i>	15
<i>Name :</i>	WALL LITE
<i>Description :</i>	Used for Wainscote to Wall Panel Transition



IBEX

IDAHO'S BEST EXTERIORS

Metal Roofing, Siding, and Trim

P: 208-565-3002
www.ibexmetal.com
info@ibexmetal.com

280 Great Northern Road
Bonners Ferry, ID 83805

TRIM 15

PROPERTY OF IBEX
NOT FOR REPRODUCTION WITHOUT PRIOR
WRITTEN CONSENT OF IBEX METAL, LLC

FRACTIONS ROUNDED TO NEAREST 1/16"
 REVISED: 12/12/23

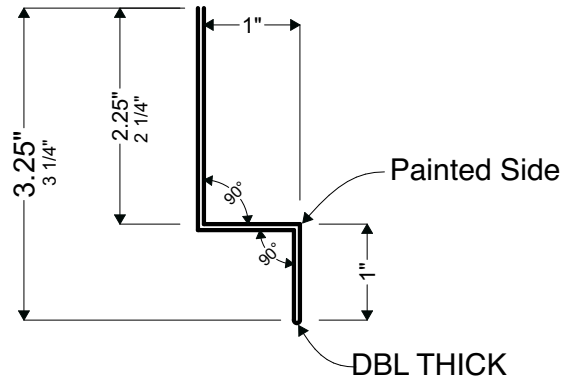

ARCHITECTURAL SERIES

A1 Profile Section Detail
 Scale: 6" = 1'-0"

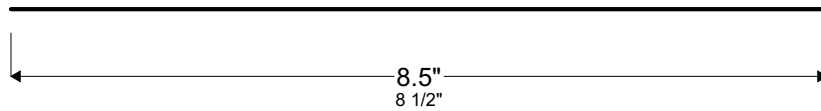

B1 Profile Flat Width Required
 Scale: 6" = 1'-0"

TRIM 15B

PROPERTY OF IBEX
 NOT FOR REPRODUCTION WITHOUT PRIOR
 WRITTEN CONSENT OF IBEX METAL, LLC

<i>Product ID :</i>	15B
<i>Name :</i>	FULL WRAP WALL LITE
<i>Description :</i>	Wainscote to Wall Panel Transition (Paint inside)



IBEX

IDAHO'S BEST EXTERIORS

Metal Roofing, Siding, and Trim
 P: 208-565-3002
 www.ibexmetal.com
 info@ibexmetal.com
 280 Great Northern Road
 Bonners Ferry, ID 83805

1

2

3

FRACTIONS ROUNDED TO NEAREST 1/16"
REVISED: 12/12/23

29 | 26 | 24 | 22

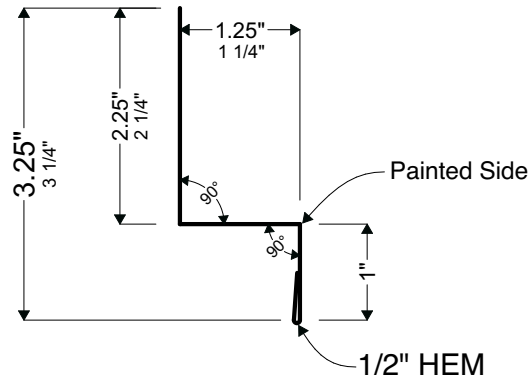

A1 Profile Section Detail
Scale: 6" = 1'-0"

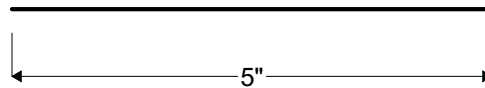

B1 Profile Flat Width Required
Scale: 6" = 1'-0"

TRIM 15C PROPERTY OF IBEX NOT FOR REPRODUCTION WITHOUT PRIOR WRITTEN PERMISSION OF IBEX METAL, LLC	TRIM 15C

Product ID :	15C
Name :	WALL LITE (1" RIB)
Description :	Wainscote to 1" Rib Wall Panel Transition



Metal Roofing, Siding, and Trim
 P: 208-565-3002
 www.ibexmetal.com
 info@ibexmetal.com
 280 Great Northern Road
 Bonners Ferry, ID 83805

1

2

3

FRACTIONS ROUNDED TO NEAREST 1/16"
REVISED: 12/12/23

29 | 26

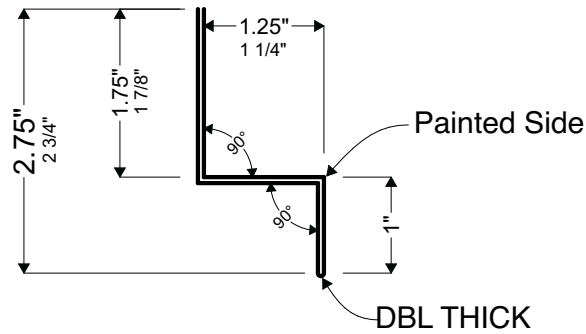

ARCHITECTURAL SERIES

A1 Profile Section Detail
Scale: 6" = 1'-0"

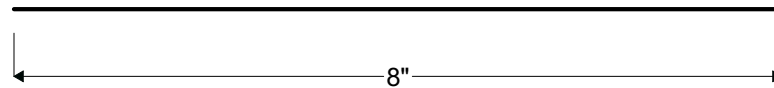

B1 Profile Flat Width Required
Scale: 6" = 1'-0"

PROPERTY OF IBEX NOT FOR REPRODUCTION WITHOUT PRIOR WRITTEN PERMISSION OF IBEX METAL, LLC	TRIM 15D
	TRIM 15D

<i>Product ID :</i>	15D
<i>Name :</i>	FULL WRAP WALL LITE (1" RIB)
<i>Description :</i>	Wainscote to 1" Rib Panel Transition (Paint Inside)



Metal Roofing, Siding, and Trim
 P: 208-565-3002
 www.ibexmetal.com
 info@ibexmetal.com
 280 Great Northern Road
 Bonners Ferry, ID 83805

1

2

3

FRACTIONS ROUNDED TO NEAREST 1/16"
REVISED: 12/12/23

29 | 26 | 24 | 22

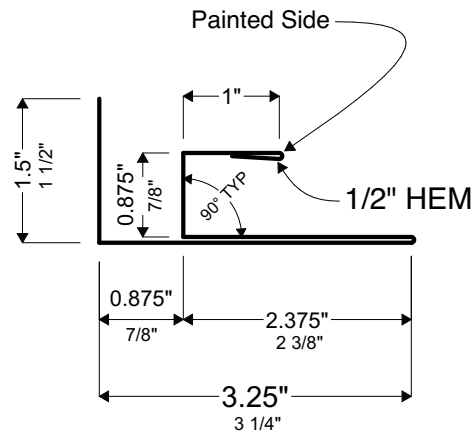

A1 Profile Section Detail
Scale: 6" = 1'-0"

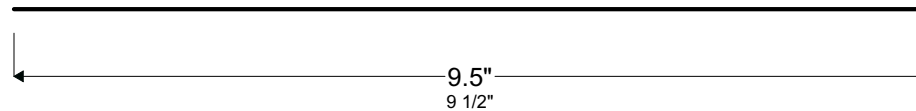

B1 Profile Flat Width Required
Scale: 6" = 1'-0"

TRIM 16

PROPERTY OF IBEX
NOT FOR REPRODUCTION WITHOUT PRIOR
WRITTEN CONSENT OF IBEX METAL, LLC

Product ID :	16
Name :	FJ TRIM
Description :	Trim for 3/4" Rib Siding & 3/4" Soffit



Metal Roofing, Siding, and Trim
P: 208-565-3002
www.ibexmetal.com
info@ibexmetal.com
280 Great Northern Road
Bonners Ferry, ID 83805

1

2

3

FRACTIONS ROUNDED TO NEAREST 1/16"
REVISED: 12/12/23

29 | 26 | 24 | 22

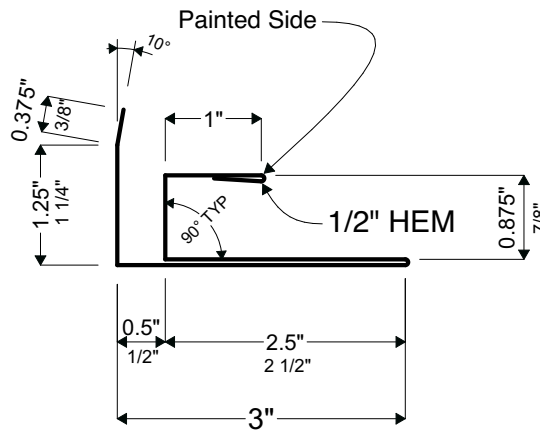

A1 Profile Section Detail
Scale: 6" = 1'-0"

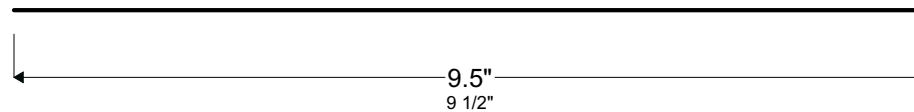

B1 Profile Flat Width Required
Scale: 6" = 1'-0"

TRIM 16B PROPERTY OF IBEX NOT FOR REPRODUCTION WITHOUT PRIOR WRITTEN PERMISSION OF IBEX METAL, LLC	TRIM 16B
---	-----------------

Product ID :	16B
Name :	MINI FJ TRIM
Description :	FJ Trim for 3/4" Rib Siding & Regular Soffit



Metal Roofing, Siding, and Trim
 P: 208-565-3002
 www.ibexmetal.com
 info@ibexmetal.com
 280 Great Northern Road
 Bonners Ferry, ID 83805

1

2

3

FRACTIONS ROUNDED TO NEAREST 1/16"
REVISED: 12/12/23

29 | 26

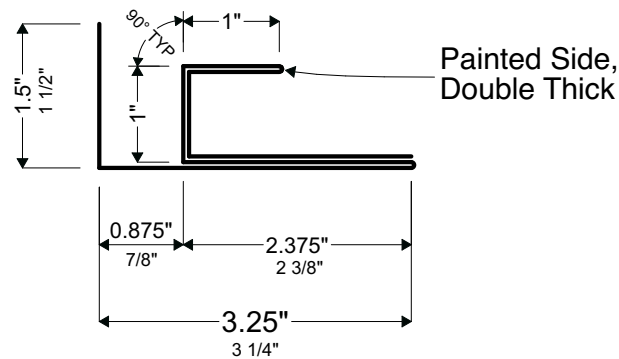

ARCHITECTURAL SERIES

A1 Profile Section Detail
Scale: 6" = 1'-0"

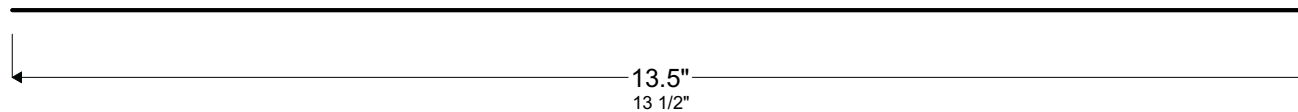

B1 Profile Flat Width Required
Scale: 6" = 1'-0"

TRIM 16C PROPERTY OF IBEX NOT FOR REPRODUCTION WITHOUT PRIOR WRITTEN PERMISSION OF IBEX METAL, LLC	TRIM 16C

<i>Product ID :</i>	16C
<i>Name :</i>	FULL WRAP FJ TRIM
<i>Description :</i>	Standard FJ Trim w/Paint inside



Metal Roofing, Siding, and Trim
 P: 208-565-3002
 www.ibexmetal.com
 info@ibexmetal.com
 280 Great Northern Road
 Bonners Ferry, ID 83805

TRIM 16C

1

2

3

FRACTIONS ROUNDED TO NEAREST 1/16"
REVISED: 12/12/23

29 | 26

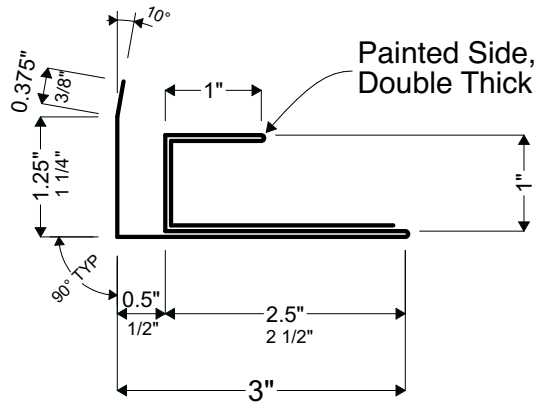

ARCHITECTURAL SERIES

A1 Profile Section Detail
Scale: 6" = 1'-0"

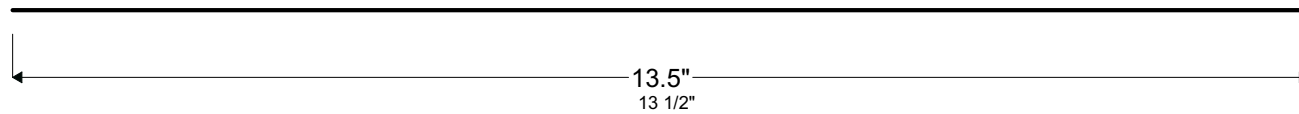

B1 Profile Flat Width Required
Scale: 6" = 1'-0"

PROPERTY OF IBEX NOT FOR REPRODUCTION WITHOUT PRIOR WRITTEN CONSENT OF IBEX METAL, LLC	TRIM 16D
	TRIM 16D

<i>Product ID :</i>	16D
<i>Name :</i>	FULL WRAP MINI FJ TRIM
<i>Description :</i>	FJ Trim for 3/4" Rib Siding and Regular Soffit w/ Paint Inside



Metal Roofing, Siding, and Trim
 P: 208-565-3002
 www.ibexmetal.com
 info@ibexmetal.com
 280 Great Northern Road
 Bonners Ferry, ID 83805

1

2

3

FRACTIONS ROUNDED TO NEAREST 1/16"
REVISED: 12/12/23

29 | 26 | 24 | 22

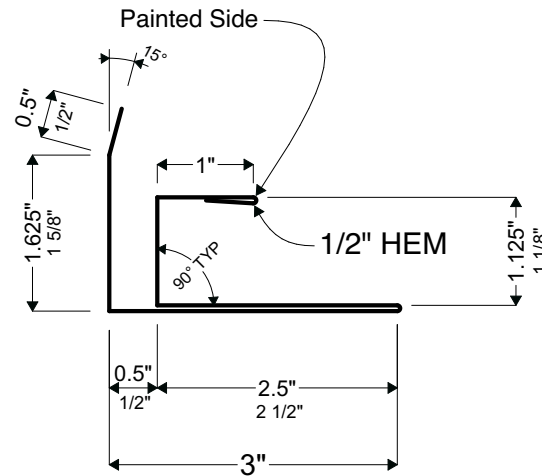

A1 Profile Section Detail
Scale: 6" = 1'-0"

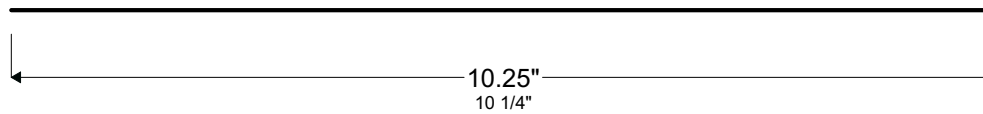

B1 Profile Flat Width Required
Scale: 6" = 1'-0"

TRIM 16E PROPERTY OF IBEX NOT FOR REPRODUCTION WITHOUT PRIOR WRITTEN CONSENT OF IBEX METAL, LLC	TRIM 16E

Product ID :	16E
Name :	MINI FJ TRIM (1" RIB)
Description :	FJ Trim for Regular Soffit and 1" Rib Wall Panels



Metal Roofing, Siding, and Trim
 P: 208-565-3002
 www.ibexmetal.com
 info@ibexmetal.com
 280 Great Northern Road
 Bonners Ferry, ID 83805

1

2

3

FRACTIONS ROUNDED TO NEAREST 1/16"
REVISED: 12/12/23

29 | 26

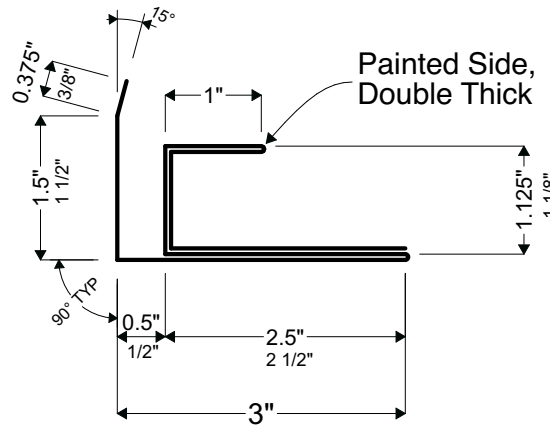

ARCHITECTURAL SERIES

A1 Profile Section Detail
Scale: 6" = 1'-0"

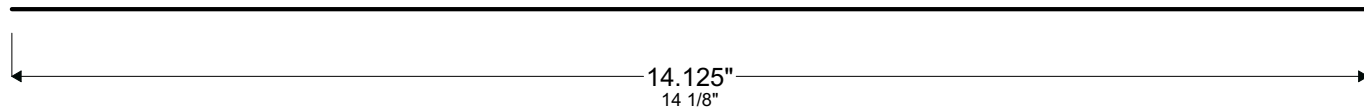

B1 Profile Flat Width Required
Scale: 6" = 1'-0"

TRIM 16F

<i>Product ID :</i>	16F
<i>Name :</i>	FULL WRAP MINI FJ TRIM (1" RIB)
<i>Description :</i>	FJ Trim for Regular Soffit and 1" Rib Wall Panels w/Paint Inside



Metal Roofing, Siding, and Trim
 P: 208-565-3002
 www.ibexmetal.com
 info@ibexmetal.com
 280 Great Northern Road
 Bonners Ferry, ID 83805

TRIM 16F

PROPERTY OF IBEX
NOT FOR REPRODUCTION WITHOUT PRIOR
WRITTEN PERMISSION OF IBEX METAL, LLC

1

2

3

FRACTIONS ROUNDED TO NEAREST 1/16"
REVISED: *Work in Progress*

29 | 26 | 24 | 22

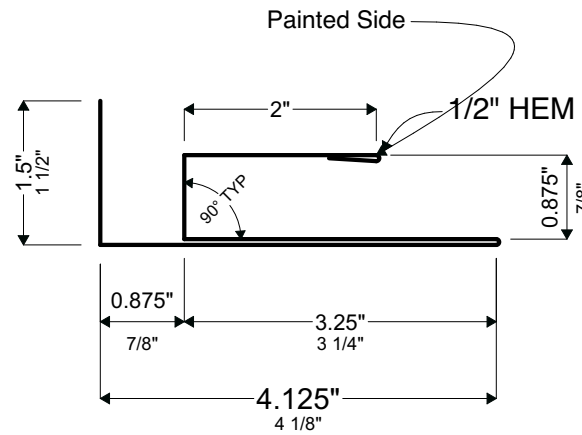

A1 Profile Section Detail
Scale: 6" = 1'-0"

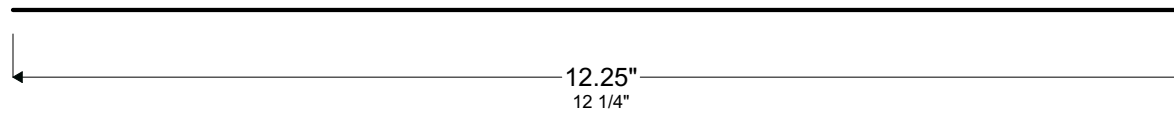

B1 Profile Flat Width Required
Scale: 6" = 1'-0"

TRIM 16G

PROPERTY OF IBEX
NOT FOR REPRODUCTION WITHOUT PRIOR
WRITTEN CONSENT OF IBEX METAL, LLC

<i>Product ID :</i>	16G
<i>Name :</i>	FJ TRIM (2" FACE)
<i>Description :</i>	FJ Trim with 2" Exposed Face



Metal Roofing, Siding, and Trim
 P: 208-565-3002
 www.ibexmetal.com
 info@ibexmetal.com
 280 Great Northern Road
 Bonners Ferry, ID 83805

1

2

3

FRACTIONS ROUNDED TO NEAREST 1/16"
REVISED: *Work in Progress*

29 | 26 | 24 | 22

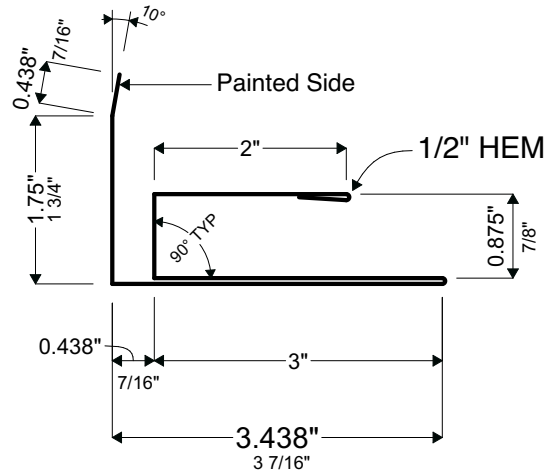

A1 Profile Section Detail
Scale: 6" = 1'-0"

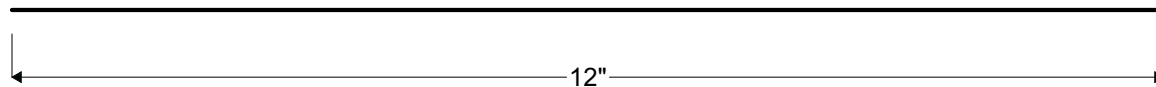

B1 Profile Flat Width Required
Scale: 6" = 1'-0"

TRIM 16J PROPERTY OF IBEX NOT FOR REPRODUCTION WITHOUT PRIOR WRITTEN PERMISSION OF IBEX METAL, LLC	TRIM 16J
---	-----------------

Product ID :	16J
Name :	MINI FJ TRIM (2" FACE)
Description :	Smaller FJ Trim for Soffit with 2" Exposed Face



Metal Roofing, Siding, and Trim
 P: 208-565-3002
 www.ibexmetal.com
 info@ibexmetal.com
 280 Great Northern Road
 Bonners Ferry, ID 83805

1

2

3

FRACTIONS ROUNDED TO NEAREST 1/16"
REVISED: 12/12/23

29 | 26 | 24 | 22

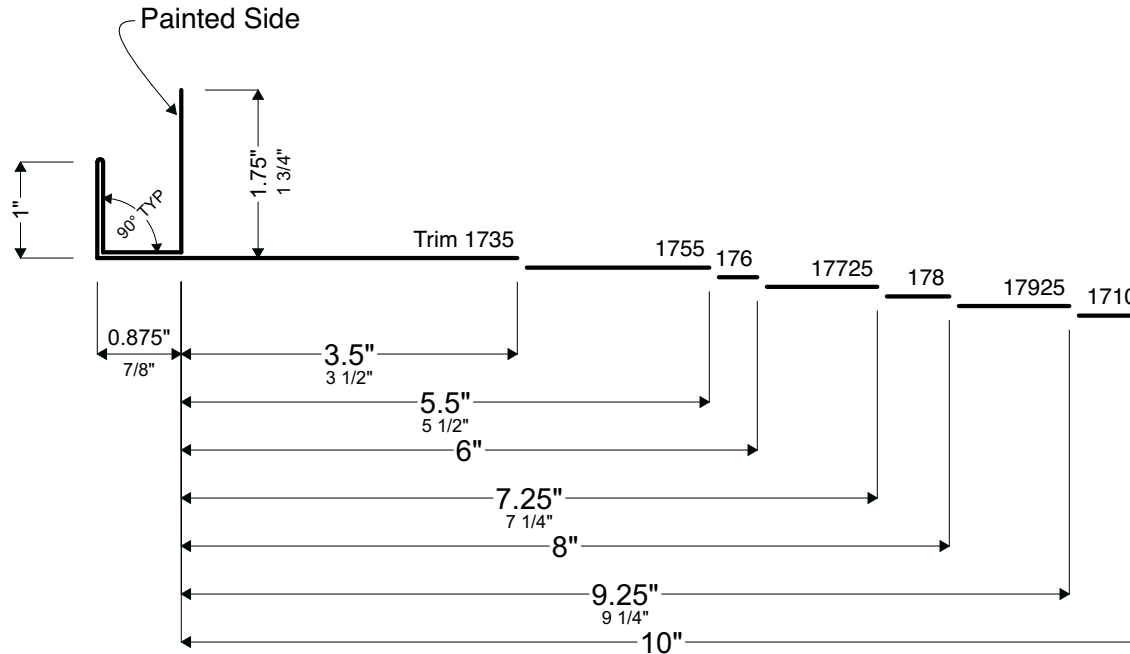

A1 Profile Section Detail
Scale: 6" = 1'-0"

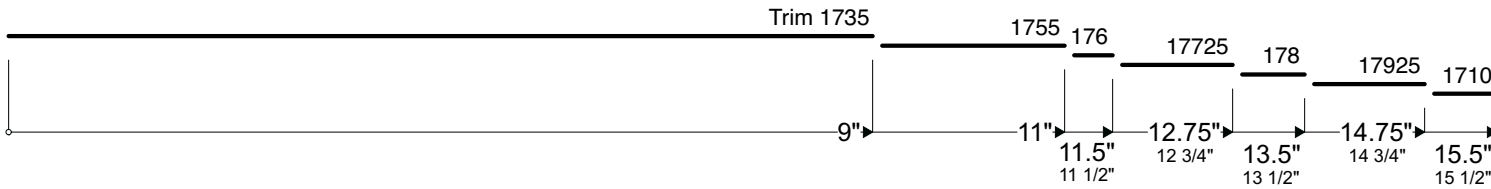

B1 Profile Flat Width Required
Scale: 6" = 1'-0"

TRIM 17 PROPERTY OF IBEX NOT FOR REPRODUCTION WITHOUT PRIOR WRITTEN CONSENT OF IBEX METAL, LLC TRIM 17	TRIM 17

Product ID :	1735 - 1710
Name :	POST FJ TRIM
Description :	Post Flashing Trim for Panel Attachment



Metal Roofing, Siding, and Trim
 P: 208-565-3002
 www.ibexmetal.com
 info@ibexmetal.com
 280 Great Northern Road
 Bonners Ferry, ID 83805

1

2

3

FRACTIONS ROUNDED TO NEAREST 1/16"
REVISED: *Work in Progress*

29 | 26 | 24 | 22

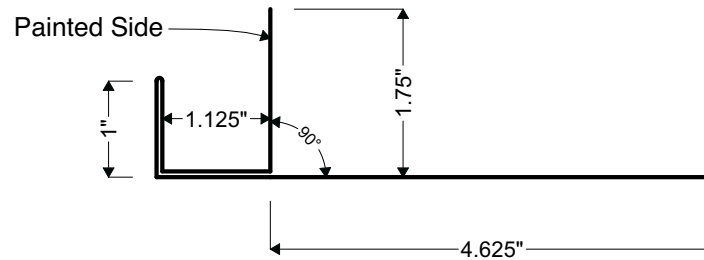

A1 Profile Section Detail
Scale: 6" = 1'-0"

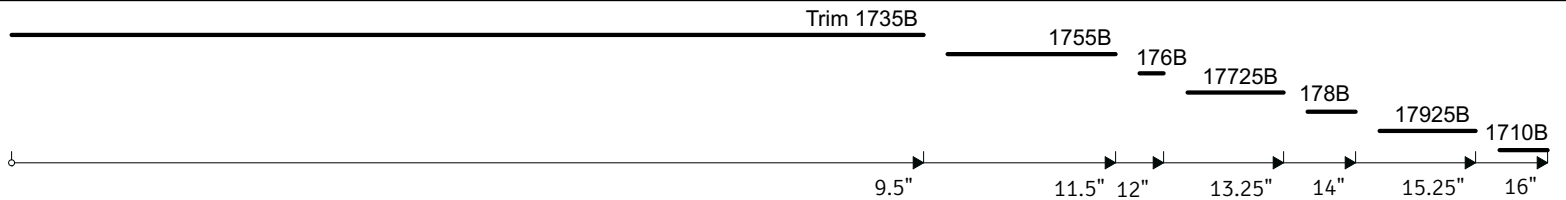

B1 Profile Flat Width Required
Scale: 6" = 1'-0"

TRIM 17B PROPERTY OF IBEX NOT FOR REPRODUCTION WITHOUT PRIOR WRITTEN CONSENT OF IBEX METAL, LLC	TRIM 17B

<i>Product ID :</i>	1735B - 1710B
<i>Name :</i>	POST FJ TRIM (1" RIB)
<i>Description :</i>	Post Flashing Trim for 1" Rib Panel Attachment



Metal Roofing, Siding, and Trim
 P: 208-565-3002
 www.ibexmetal.com
 info@ibexmetal.com
 280 Great Northern Road
 Bonners Ferry, ID 83805

1

2

3

FRACTIONS ROUNDED TO NEAREST 1/16"
REVISED: *Work in Progress*

29 | 26 | 24 | 22

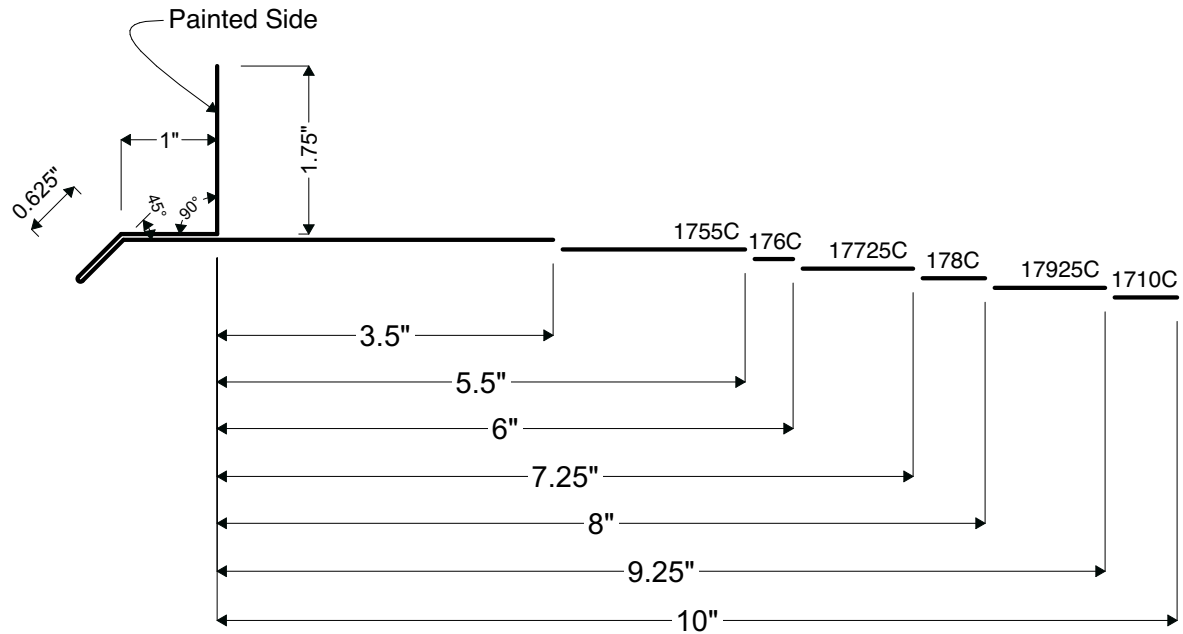

A1 Profile Section Detail
Scale: 6" = 1'-0"

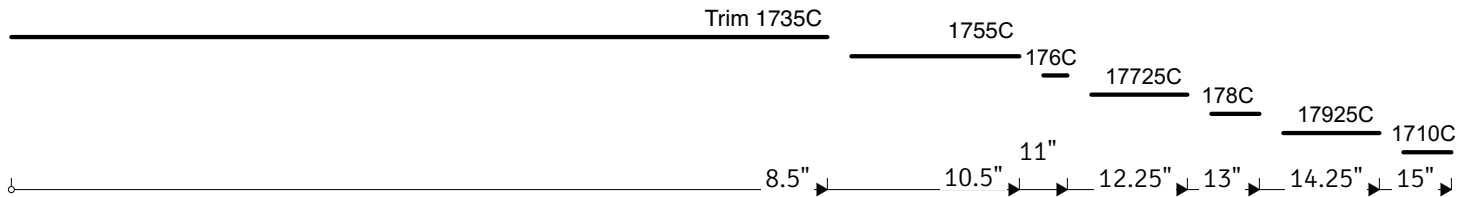

B1 Profile Flat Width Required
Scale: 6" = 1'-0"

PROPERTY OF IBEX NOT FOR REPRODUCTION WITHOUT PRIOR WRITTEN PERMISSION OF IBEX METAL, LLC	TRIM 17C

<i>Product ID :</i>	1735C - 1710C
<i>Name :</i>	HEADER TRIM
<i>Description :</i>	Header Flashing Trim for Panel Attachment



Metal Roofing, Siding, and Trim
 P: 208-565-3002
 www.ibexmetal.com
 info@ibexmetal.com
 280 Great Northern Road
 Bonners Ferry, ID 83805

TRIM 17C

1

2

3

FRACTIONS ROUNDED TO NEAREST 1/16"
REVISED: *Work in Progress*

29 | 26 | 24 | 22

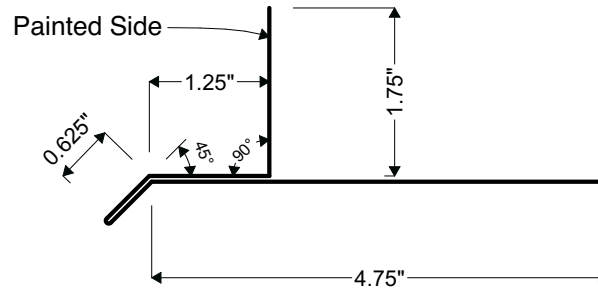

A1 Profile Section Detail
Scale: 6" = 1'-0"

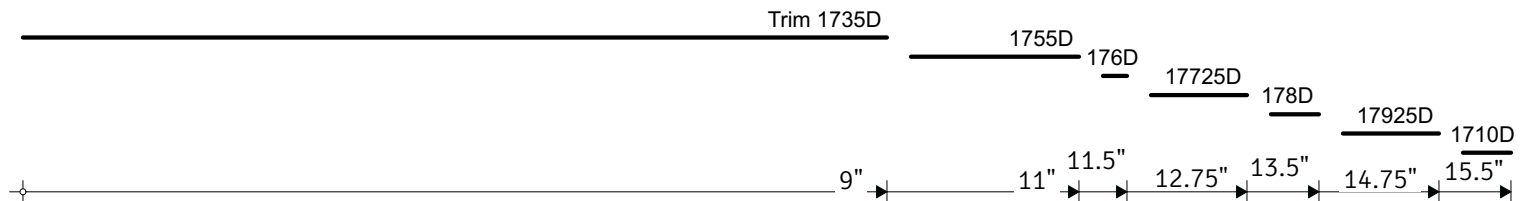

B1 Profile Flat Width Required
Scale: 6" = 1'-0"

TRIM 17D

PROPERTY OF IBEX
NOT FOR REPRODUCTION WITHOUT PRIOR
WRITTEN CONSENT OF IBEX METAL, LLC

<i>Product ID :</i>	1735D - 1710D
<i>Name :</i>	HEADER TRIM (1" RIB)
<i>Description :</i>	Header Flashing Trim for 1" Rib Panel Attachment



IBEX

IDAHO'S BEST EXTERIORS

Metal Roofing, Siding, and Trim

P: 208-565-3002
www.ibexmetal.com
info@ibexmetal.com

280 Great Northern Road
Bonners Ferry, ID 83805

1

2

3

FRACTIONS ROUNDED TO NEAREST 1/16"
REVISED: 12/12/23

29 | 26 | 24 | 22

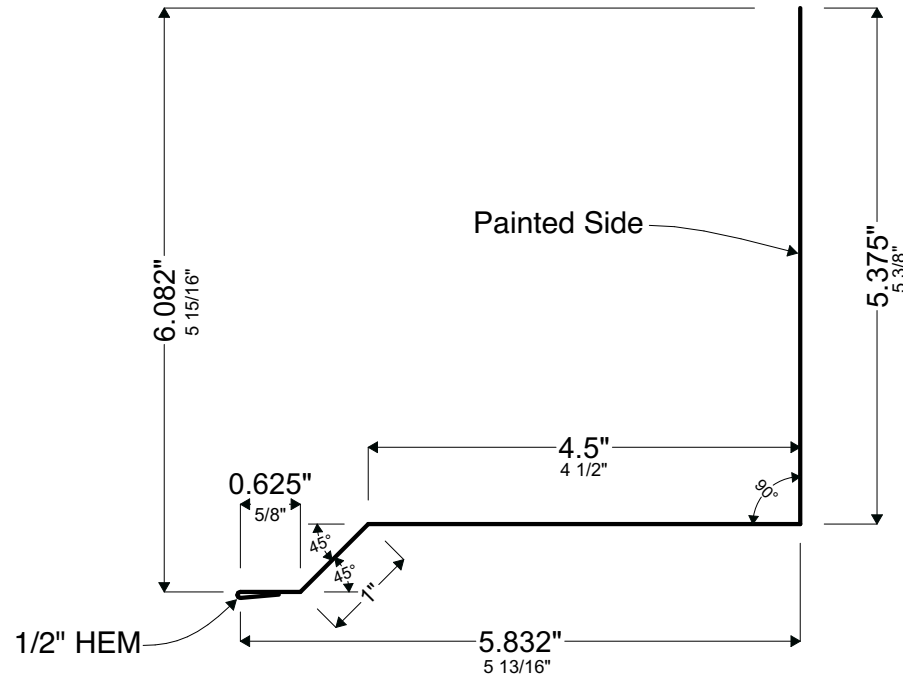

A1 Profile Section Detail
Scale: 6" = 1'-0"

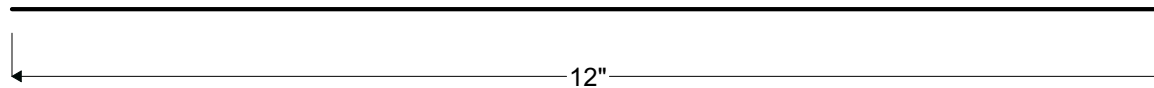

B1 Profile Flat Width Required
Scale: 6" = 1'-0"

TRIM 18 PROPERTY OF IBEX NOT FOR REPRODUCTION WITHOUT PRIOR WRITTEN PERMISSION OF IBEX METAL, LLC	TRIM 18
--	----------------

<i>Product ID :</i>	18
<i>Name :</i>	ROOF TO WALL
<i>Description :</i>	Roof to Wall Transition Flashing (Sidewall)



Metal Roofing, Siding, and Trim
 P: 208-565-3002
 www.ibexmetal.com
 info@ibexmetal.com
 280 Great Northern Road
 Bonners Ferry, ID 83805

TRIM 18

1

2

3

FRACTIONS ROUNDED TO NEAREST 1/16"
REVISED: 4/5/23

29 | 26 | 24

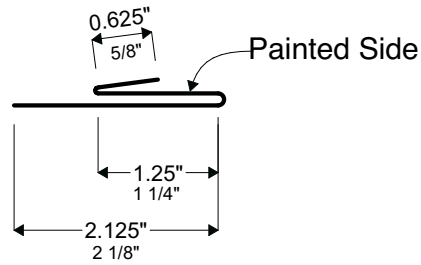

ARCHITECTURAL SERIES

A **A1** Profile Section Detail
Scale: 6" = 1'-0"

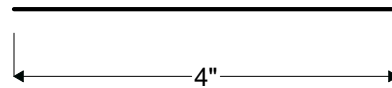

B **B1** Profile Flat Width Required
Scale: 6" = 1'-0"

TRIM 19 PROPERTY OF IBEX NOT FOR REPRODUCTION WITHOUT PRIOR WRITTEN CONSENT OF IBEX METAL, LLC	TRIM 19
---	----------------

<i>Product ID :</i>	19
<i>Name :</i>	BOARD & BATT TRIM
<i>Description :</i>	Used as Concealed Fastener



Metal Roofing, Siding, and Trim

P: 208-565-3002
www.ibexmetal.com
info@ibexmetal.com

280 Great Northern Road
Bonners Ferry, ID 83805

TRIM 19

1

2

3

FRACTIONS ROUNDED TO NEAREST 1/16"
REVISED: *Work in Progress*

29 | 26 | 24

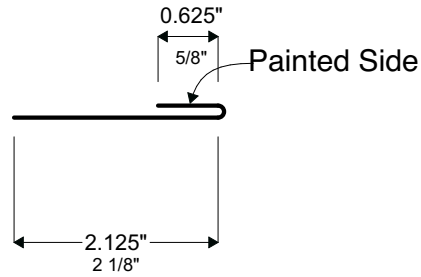

ARCHITECTURAL SERIES

A

A1 Profile Section Detail
Scale: 6" = 1'-0"

A

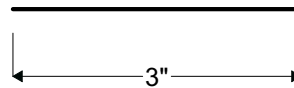

B

B1 Profile Flat Width Required
Scale: 6" = 1'-0"

B

TRIM 19B

PROPERTY OF IBEX NOT FOR REPRODUCTION WITHOUT PRIOR WRITTEN CONSENT OF IBEX METAL, LLC	TRIM 19B
---	-----------------

<i>Product ID :</i>	19B
<i>Name :</i>	OPEN HEM CLEAT
<i>Description :</i>	Used as Concealed Fastener



Metal Roofing, Siding, and Trim
 P: 208-565-3002
 www.ibexmetal.com
 info@ibexmetal.com
 280 Great Northern Road
 Bonners Ferry, ID 83805

1

2

3

FRACTIONS ROUNDED TO NEAREST 1/16"
REVISED: 12/12/23

29 | 26 | 24 | 22

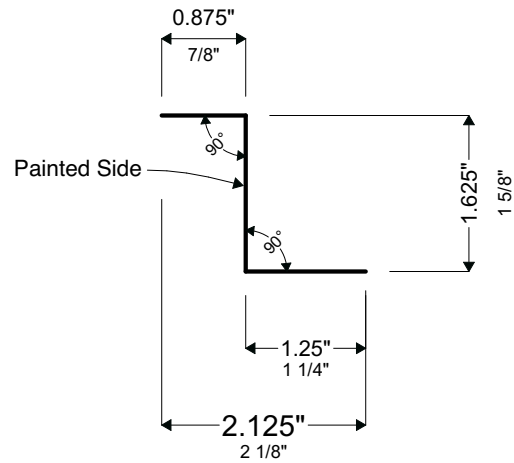

ARCHITECTURAL SERIES

A1 Profile Section Detail
Scale: 6" = 1'-0"

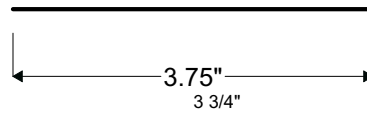

B1 Profile Flat Width Required
Scale: 6" = 1'-0"

TRIM 20

PROPERTY OF IBEX
NOT FOR REPRODUCTION WITHOUT PRIOR
WRITTEN PERMISSION OF IBEX METAL, LLC

TRIM 20

<i>Product ID :</i>	20
<i>Name :</i>	Z TRIM (1.5" Rib)
<i>Description :</i>	Typically Used with 1.5" Rib Concealed Fastener Profiles



Metal Roofing, Siding, and Trim

P: 208-565-3002
www.ibexmetal.com
info@ibexmetal.com

280 Great Northern Road
Bonners Ferry, ID 83805

FRACTIONS ROUNDED TO NEAREST 1/16"
 REVISED: 12/12/23

29 | 26 | 24 | 22

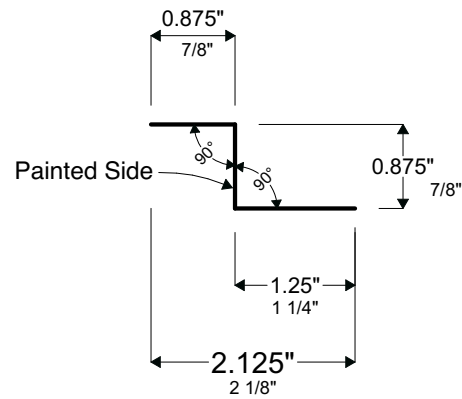

ARCHITECTURAL SERIES

A1 Profile Section Detail
 Scale: 6" = 1'-0"

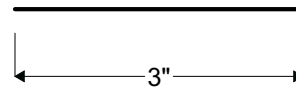

B1 Profile Flat Width Required
 Scale: 6" = 1'-0"

TRIM 20B	PROPERTY OF IBEX NOT FOR REPRODUCTION WITHOUT PRIOR WRITTEN CONSENT OF IBEX METAL, LLC
-----------------	--

<i>Product ID :</i>	20B
<i>Name :</i>	Z Trim B (1" Rib)
<i>Description :</i>	Typically Used with Board & Batten Siding & 1" Rib Concealed Fastener Profiles



Metal Roofing, Siding, and Trim
 P: 208-565-3002
 www.ibexmetal.com
 info@ibexmetal.com
 280 Great Northern Road
 Bonners Ferry, ID 83805

FRACTIONS ROUNDED TO NEAREST 1/16"
 REVISED: 12/12/23

29 | 26 | 24 | 22

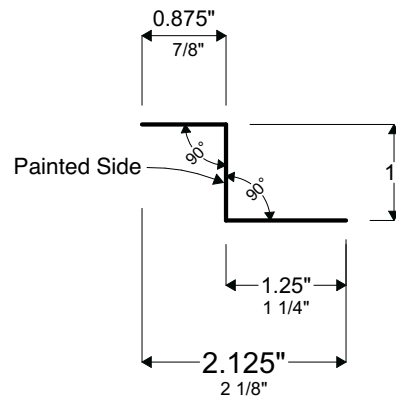

ARCHITECTURAL SERIES

A1 Profile Section Detail
 Scale: 6" = 1'-0"

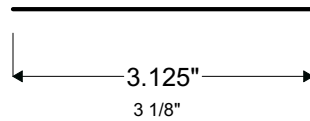

B1 Profile Flat Width Required
 Scale: 6" = 1'-0"

TRIM 20C
PROPERTY OF IBEX
 NOT FOR REPRODUCTION WITHOUT PRIOR
 WRITTEN CONSENT OF IBEX METAL, LLC
TRIM 20C

<i>Product ID :</i>	20C
<i>Name :</i>	Z TRIM C (HERITAGE)
<i>Description :</i>	Typically Used w/Snaplock Panel Trim



IBEX

IDAHO'S BEST EXTERIORS

Metal Roofing, Siding, and Trim

P: 208-565-3002
 www.ibexmetal.com
 info@ibexmetal.com

280 Great Northern Road
 Bonners Ferry, ID 83805

FRACTIONS ROUNDED TO NEAREST 1/16"
 REVISED: 12/12/23

26 | 24 | 22

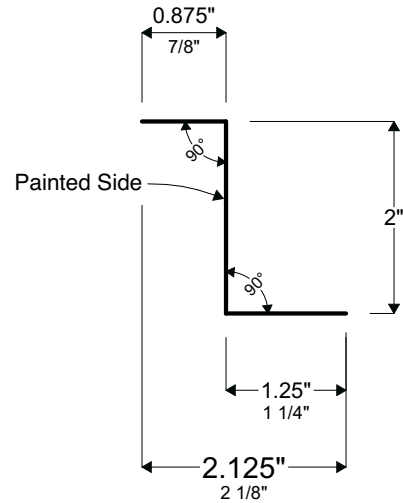

ARCHITECTURAL SERIES

A1 Profile Section Detail
 Scale: 6" = 1'-0"

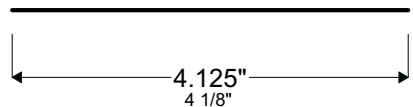

B1 Profile Flat Width Required
 Scale: 6" = 1'-0"

TRIM 20D
PROPERTY OF IBEX
 NOT FOR REPRODUCTION WITHOUT PRIOR
 WRITTEN CONSENT OF IBEX METAL, LLC
TRIM 20D

<i>Product ID :</i>	20D
<i>Name :</i>	Z TRIM D (2" Rib)
<i>Description :</i>	Typically Used with 2" Rib Concealed Fastener Profiles



IBEX

IDAHO'S BEST EXTERIORS

Metal Roofing, Siding, and Trim

P: 208-565-3002
 www.ibexmetal.com
 info@ibexmetal.com

280 Great Northern Road
 Bonners Ferry, ID 83805

1

2

3

FRACTIONS ROUNDED TO NEAREST 1/16"
REVISED: *Work in Progress*

29 | 26 | 24

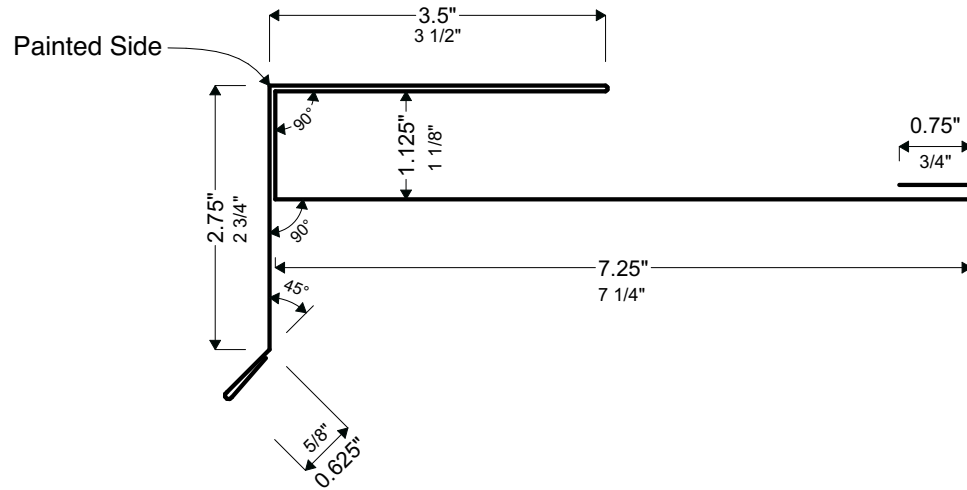

A1 Profile Section Detail
Scale: 6" = 1'-0"

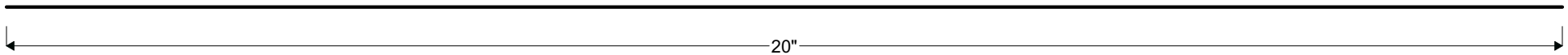

B1 Profile Flat Width Required
Scale: 6" = 1'-0"

TRIM 21 PROPERTY OF IBEX NOT FOR REPRODUCTION WITHOUT PRIOR WRITTEN CONSENT OF IBEX METAL, LLC	TRIM 21
---	----------------

<i>Product ID :</i>	21
<i>Name :</i>	TRIM FIRST RAKE (1" RIB)
<i>Description :</i>	Gable Trim for 1" Standing Seam Profiles (Trim First)



Metal Roofing, Siding, and Trim
 P: 208-565-3002
 www.ibexmetal.com
 info@ibexmetal.com
 280 Great Northern Road
 Bonners Ferry, ID 83805

1

2

3

FRACTIONS ROUNDED TO NEAREST 1/16"
REVISED: *Work in Progress*

29 | 26 | 24

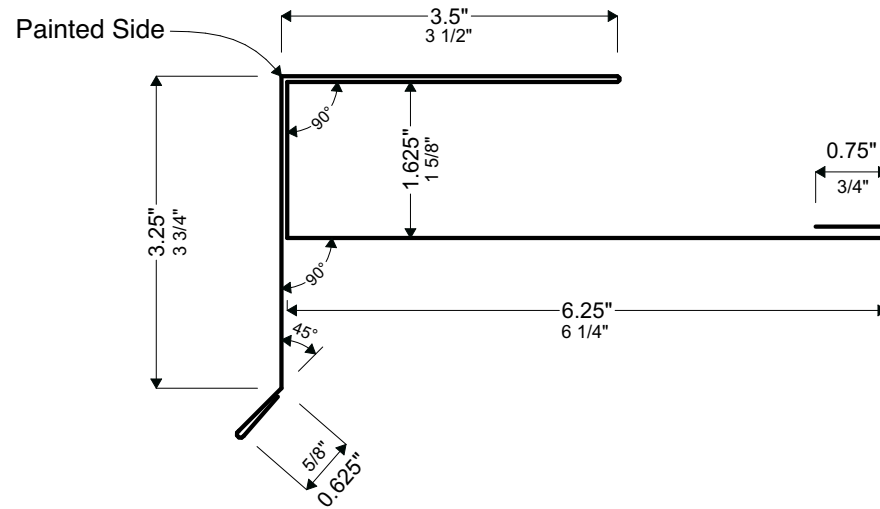

A1 Profile Section Detail
Scale: 6" = 1'-0"

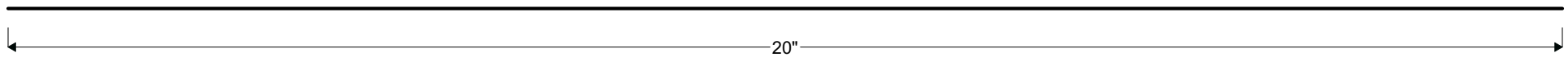

B1 Profile Flat Width Required
Scale: 6" = 1'-0"

TRIM 21B	TRIM 21B
-----------------	-----------------

<i>Product ID :</i>	21B
<i>Name :</i>	TRIM FIRST RAKE (1.5" RIB)
<i>Description :</i>	Gable Trim for 1.5" Standing Seam Profiles (Trim First)



Metal Roofing, Siding, and Trim
 P: 208-565-3002
 www.ibexmetal.com
 info@ibexmetal.com
 280 Great Northern Road
 Bonners Ferry, ID 83805

PROPERTY OF IBEX
 NOT FOR REPRODUCTION WITHOUT PRIOR
 WRITTEN CONSENT OF IBEX METAL, LLC

1

2

3

FRACTIONS ROUNDED TO NEAREST 1/16"
REVISED: 4/18/23

29 | 26 | 24 | 22

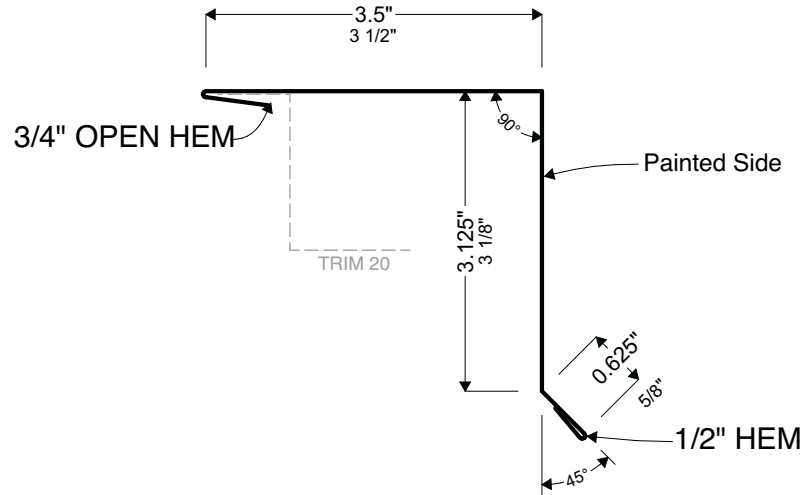

ARCHITECTURAL SERIES

A1 Profile Section Detail
Scale: 6" = 1'-0"

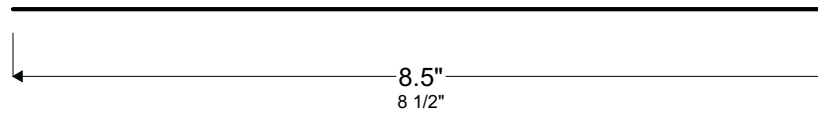

B1 Profile Flat Width Required
Scale: 6" = 1'-0"

TRIM 22 PROPERTY OF IBEX NOT FOR REPRODUCTION WITHOUT PRIOR WRITTEN CONSENT OF IBEX METAL, LLC	TRIM 22
---	----------------

Product ID :	22
Name :	ARCH'L RAKE/GABLE
Description :	Rake/Gable End Trim for Standing Seam Profiles



Metal Roofing, Siding, and Trim
 P: 208-565-3002
 www.ibexmetal.com
 info@ibexmetal.com
 280 Great Northern Road
 Bonners Ferry, ID 83805

1

2

3

FRACTIONS ROUNDED TO NEAREST 1/16"
REVISED: 4/18/23

29 | 26 | 24 | 22

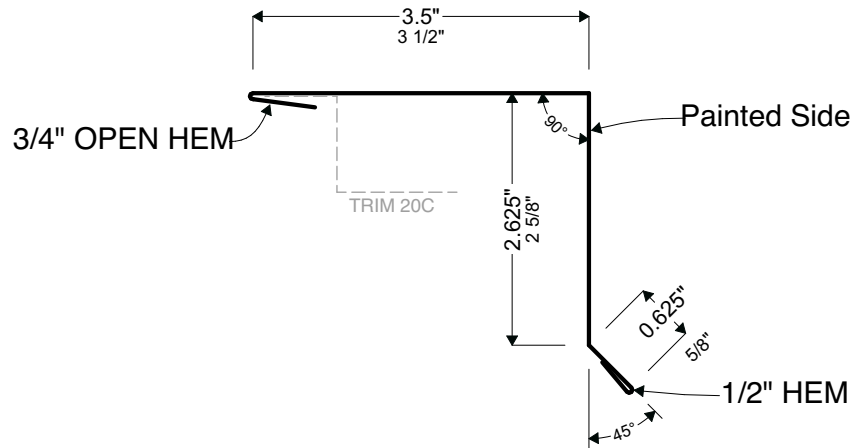

ARCHITECTURAL SERIES

A1 Profile Section Detail
Scale: 6" = 1'-0"

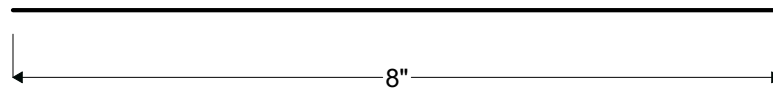

B1 Profile Flat Width Required
Scale: 6" = 1'-0"

PROPERTY OF IBEX NOT FOR REPRODUCTION WITHOUT PRIOR WRITTEN CONSENT OF IBEX METAL, LLC TRIM 22C	TRIM 22C

Product ID :	22C
Name :	MINI ARCH'L RAKE/GABLE
Description :	Smaller Rake/Gable Flashing for Standing Seam Profiles



Metal Roofing, Siding, and Trim
 P: 208-565-3002
 www.ibexmetal.com
 info@ibexmetal.com
 280 Great Northern Road
 Bonners Ferry, ID 83805

1

2

3

FRACTIONS ROUNDED TO NEAREST 1/16"
REVISED: 12/15/23

29 | 26 | 24 | 22

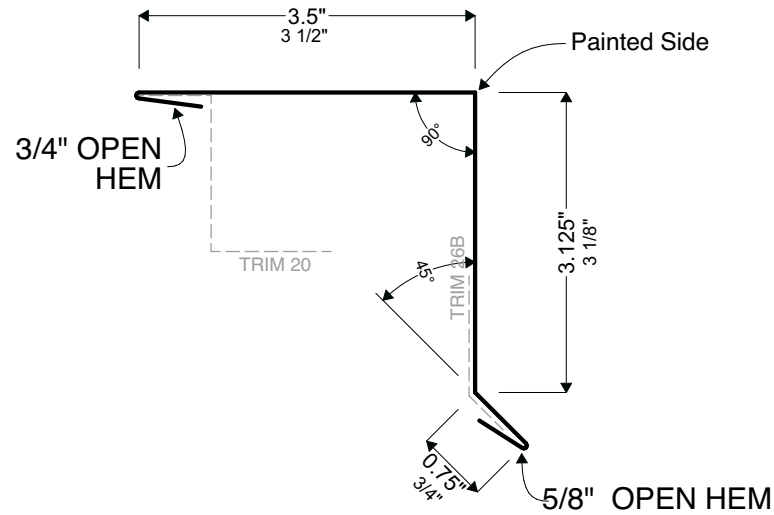

ARCHITECTURAL SERIES

A1 Profile Section Detail
Scale: 6" = 1'-0"

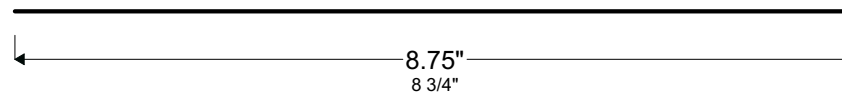

B1 Profile Flat Width Required
Scale: 6" = 1'-0"

TRIM 22D	PROPERTY OF IBEX NOT FOR REPRODUCTION WITHOUT PRIOR WRITTEN CONSENT OF IBEX METAL, LLC
-----------------	---

<i>Product ID :</i>	22D
<i>Name :</i>	3 PC ARCH'L RAKE/GABLE
<i>Description :</i>	3-Piece Rake/Gable Trim Designed to Fully Conceal Fasteners



Metal Roofing, Siding, and Trim
 P: 208-565-3002
 www.ibexmetal.com
 info@ibexmetal.com
 280 Great Northern Road
 Bonners Ferry, ID 83805

FRACTIONS ROUNDED TO NEAREST 1/16"
 REVISED: 4/5/23

29 | 26 | 24 | 22

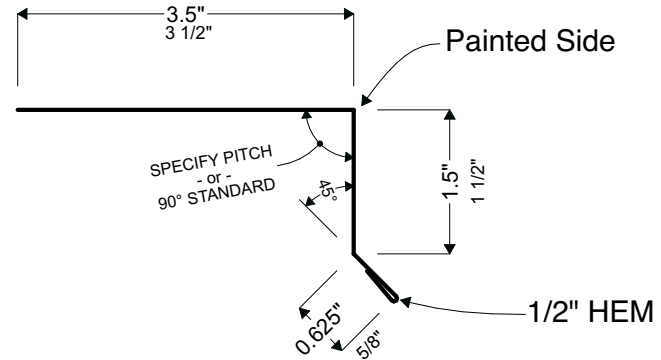
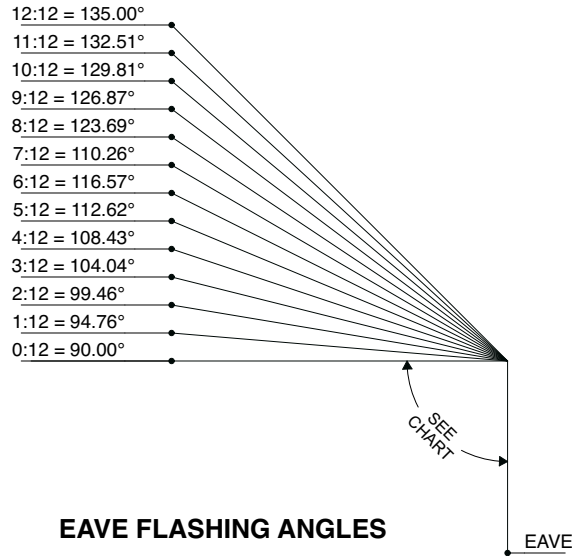

ARCHITECTURAL SERIES

A1 Profile Section Detail
 Scale: 6" = 1'-0"

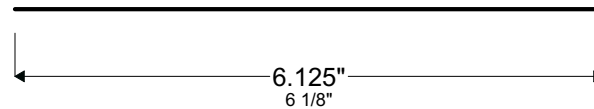

B1 Profile Flat Width Required
 Scale: 6" = 1'-0"

TRIM 23	PROPERTY OF IBEX NOT FOR REPRODUCTION WITHOUT PRIOR WRITTEN PERMISSION OF IBEX METAL, LLC
----------------	---

<i>Product ID :</i>	23
<i>Name :</i>	CONCEALED EAVE TRIM
<i>Description :</i>	Architectural Eave Trim (Specify Angle)



Metal Roofing, Siding, and Trim
 P: 208-565-3002
 www.ibexmetal.com
 info@ibexmetal.com
 280 Great Northern Road
 Bonners Ferry, ID 83805

FRACTIONS ROUNDED TO NEAREST 1/16"
 REVISED: 4/5/23

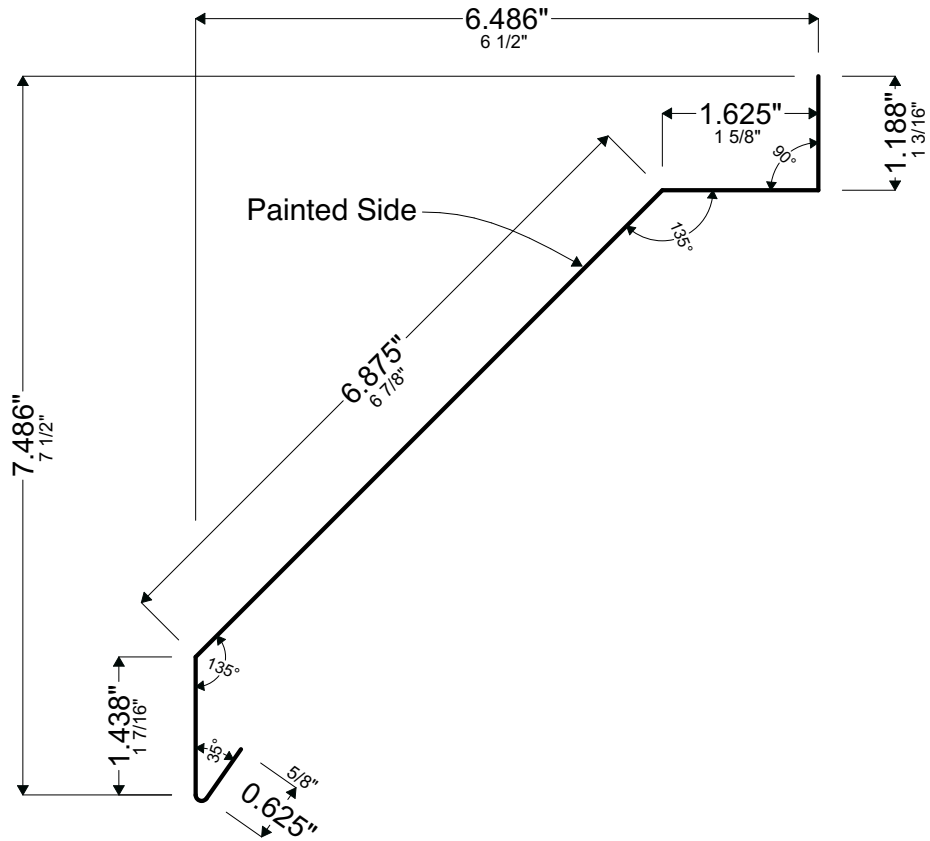

A1 Profile Section Detail
 Scale: 6" = 1'-0"

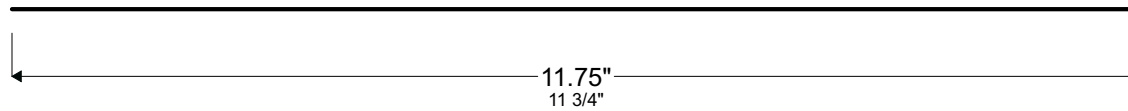

B1 Profile Flat Width Required
 Scale: 6" = 1'-0"

TRIM 24
PROPERTY OF IBEX
 NOT FOR REPRODUCTION WITHOUT PRIOR
 WRITTEN CONSENT OF IBEX METAL, LLC

Product ID :	24
Name :	TRACK COVER
Description :	Cannonball track cover



Metal Roofing, Siding, and Trim
 P: 208-565-3002
 www.ibexmetal.com
 info@ibexmetal.com
 280 Great Northern Road
 Bonners Ferry, ID 83805

1

2

3

FRACTIONS ROUNDED TO NEAREST 1/16"
REVISED: 4/5/23

29 | 26 | 24 | 22

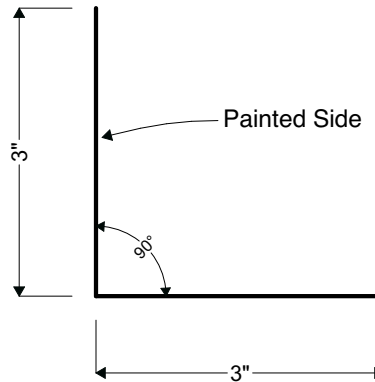

A **A1** Profile Section Detail
Scale: 6" = 1'-0"

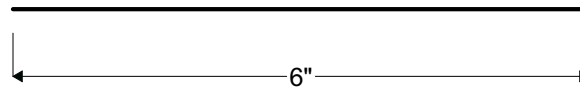

B **B1** Profile Flat Width Required
Scale: 6" = 1'-0"

TRIM 25

PROPERTY OF IBEX
NOT FOR REPRODUCTION WITHOUT PRIOR
WRITTEN CONSENT OF IBEX METAL, LLC

<i>Product ID :</i>	25
<i>Name :</i>	UNIVERSAL FLASHING
<i>Description :</i>	For Whatever You Need

IBEX

IDAHO'S BEST EXTERIORS

Metal Roofing, Siding, and Trim
P: 208-565-3002
www.ibexmetal.com
info@ibexmetal.com
280 Great Northern Road
Bonners Ferry, ID 83805

1

2

3

FRACTIONS ROUNDED TO NEAREST 1/16"
REVISED: 4/5/23

29 | 26 | 24 | 22

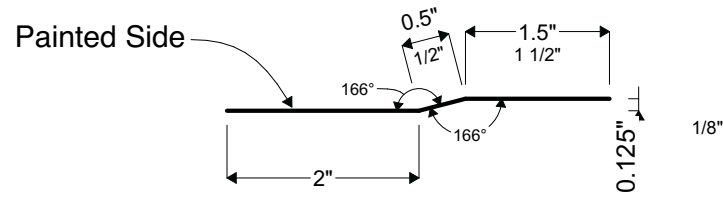

ARCHITECTURAL SERIES

A1 Profile Section Detail
Scale: 6" = 1'-0"

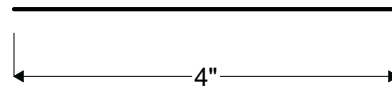

B1 Profile Flat Width Required
Scale: 6" = 1'-0"

TRIM 26

PROPERTY OF IBEX
NOT FOR REPRODUCTION WITHOUT PRIOR
WRITTEN CONSENT OF IBEX METAL, LLC

TRIM 26

<i>Product ID :</i>	26
<i>Name :</i>	OFFSET CLEAT
<i>Description :</i>	Used as Concealed Fastener



Metal Roofing, Siding, and Trim
 P: 208-565-3002
 www.ibexmetal.com
 info@ibexmetal.com
 280 Great Northern Road
 Bonners Ferry, ID 83805

1

2

3

FRACTIONS ROUNDED TO NEAREST 1/16"
REVISED: 12/12/23

29 | 26 | 24 | 22

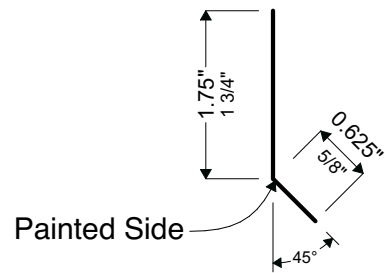

ARCHITECTURAL SERIES

A1 Profile Section Detail
Scale: 6" = 1'-0"

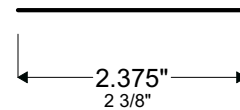

B1 Profile Flat Width Required
Scale: 6" = 1'-0"

TRIM 26B

PROPERTY OF IBEX
NOT FOR REPRODUCTION WITHOUT PRIOR
WRITTEN CONSENT OF IBEX METAL, LLC

TRIM 26B

<i>Product ID :</i>	26B
<i>Name :</i>	CLEAT
<i>Description :</i>	Used as Concealed Fastener



Metal Roofing, Siding, and Trim
 P: 208-565-3002
 www.ibexmetal.com
 info@ibexmetal.com
 280 Great Northern Road
 Bonners Ferry, ID 83805

1

2

3

FRACTIONS ROUNDED TO NEAREST 1/16"
REVISED: *Work in Progress*

29 | 26 | 24 | 22

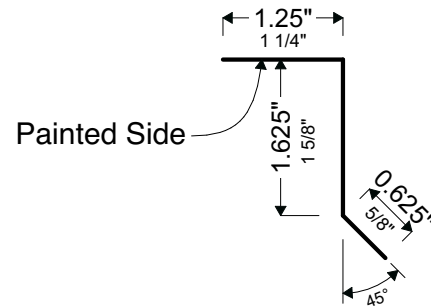

A

A1 Profile Section Detail
Scale: 6" = 1'-0"

A

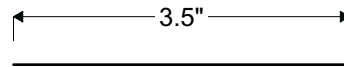

B

B1 Profile Flat Width Required
Scale: 6" = 1'-0"

B

TRIM 26C

PROPERTY OF IBEX
NOT FOR REPRODUCTION WITHOUT PRIOR
WRITTEN CONSENT OF IBEX METAL, LLC

TRIM 26C

Product ID : 26C

Name : **GABLE CLEAT**

Description : Used as Concealed Fastener



Metal Roofing, Siding, and Trim

P: 208-565-3002
www.ibexmetal.com
info@ibexmetal.com

280 Great Northern Road
Bonners Ferry, ID 83805

1

2

3

FRACTIONS ROUNDED TO NEAREST 1/16"
REVISED: 4/5/23

29 | 26 | 24

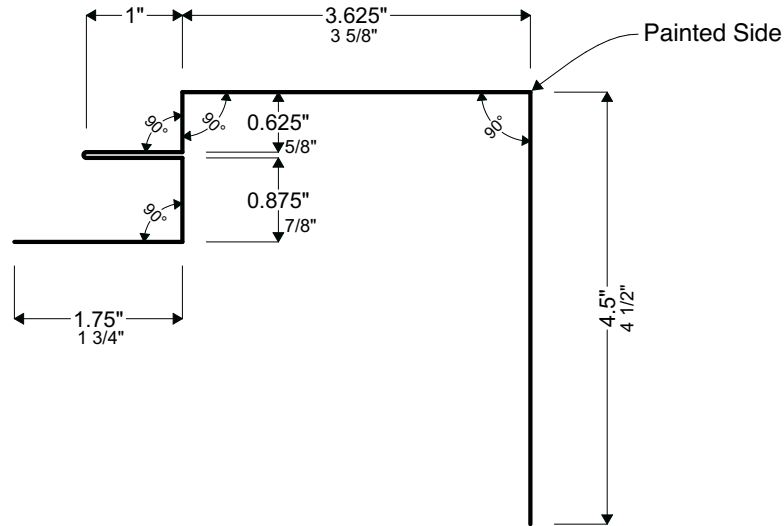

ARCHITECTURAL SERIES

A1 Profile Section Detail
Scale: 6" = 1'-0"

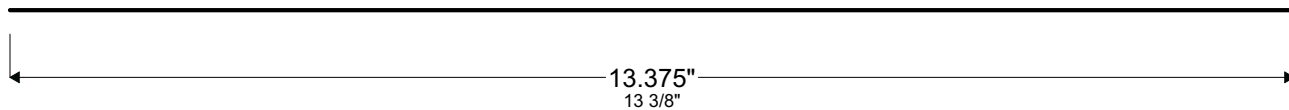

B1 Profile Flat Width Required
Scale: 6" = 1'-0"

TRIM 27

<i>Product ID :</i>	27
<i>Name :</i>	ARCHITECTURAL POST & DOOR TRIM
<i>Description :</i>	For Trimming around Doors & Windows



Metal Roofing, Siding, and Trim
 P: 208-565-3002
 www.ibexmetal.com
 info@ibexmetal.com
 280 Great Northern Road
 Bonners Ferry, ID 83805

TRIM 27

PROPERTY OF IBEX
NOT FOR REPRODUCTION WITHOUT PRIOR
WRITTEN CONSENT OF IBEX METAL, LLC

1

2

3

FRACTIONS ROUNDED TO NEAREST 1/16"
REVISED: 4/5/23

29 | 26 | 24

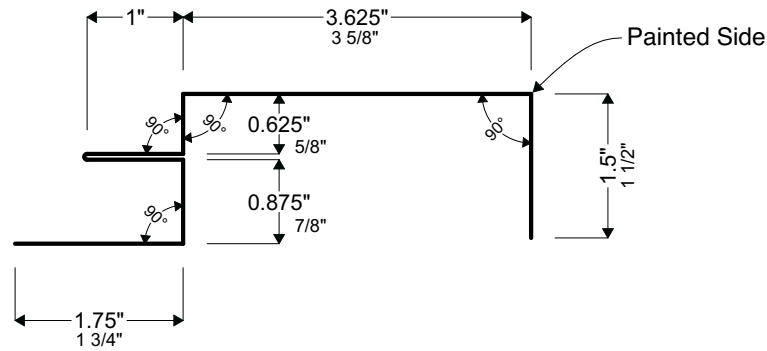

ARCHITECTURAL SERIES

A1 Profile Section Detail
Scale: 6" = 1'-0"

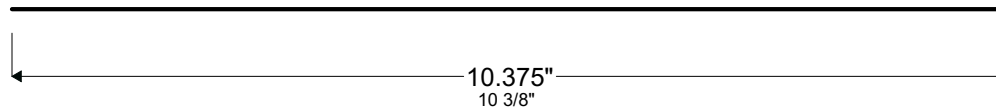

B1 Profile Flat Width Required
Scale: 6" = 1'-0"

TRIM 28

PROPERTY OF IBEX
NOT FOR REPRODUCTION WITHOUT PRIOR
WRITTEN CONSENT OF IBEX METAL, LLC

TRIM 28

Product ID :	28
Name :	ARCHITECTURAL TRIM
Description :	For Trimming around Doors & Windows



Metal Roofing, Siding, and Trim
 P: 208-565-3002
 www.ibexmetal.com
 info@ibexmetal.com
 280 Great Northern Road
 Bonners Ferry, ID 83805

1

2

3

FRACTIONS ROUNDED TO NEAREST 1/16"
REVISED: 12/12/23

29 | 26 | 24 | 22

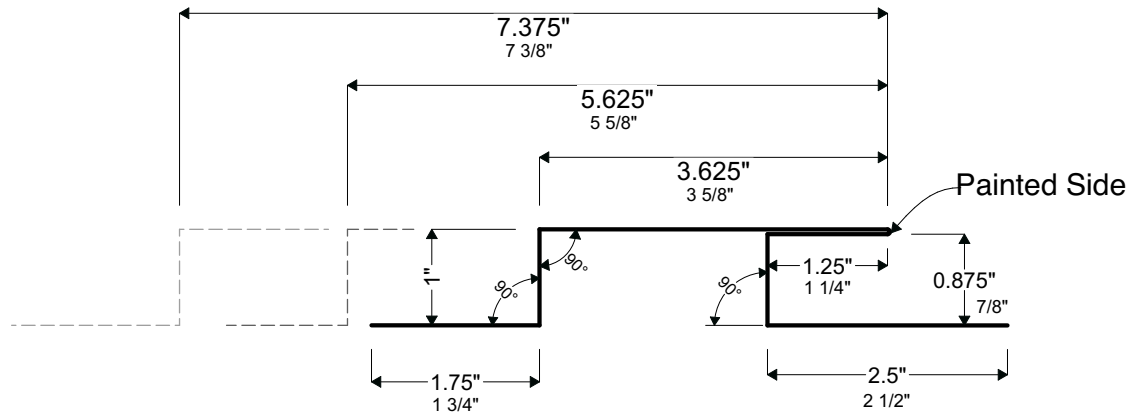

ARCHITECTURAL SERIES

A1 Profile Section Detail
Scale: 6" = 1'-0"

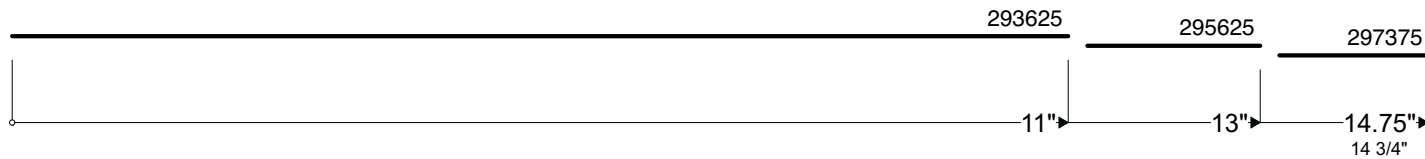

B1 Profile Flat Width Required
Scale: 6" = 1'-0"

TRIM 29

PROPERTY OF IBEX
NOT FOR REPRODUCTION WITHOUT PRIOR
WRITTEN CONSENT OF IBEX METAL, LLC

TRIM 29

<i>Product ID :</i>	293625, 295625, 297375
<i>Name :</i>	BOARD BAND
<i>Description :</i>	Larger Trim Band for Wainscoting



Metal Roofing, Siding, and Trim
 P: 208-565-3002
 www.ibexmetal.com
 info@ibexmetal.com
 280 Great Northern Road
 Bonners Ferry, ID 83805

1

2

3

FRACTIONS ROUNDED TO NEAREST 1/16"
REVISED: 12/12/23

29 | 26 | 24 | 22

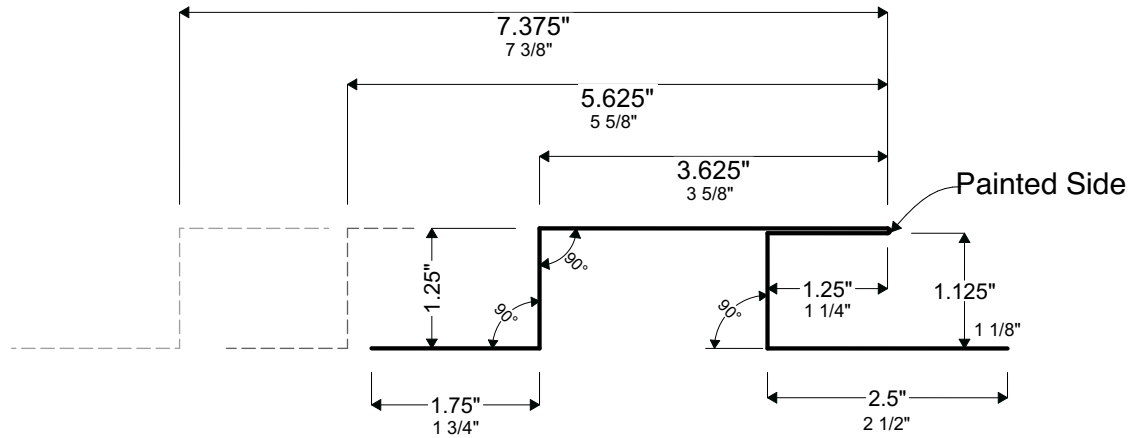

ARCHITECTURAL SERIES

A1 Profile Section Detail
Scale: 6" = 1'-0"

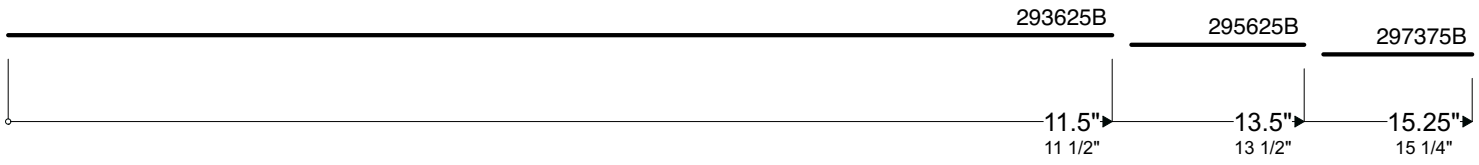

B1 Profile Flat Width Required
Scale: 6" = 1'-0"

TRIM 29B <small>PROPERTY OF IBEX NOT FOR REPRODUCTION WITHOUT PRIOR WRITTEN PERMISSION OF IBEX METAL, LLC</small>	TRIM 29B

<i>Product ID :</i>	293625B, 295625B, 297375B
<i>Name :</i>	BOARD BAND (1" RIB)
<i>Description :</i>	Larger Trim Band for 1" Rib Wainscoting



Metal Roofing, Siding, and Trim
 P: 208-565-3002
 www.ibexmetal.com
 info@ibexmetal.com
 280 Great Northern Road
 Bonners Ferry, ID 83805

TRIM 29B

FRACTIONS ROUNDED TO NEAREST 1/16"
 REVISED: 12/12/23

29 | 26 | 24 | 22

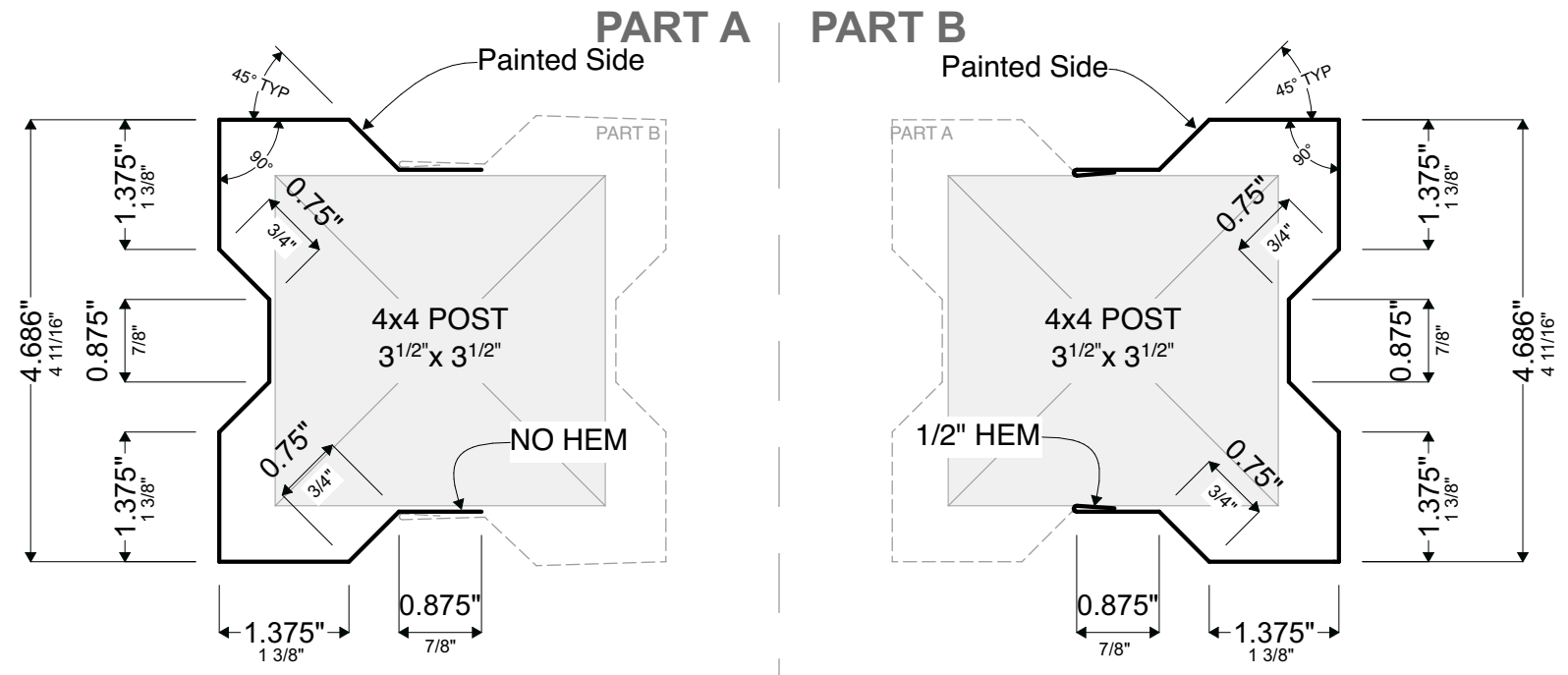

A1 Profile Section Detail
 Scale: 6" = 1'-0"

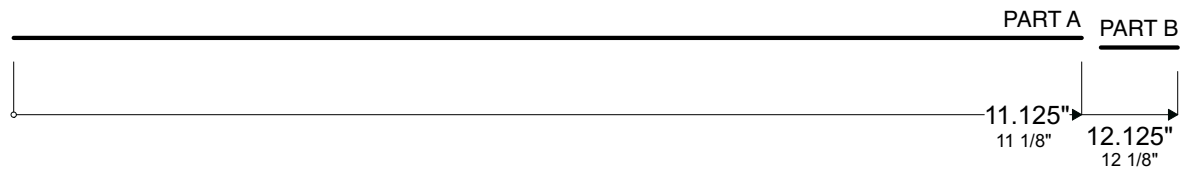

B1 Profile Flat Width Required
 Scale: 6" = 1'-0"

TRIM 304 PROPERTY OF IBEX NOT FOR REPRODUCTION WITHOUT PRIOR WRITTEN CONSENT OF IBEX METAL, LLC	TRIM 304	
	Product ID :	304A, 304B
	Name :	4x4 POST WRAP
Description :	2-Piece Full Post Wrap for 4x4	



Metal Roofing, Siding, and Trim

P: 208-565-3002
 www.ibexmetal.com
 info@ibexmetal.com

280 Great Northern Road
 Bonners Ferry, ID 83805

IDAHO'S BEST EXTERIORS

FRACTIONS ROUNDED TO NEAREST 1/16"
 REVISED: 12/12/23

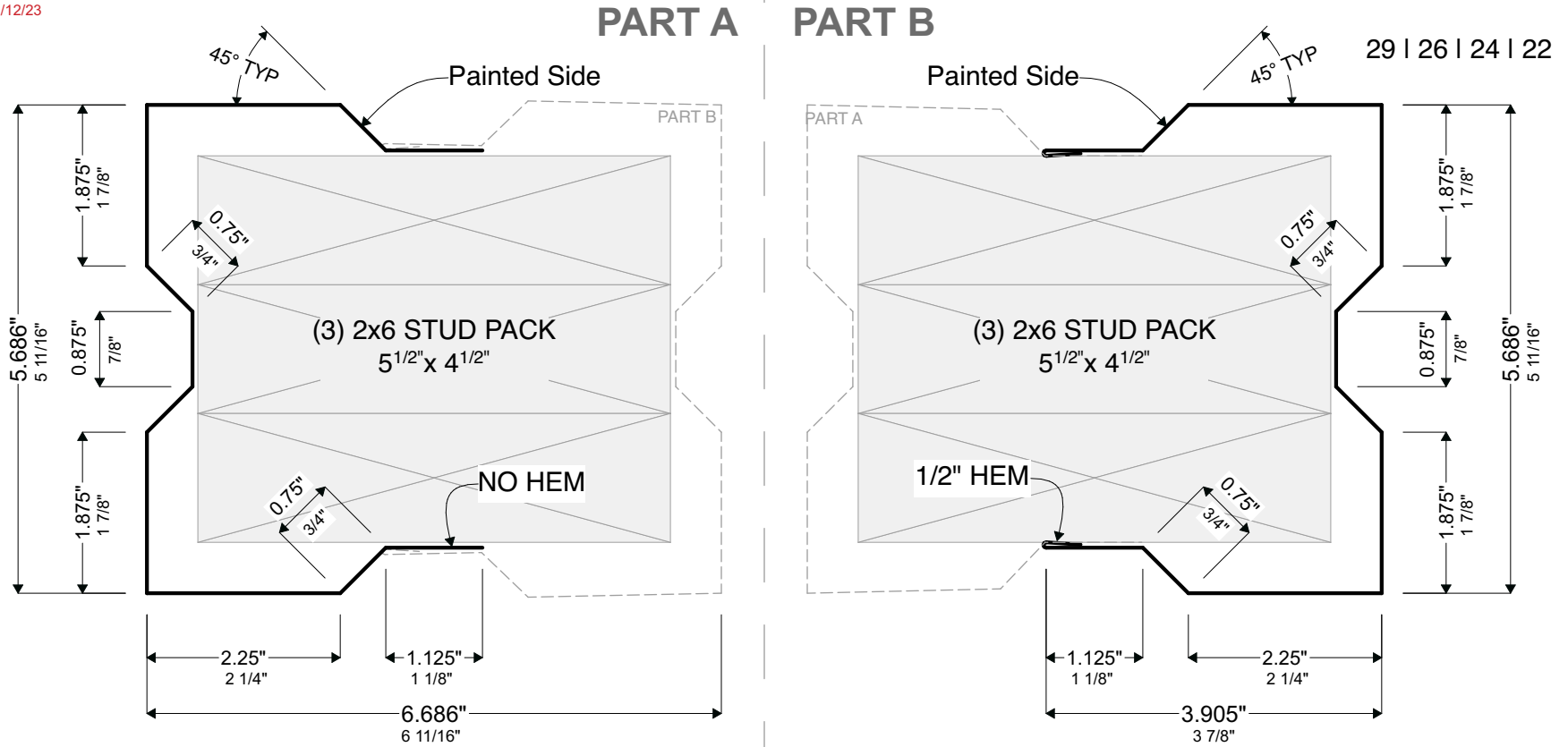

A1 Profile Section Detail
 Scale: 6" = 1'-0"

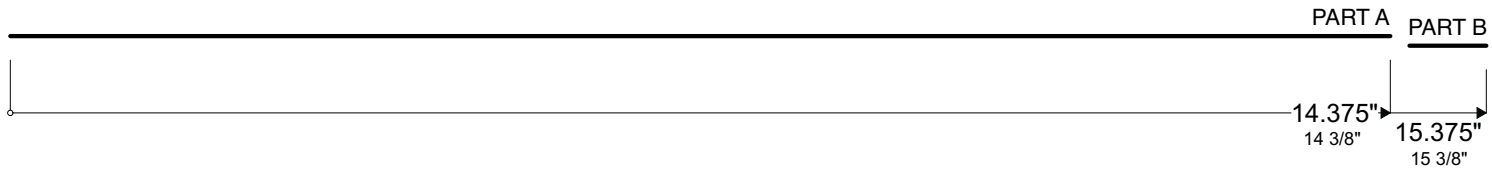

B1 Profile Flat Width Required
 Scale: 6" = 1'-0"

TRIM 305

PROPERTY OF IBEX
 NOT FOR REPRODUCTION WITHOUT PRIOR
 WRITTEN CONSENT OF IBEX METAL, LLC

TRIM 305

Product ID :	305A, 305B
Name :	(3) 2x6 STUD POST WRAP
Description :	2-Piece Full Post Wrap for Triple 2x6



Metal Roofing, Siding, and Trim
 P: 208-565-3002
 www.ibexmetal.com
 info@ibexmetal.com
 280 Great Northern Road
 Bonners Ferry, ID 83805

FRACTIONS ROUNDED TO NEAREST 1/16"
 REVISED: 12/12/23

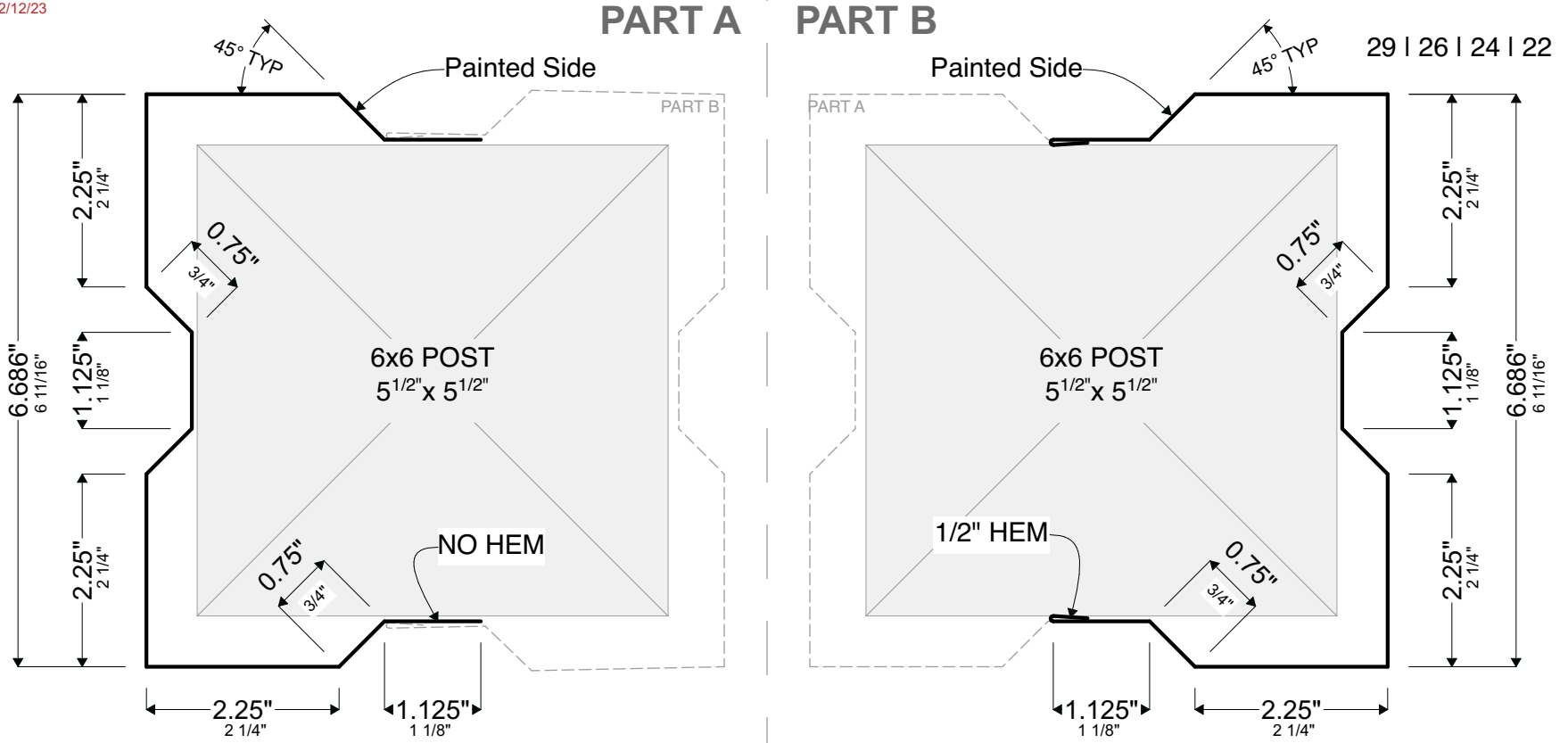

A1 Profile Section Detail
 Scale: 6" = 1'-0"

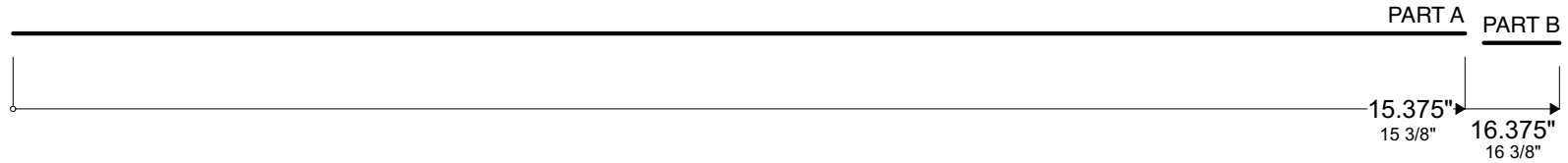

B1 Profile Flat Width Required
 Scale: 6" = 1'-0"

TRIM 306 PROPERTY OF IBEX NOT FOR REPRODUCTION WITHOUT PRIOR WRITTEN PERMISSION OF IBEX METAL, LLC	TRIM 306

Product ID :	306A, 306B
Name :	6x6 POST WRAP
Description :	2-Piece Full Post Wrap for 6x6



Metal Roofing, Siding, and Trim
 P: 208-565-3002
 www.ibexmetal.com
 info@ibexmetal.com
 280 Great Northern Road
 Bonners Ferry, ID 83805

FRACTIONS ROUNDED TO NEAREST 1/16"
 REVISED: 12/12/23

29 | 26 | 24 | 22

PEAK FLASHING ANGLES

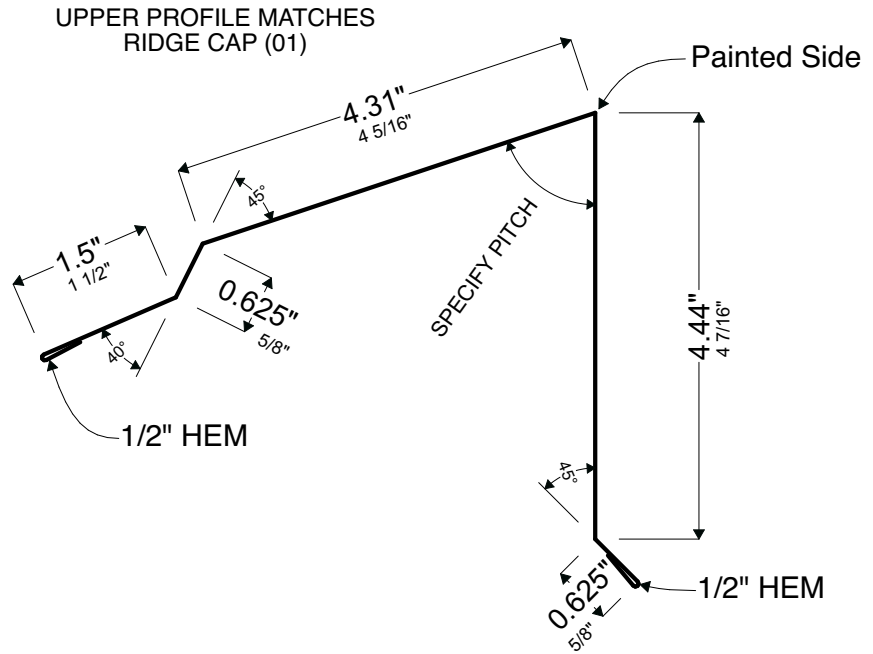
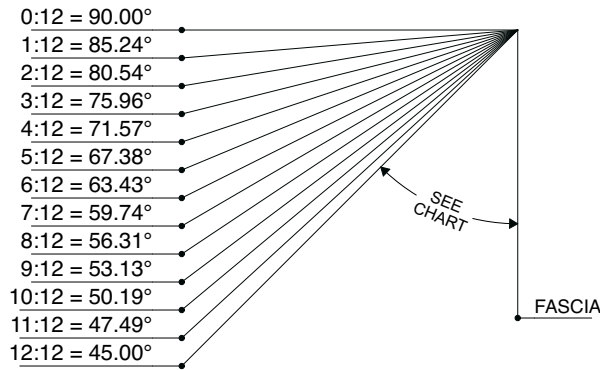

A1 Profile Section Detail
 Scale: 6" = 1'-0"

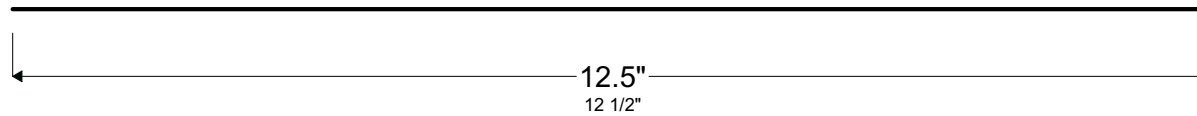

B1 Profile Flat Width Required
 Scale: 6" = 1'-0"

TRIM 31 PROPERTY OF IBEX NOT FOR REPRODUCTION WITHOUT PRIOR WRITTEN PERMISSION OF IBEX METAL, LLC	TRIM 31
--	---------

Product ID :	31
Name :	PEAK FLASHING
Description :	Upper Peak/Eave Flashing for Single Slope Roof



Metal Roofing, Siding, and Trim
 P: 208-565-3002
 www.ibexmetal.com
 info@ibexmetal.com
 280 Great Northern Road
 Bonners Ferry, ID 83805

FRACTIONS ROUNDED TO NEAREST 1/16"
 REVISED: 4/5/23

29 | 26 | 24 | 22

UPPER PROFILE MATCHES
 ARCH'L RIDGE CAP (01B)

PEAK FLASHING ANGLES

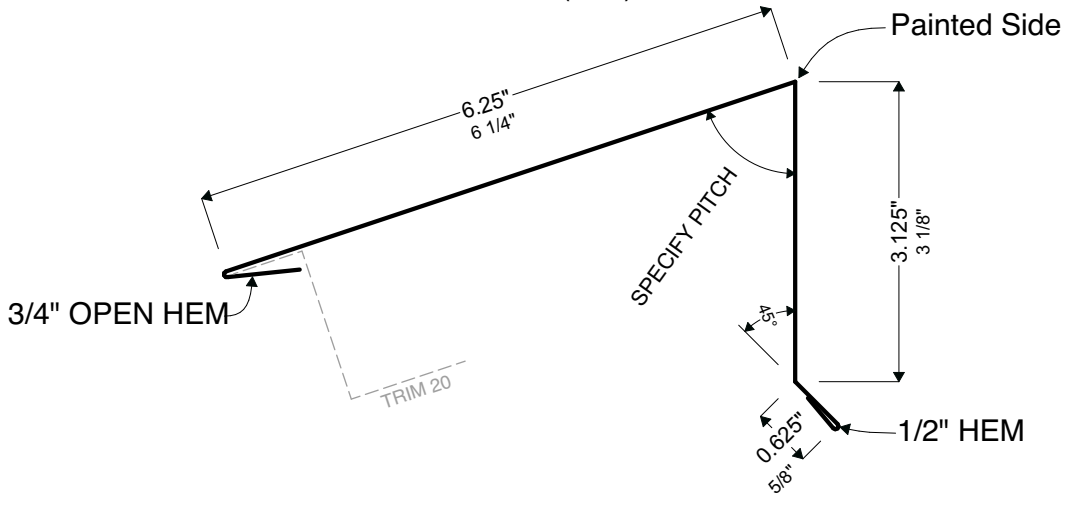
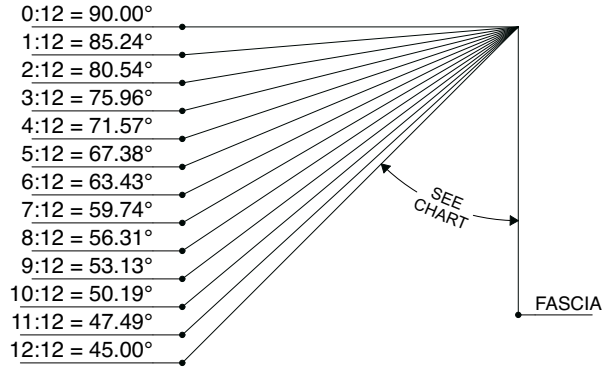

A1 Profile Section Detail
 Scale: 6" = 1'-0"

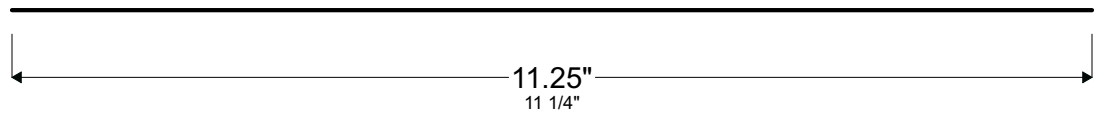

B1 Profile Flat Width Required
 Scale: 6" = 1'-0"

TRIM 31B

PROPERTY OF IBEX
 NOT FOR REPRODUCTION WITHOUT PRIOR
 WRITTEN CONSENT OF IBEX METAL, LLC

Product ID :	31B
Name :	ARCHITECTURAL PEAK FLASHING
Description :	Concealed Fastener Peak/Eave Flashing for Single Slope Roof

IBEX

IDAHO'S BEST EXTERIORS

Metal Roofing, Siding, and Trim
 P: 208-565-3002
 www.ibexmetal.com
 info@ibexmetal.com
 280 Great Northern Road
 Bonners Ferry, ID 83805

FRACTIONS ROUNDED TO NEAREST 1/16"
 REVISED: 4/5/23

UPPER PROFILE MATCHES
 ARCH'L RIDGE CAP (01B)

PEAK FLASHING ANGLES

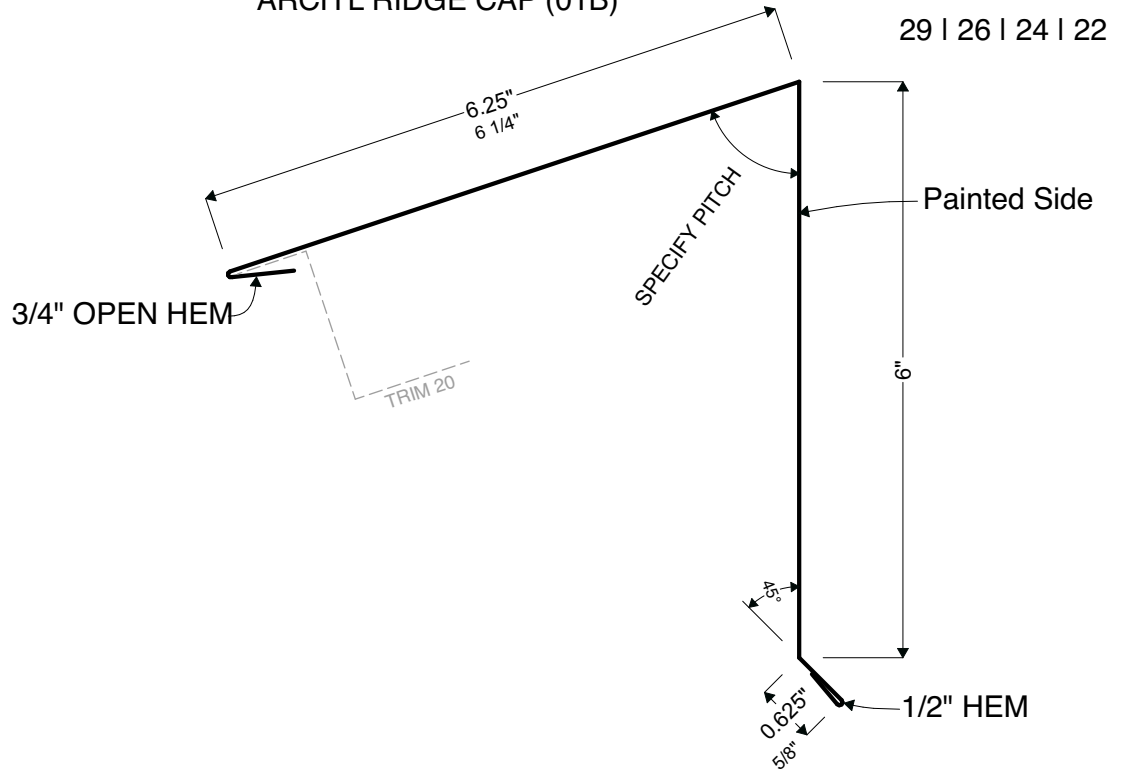
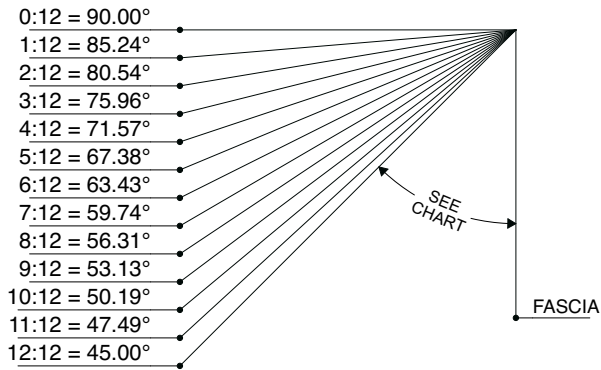

A1 Profile Section Detail
 Scale: 6" = 1'-0"

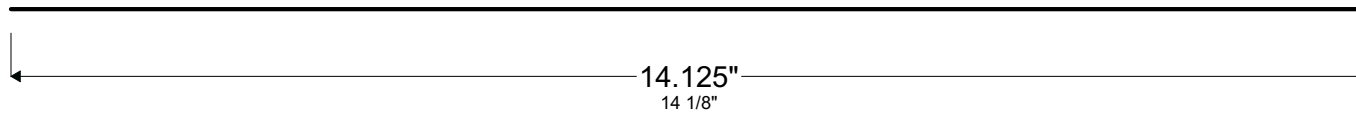

B1 Profile Flat Width Required
 Scale: 6" = 1'-0"

TRIM 31C

PROPERTY OF IBEX
 NOT FOR REPRODUCTION WITHOUT PRIOR
 WRITTEN CONSENT OF IBEX METAL, LLC

TRIM 31C

Product ID :	31C
Name :	JUMBO ARCH'L PEAK FLASHING
Description :	Jumbo Concealed Fastener Peak/Eave Flashing for Single Slope Roof

IBEX

IDAHO'S BEST EXTERIORS

Metal Roofing, Siding, and Trim

P: 208-565-3002
 www.ibexmetal.com
 info@ibexmetal.com

280 Great Northern Road
 Bonners Ferry, ID 83805

1

2

3

FRACTIONS ROUNDED TO NEAREST 1/16"
REVISED: *Work in Progress*

29 | 26 | 24 | 22

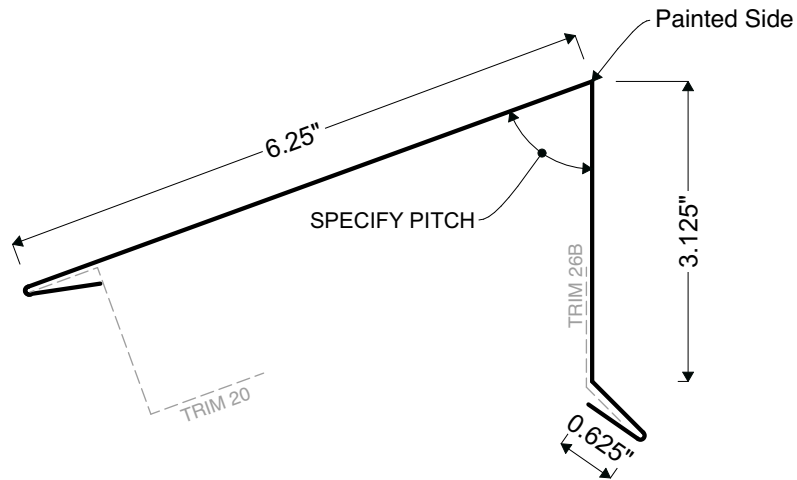

A **A1** Profile Section Detail
Scale: 6" = 1'-0"

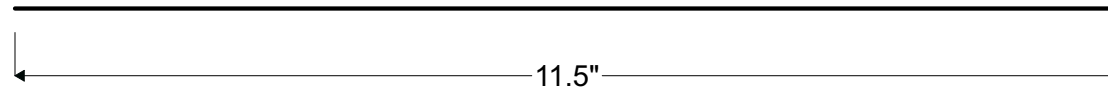

B **B1** Profile Flat Width Required
Scale: 6" = 1'-0"

TRIM 31D

PROPERTY OF IBEX
NOT FOR REPRODUCTION WITHOUT PRIOR
WRITTEN CONSENT OF IBEX METAL, LLC

<i>Product ID :</i>	31D
<i>Name :</i>	3 PC ARCH'L PEAK FLASHING
<i>Description :</i>	3-Piece Peak/Eave Flashing for Single Slope Roof Designed to Fully Conceal Fasteners



Metal Roofing, Siding, and Trim
 P: 208-565-3002
 www.ibexmetal.com
 info@ibexmetal.com
 280 Great Northern Road
 Bonners Ferry, ID 83805

FRACTIONS ROUNDED TO NEAREST 1/16"
 REVISED: 4/5/23

29 | 26 | 24 | 22

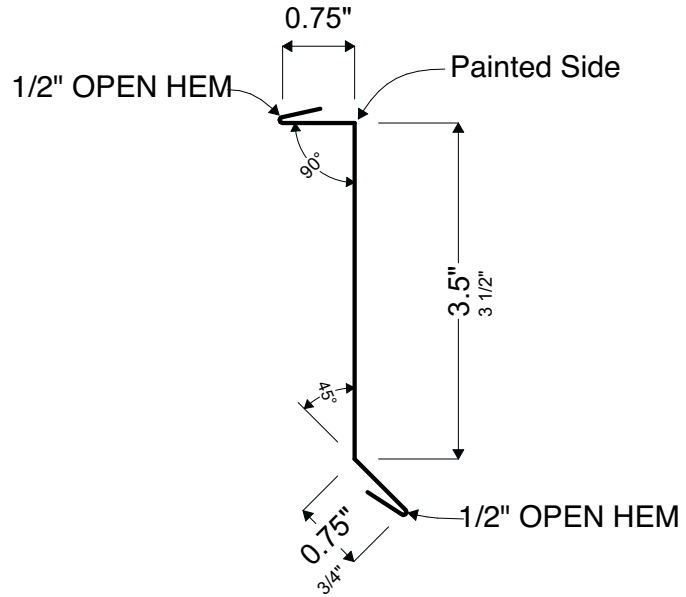

A **A1** Profile Section Detail
 Scale: 6" = 1'-0"

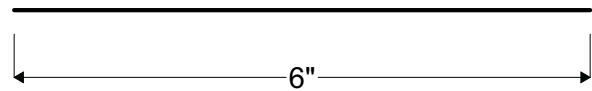

B **B1** Profile Flat Width Required
 Scale: 6" = 1'-0"

TRIM 32
PROPERTY OF IBEX
 NOT FOR REPRODUCTION WITHOUT PRIOR
 WRITTEN CONSENT OF IBEX METAL, LLC

<i>Product ID :</i>	32
<i>Name :</i>	REGLET FLASHING
<i>Description :</i>	Counter-Flashing for use w/Masonry Chimneys



IBEX

IDAHO'S BEST EXTERIORS

Metal Roofing, Siding, and Trim

P: 208-565-3002
 www.ibexmetal.com
 info@ibexmetal.com

280 Great Northern Road
 Bonners Ferry, ID 83805

FRACTIONS ROUNDED TO NEAREST 1/16"
REVISED: 12/12/23

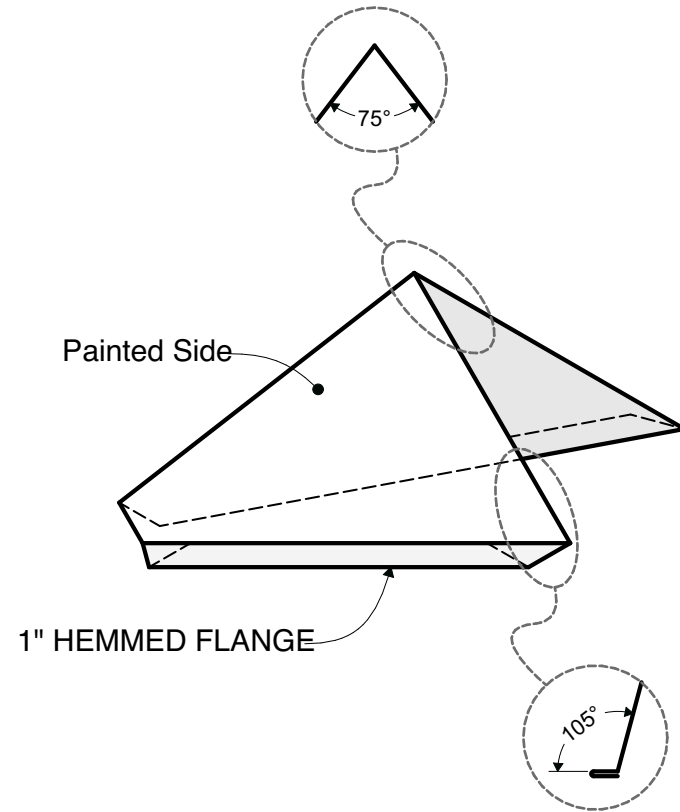
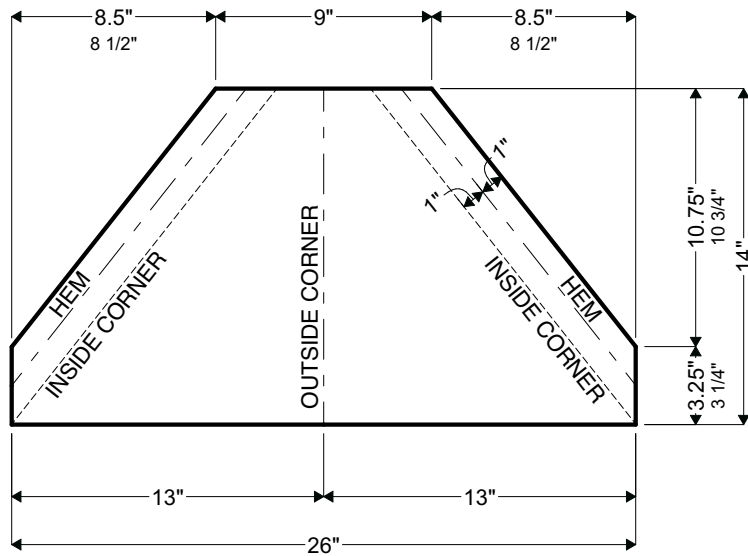

A1 Profile Section Detail
Scale: 1 1/2" = 1'-0"

TRIM 33 PROPERTY OF IBEX NOT FOR REPRODUCTION WITHOUT PRIOR WRITTEN CONSENT OF IBEX METAL, LLC	TRIM 33

Product ID :	33
Name :	SNOW DIVERTER
Description :	Snow Diverter



Metal Roofing, Siding, and Trim
 P: 208-565-3002
 www.ibexmetal.com
 info@ibexmetal.com
 280 Great Northern Road
 Bonners Ferry, ID 83805

1

2

3

FRACTIONS ROUNDED TO NEAREST 1/16"
REVISED: *Work in Progress*

29 | 26 | 24 | 22

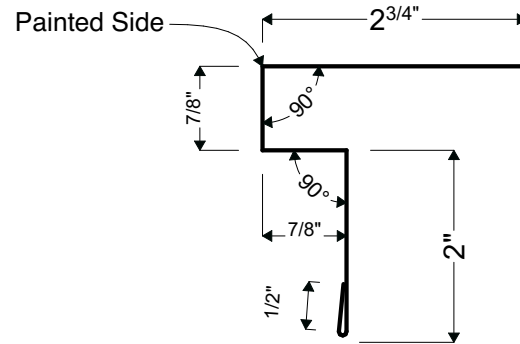

A	A1	Profile Section Detail Scale: 6" = 1'-0"	A
---	-----------	---	---

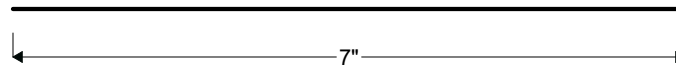

B	B1	Profile Flat Width Required Scale: 6" = 1'-0"	B
---	-----------	--	---

TRIM 34	TRIM 34	
----------------	----------------	--

PROPERTY OF IBEX
 NOT FOR REPRODUCTION WITHOUT PRIOR
 WRITTEN CONSENT OF IBEX METAL, LLC

<i>Product ID :</i>	34
<i>Name :</i>	SOFFIT TRIM
<i>Description :</i>	Soffit Trim for 3/4" Rib Siding & 3/4" Soffit

IDaho's BEST EXTERIORS

Metal Roofing, Siding, and Trim

P: 208-565-3002
www.ibexmetal.com
info@ibexmetal.com

280 Great Northern Road
 Bonners Ferry, ID 83805

1

2

3

FRACTIONS ROUNDED TO NEAREST 1/16"
REVISED: *Work in Progress*

29 | 26 | 24 | 22

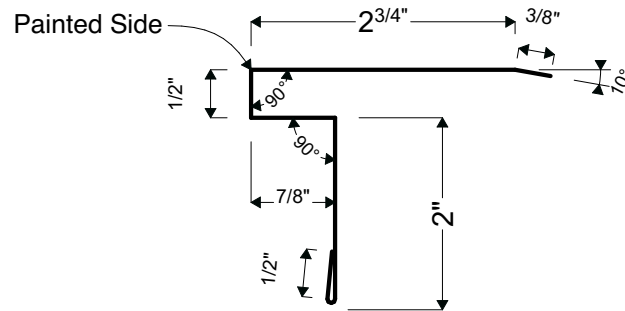

A1 Profile Section Detail
Scale: 6" = 1'-0"

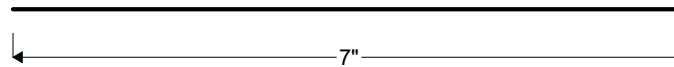

B1 Profile Flat Width Required
Scale: 6" = 1'-0"

TRIM 34B PROPERTY OF IBEX NOT FOR REPRODUCTION WITHOUT PRIOR WRITTEN CONSENT OF IBEX METAL, LLC	TRIM 34B

<i>Product ID :</i>	34B
<i>Name :</i>	MINI SOFFIT TRIM
<i>Description :</i>	Soffit Trim for 3/4" Rib Siding & Regular Soffit



Metal Roofing, Siding, and Trim
 P: 208-565-3002
 www.ibexmetal.com
 info@ibexmetal.com
 280 Great Northern Road
 Bonners Ferry, ID 83805

1

2

3

FRACTIONS ROUNDED TO NEAREST 1/16"
REVISED: *Work in Progress*

29 | 26 | 24 | 22

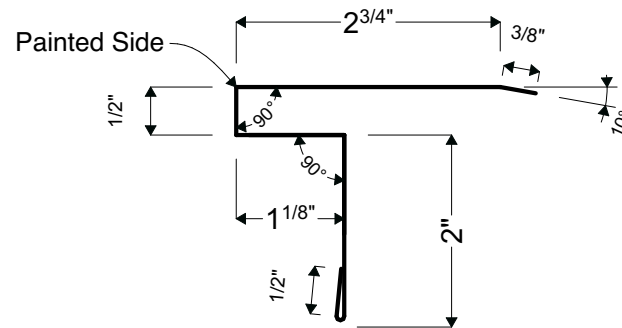

A **A1** Profile Section Detail
Scale: 6" = 1'-0"

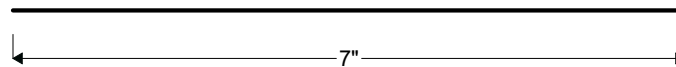

B **B1** Profile Flat Width Required
Scale: 6" = 1'-0"

TRIM 34C
PROPERTY OF IBEX
 NOT FOR REPRODUCTION WITHOUT PRIOR
 WRITTEN CONSENT OF IBEX METAL, LLC
TRIM 34C

<i>Product ID :</i>	34C
<i>Name :</i>	MINI SOFFIT TRIM (1" RIB)
<i>Description :</i>	Soffit Trim for 1" Rib Siding & Regular Soffit



IBEX

IDAHO'S BEST EXTERIORS

Metal Roofing, Siding, and Trim

P: 208-565-3002
www.ibexmetal.com
info@ibexmetal.com

280 Great Northern Road
 Bonners Ferry, ID 83805

1

2

3

FRACTIONS ROUNDED TO NEAREST 1/16"
REVISED: *Work in Progress*

29 | 26 | 24

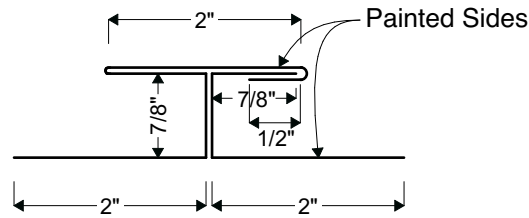

ARCHITECTURAL SERIES

A1 Profile Section Detail
Scale: 6" = 1'-0"

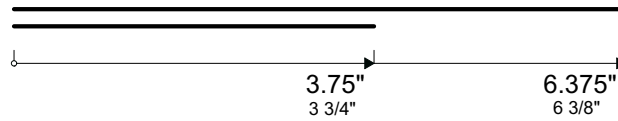

B1 Profile Flat Width Required
Scale: 6" = 1'-0"

TRIM 35

PROPERTY OF IBEX
NOT FOR REPRODUCTION WITHOUT PRIOR
WRITTEN CONSENT OF IBEX METAL, LLC

<i>Product ID :</i>	35
<i>Name :</i>	H CHANNEL
<i>Description :</i>	H Channel Trim



Metal Roofing, Siding, and Trim
 P: 208-565-3002
 www.ibexmetal.com
 info@ibexmetal.com
 280 Great Northern Road
 Bonners Ferry, ID 83805

1

2

3

FRACTIONS ROUNDED TO NEAREST 1/16"
REVISED: *Work in Progress*

29 | 26 | 24

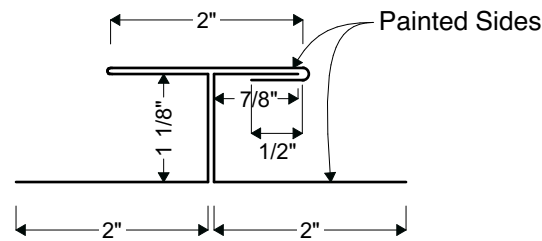

ARCHITECTURAL SERIES

A1 Profile Section Detail
Scale: 6" = 1'-0"

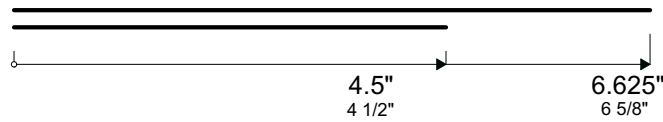

B1 Profile Flat Width Required
Scale: 6" = 1'-0"

TRIM 35B

PROPERTY OF IBEX
NOT FOR REPRODUCTION WITHOUT PRIOR
WRITTEN CONSENT OF IBEX METAL, LLC

TRIM 35B

<i>Product ID :</i>	35B
<i>Name :</i>	H CHANNEL (1" RIB)
<i>Description :</i>	H Channel Trim (1" Rib)



Metal Roofing, Siding, and Trim

P: 208-565-3002
www.ibexmetal.com
info@ibexmetal.com

280 Great Northern Road
Bonners Ferry, ID 83805

FRACTIONS ROUNDED TO NEAREST 1/16"
 REVISED: 4/5/23

26 | 24

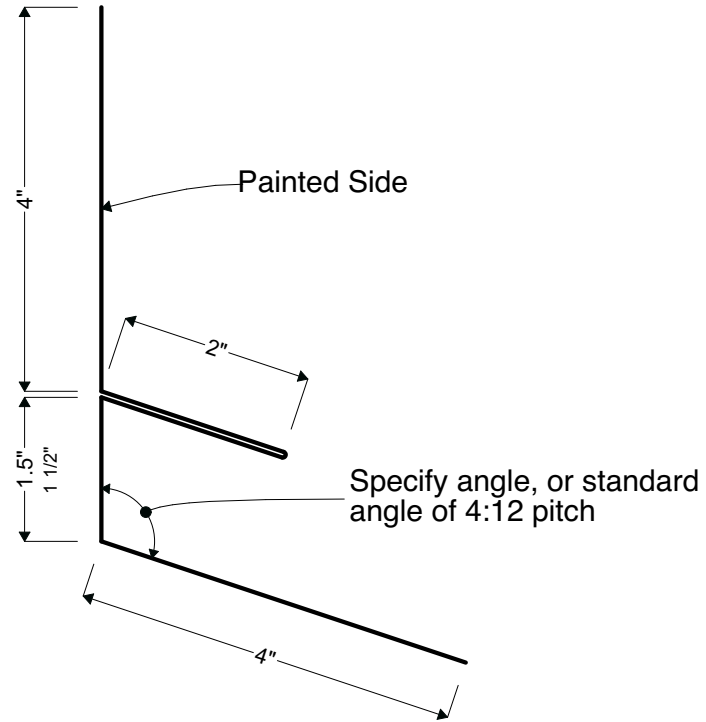
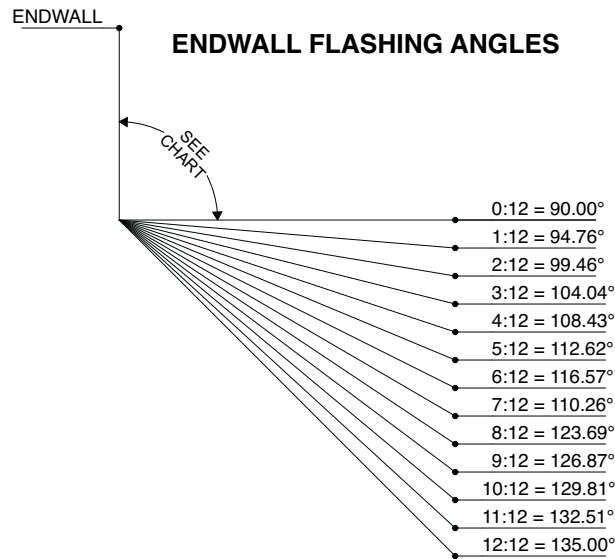

ARCHITECTURAL SERIES

A **A1** Profile Section Detail
 Scale: 6" = 1'-0"

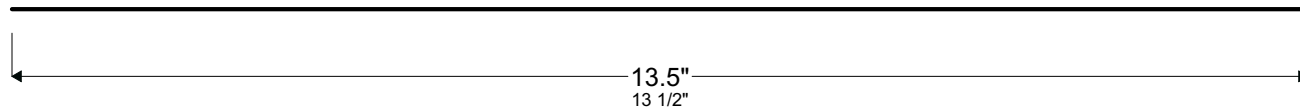

B **B1** Profile Flat Width Required
 Scale: 6" = 1'-0"

TRIM 50

PROPERTY OF IBEX
 NOT FOR REPRODUCTION WITHOUT PRIOR
 WRITTEN CONSENT OF IBEX METAL, LLC

TRIM 50

Product ID :	50
Name :	TRIM FIRST ENDWALL
Description :	Endwall Flashing for Concealed Fastener



Metal Roofing, Siding, and Trim
 P: 208-565-3002
 www.ibexmetal.com
 info@ibexmetal.com
 280 Great Northern Road
 Bonners Ferry, ID 83805

FRACTIONS ROUNDED TO NEAREST 1/16"
 REVISED: 7/18/23

26 | 24

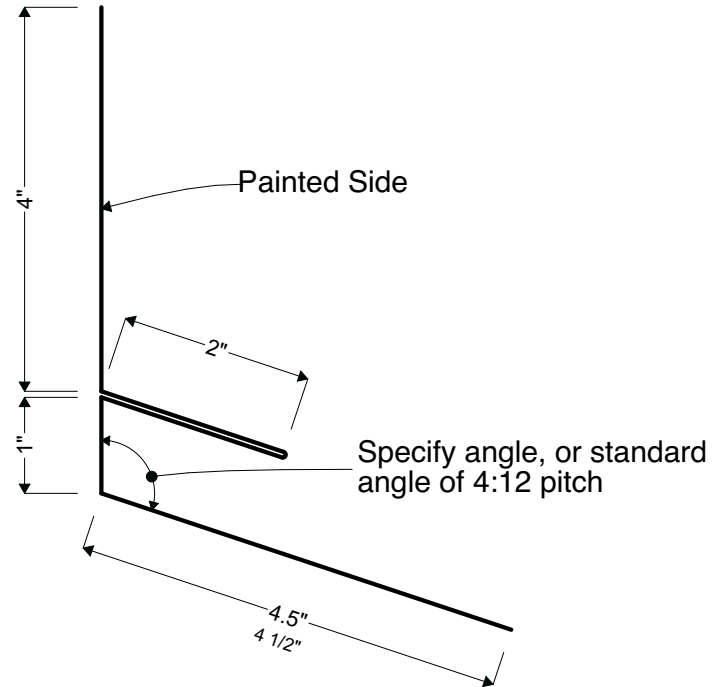
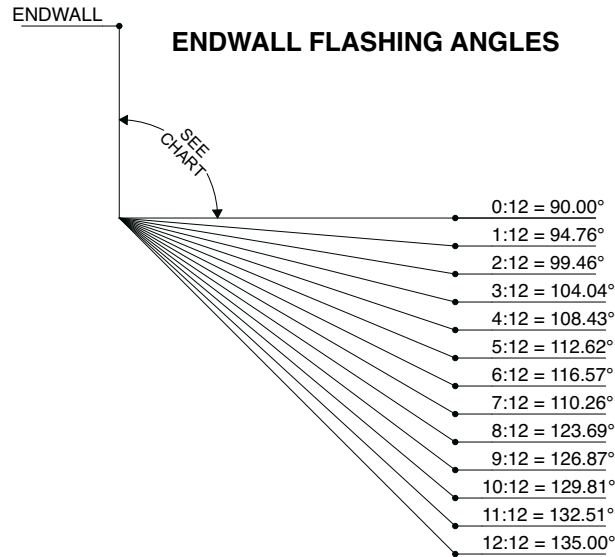

ARCHITECTURAL SERIES

A1 Profile Section Detail
 Scale: 6" = 1'-0"

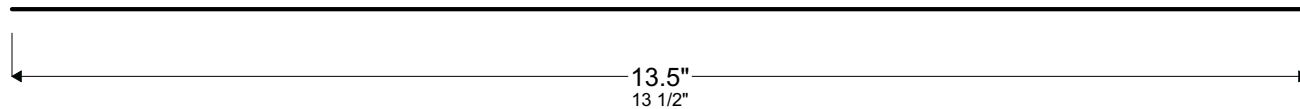

B1 Profile Flat Width Required
 Scale: 6" = 1'-0"

TRIM 50A

PROPERTY OF IBEX
 NOT FOR REPRODUCTION WITHOUT PRIOR
 WRITTEN CONSENT OF IBEX METAL, LLC

TRIM 50A

<i>Product ID :</i>	50A
<i>Name :</i>	TRIM FIRST ENDWALL (1" RIB)
<i>Description :</i>	Endwall Flashing for 1" Rib Panel Concealed Fastener

IBEX

IDAHO'S BEST EXTERIORS

Metal Roofing, Siding, and Trim
 P: 208-565-3002
 www.ibexmetal.com
 info@ibexmetal.com
 280 Great Northern Road
 Bonners Ferry, ID 83805

1

2

3

FRACTIONS ROUNDED TO NEAREST 1/16"
REVISED: 4/5/23

29 | 26 | 24 | 22

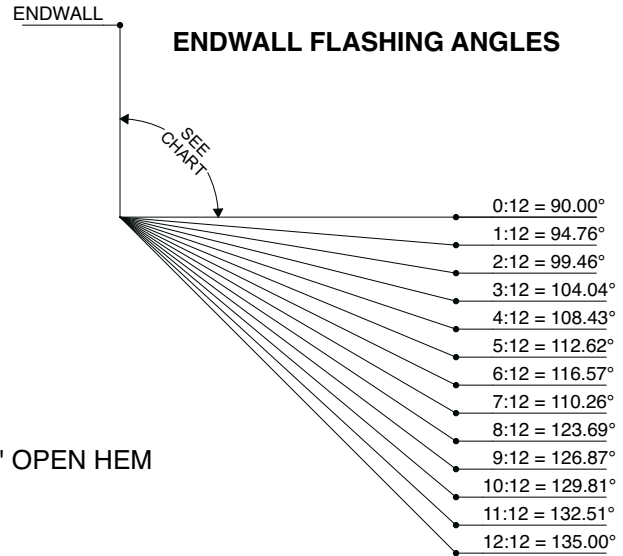
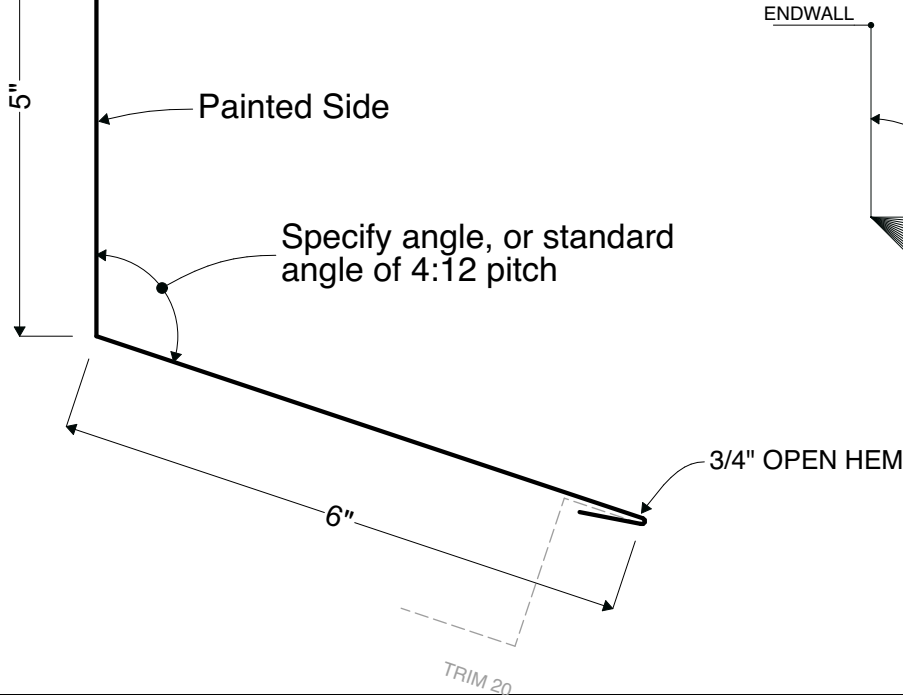

ARCHITECTURAL SERIES

A1 Profile Section Detail
Scale: 6" = 1'-0"

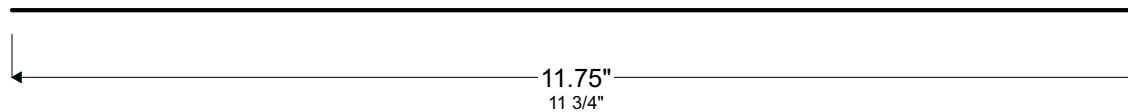

B1 Profile Flat Width Required
Scale: 6" = 1'-0"

TRIM 50B

PROPERTY OF IBEX
NOT FOR REPRODUCTION WITHOUT PRIOR WRITTEN CONSENT OF IBEX METAL, LLC

TRIM 50B

Product ID :	50B
Name :	STANDING SEAM ENDWALL
Description :	Endwall Flashing for Concealed Fastener



Metal Roofing, Siding, and Trim

P: 208-565-3002
www.ibexmetal.com
info@ibexmetal.com

280 Great Northern Road
Bonners Ferry, ID 83805

1 2 3

FRACTIONS ROUNDED TO NEAREST 1/16"
 REVISED: 4/5/23

29 | 26 | 24 | 22

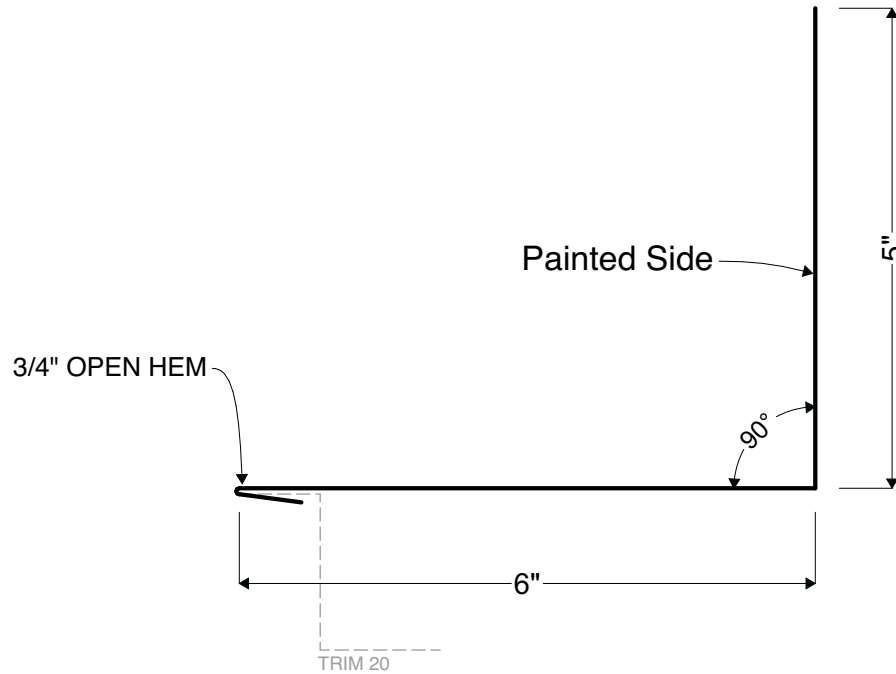

ARCHITECTURAL SERIES

A1 Profile Section Detail
 Scale: 6" = 1'-0"

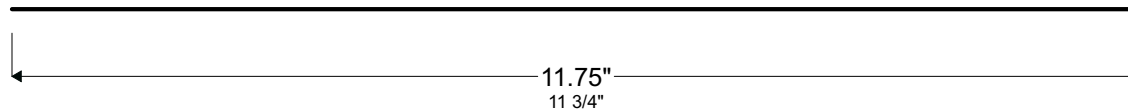

B1 Profile Flat Width Required
 Scale: 6" = 1'-0"

TRIM 50C

PROPERTY OF IBEX
 NOT FOR REPRODUCTION WITHOUT PRIOR
 WRITTEN CONSENT OF IBEX METAL, LLC

TRIM 50C

<i>Product ID :</i>	50C
<i>Name :</i>	STANDING SEAM SIDEWALL
<i>Description :</i>	Sidewall Flashing for Concealed Fastener



Metal Roofing, Siding, and Trim
 P: 208-565-3002
 www.ibexmetal.com
 info@ibexmetal.com
 280 Great Northern Road
 Bonners Ferry, ID 83805

FRACTIONS ROUNDED TO NEAREST 1/16"
 REVISED: *Work in Progress*

29 | 26 | 24 | 22

Painted Side

9.25"

Specify angle, or
 standard angle of 162°
 (12:12 to 6:12 transition)

3/4" OPEN HEM

10"

ARCHITECTURAL SERIES

A1 Profile Section Detail
 Scale: 6" = 1'-0"

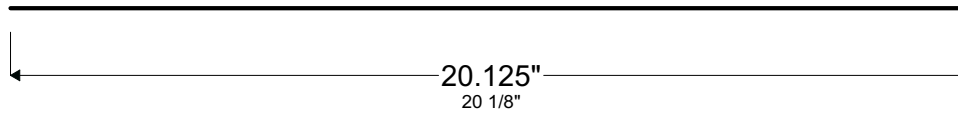

B1 Profile Flat Width Required
 Scale: 6" = 1'-0"

TRIM 50D

Product ID :	50D
Name :	STANDING SEAM PITCH BREAK
Description :	Pitch Break Transition for Concealed Fastener



Metal Roofing, Siding, and Trim
 P: 208-565-3002
 www.ibexmetal.com
 info@ibexmetal.com
 280 Great Northern Road
 Bonners Ferry, ID 83805

TRIM 50D

PROPERTY OF IBEX
 NOT FOR REPRODUCTION WITHOUT PRIOR
 WRITTEN PERMISSION OF IBEX METAL, LLC

1

2

3

FRACTIONS ROUNDED TO NEAREST 1/16"
REVISED: 4/5/23

29 | 26 | 24

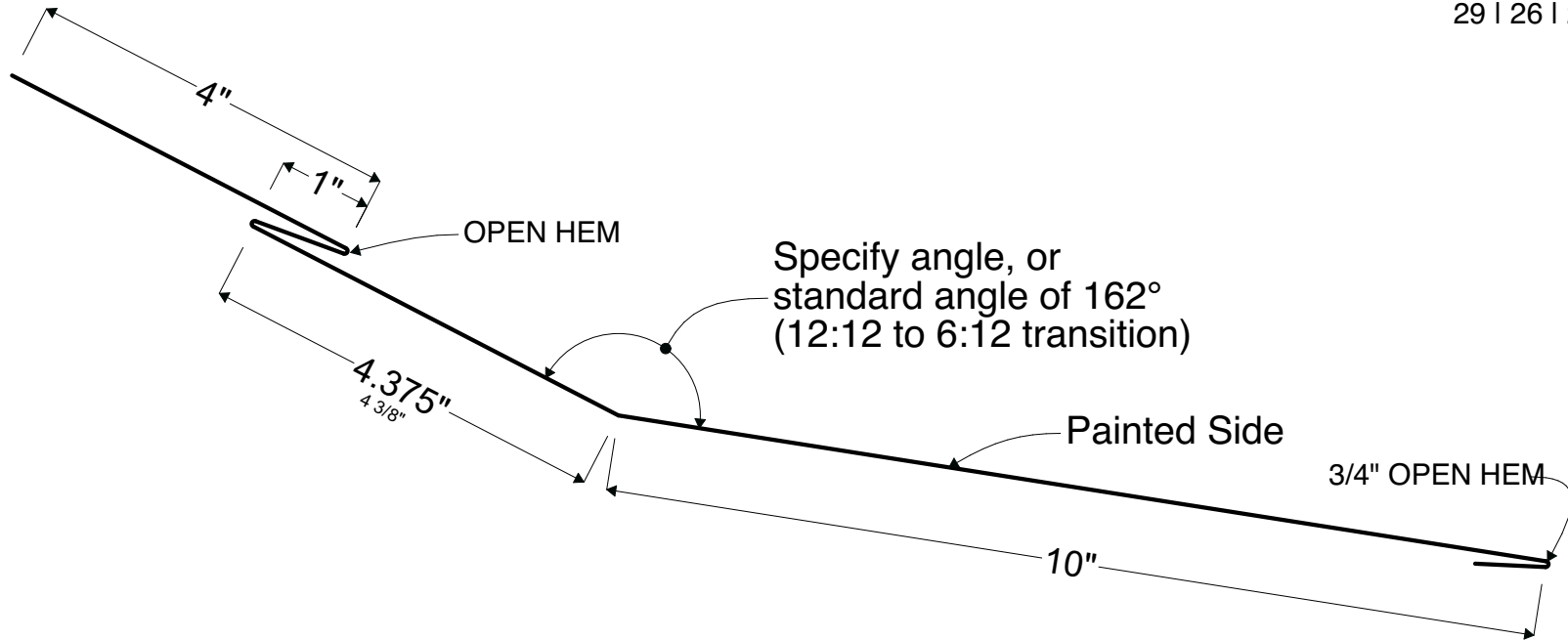

ARCHITECTURAL SERIES

A1 Profile Section Detail
Scale: 6" = 1'-0"

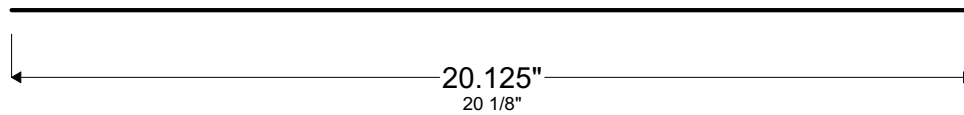

B1 Profile Flat Width Required
Scale: 3" = 1'-0"

TRIM 50E

PROPERTY OF IBEX
NOT FOR REPRODUCTION WITHOUT PRIOR
WRITTEN PERMISSION OF IBEX METAL, LLC

TRIM 50E

Product ID :	50E
Name :	CLEATED PITCH BREAK
Description :	Pitch Break Transition for Concealed Fastener



Metal Roofing, Siding, and Trim
 P: 208-565-3002
 www.ibexmetal.com
 info@ibexmetal.com
 280 Great Northern Road
 Bonners Ferry, ID 83805

1

2

3

FRACTIONS ROUNDED TO NEAREST 1/16"
REVISED: 12/12/23

29 | 26 | 24 | 22

10'-6"

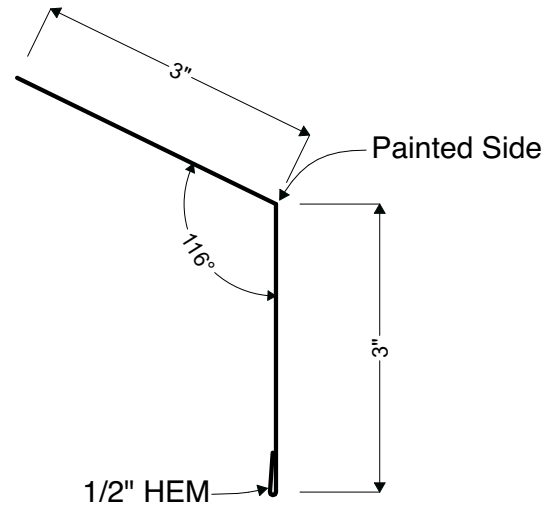

A **A1** Profile Section Detail
Scale: 6" = 1'-0"

A

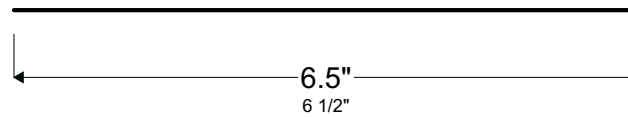

B **B1** Profile Flat Width Required
Scale: 6" = 1'-0"

B

TRIM 60 PROPERTY OF IBEX NOT FOR REPRODUCTION WITHOUT PRIOR WRITTEN CONSENT OF IBEX METAL, LLC	TRIM 60

Product ID :	60
Name :	PINE HILL EAVE/GAMBREL TRIM
Description :	Eave or Gambrel Flashing



Metal Roofing, Siding, and Trim
 P: 208-565-3002
 www.ibexmetal.com
 info@ibexmetal.com
 280 Great Northern Road
 Bonners Ferry, ID 83805

1

2

3

FRACTIONS ROUNDED TO NEAREST 1/16"
REVISED: 12/12/23

29 | 26 | 24 | 22

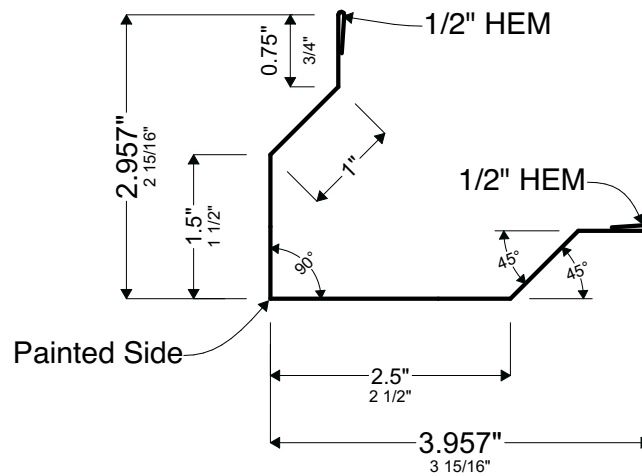

A1 Profile Section Detail
Scale: 6" = 1'-0"

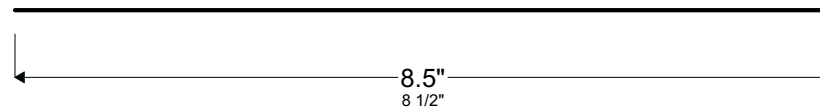

B1 Profile Flat Width Required
Scale: 6" = 1'-0"

TRIM 61 PROPERTY OF IBEX NOT FOR REPRODUCTION WITHOUT PRIOR WRITTEN CONSENT OF IBEX METAL, LLC	TRIM 61
---	----------------

Product ID :	61
Name :	PINE HILL OUTSIDE CORNER
Description :	Outside Corner Trim (Pine Hill)



Metal Roofing, Siding, and Trim
 P: 208-565-3002
 www.ibexmetal.com
 info@ibexmetal.com
 280 Great Northern Road
 Bonners Ferry, ID 83805

1

2

3

FRACTIONS ROUNDED TO NEAREST 1/16"
REVISED: 4/5/23

29 | 26 | 24 | 22

NO BENDS

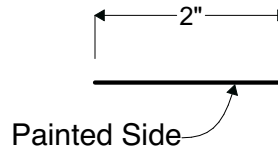

A

A1 Profile Section Detail
Scale: 6" = 1'-0"

A

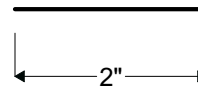

B

B1 Profile Flat Width Required
Scale: 6" = 1'-0"

B

PROPERTY OF IBEX
NOT FOR REPRODUCTION WITHOUT PRIOR
WRITTEN CONSENT OF IBEX METAL, LLC

TRIM 62

TRIM 62

Product ID : 62

Name : COLOR GUARD

Description : Color Guard Strip for "SS Color Guard"



Metal Roofing, Siding, and Trim

P: 208-565-3002
www.ibexmetal.com
info@ibexmetal.com

280 Great Northern Road
Bonners Ferry, ID 83805

FRACTIONS ROUNDED TO NEAREST 1/16"
 REVISED: 7/18/23

29 | 26 | 24 | 22

- 12:12 = 135.00°
- 11:12 = 132.51°
- 10:12 = 129.81°
- 9:12 = 126.87°
- 8:12 = 123.69°
- 7:12 = 110.26°
- 6:12 = 116.57°
- 5:12 = 112.62°
- 4:12 = 108.43°
- 3:12 = 104.04°
- 2:12 = 99.46°
- 1:12 = 94.76°
- 0:12 = 90.00°

EAVE FLASHING ANGLES

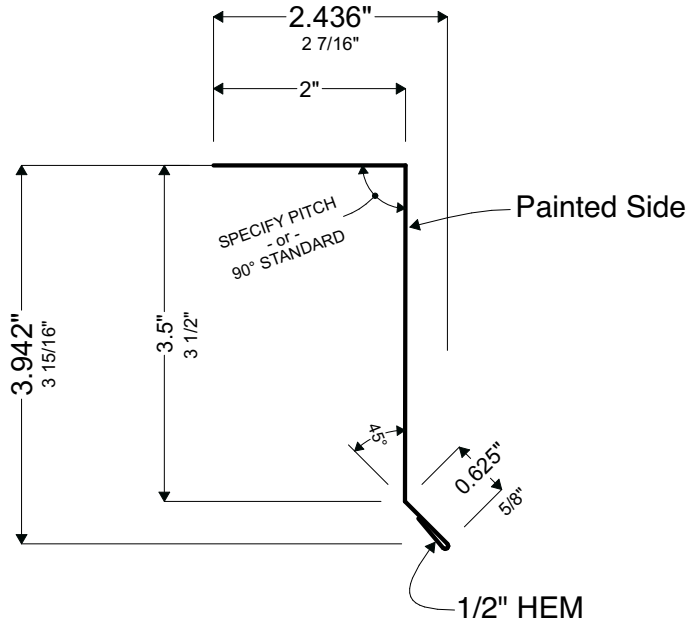
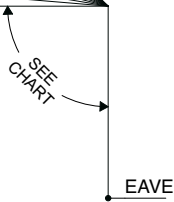

A **A1** Profile Section Detail
 Scale: 6" = 1'-0"

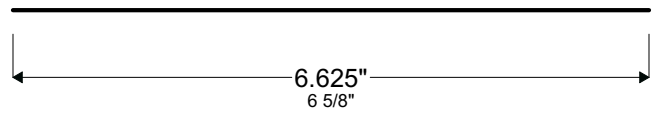

B **B1** Profile Flat Width Required
 Scale: 6" = 1'-0"

TRIM 63

PROPERTY OF IBEX
 NOT FOR REPRODUCTION WITHOUT PRIOR
 WRITTEN PERMISSION OF IBEX METAL, LLC

Product ID :	63
Name :	BEACHY BUILDING EAVE
Description :	Eave Trim (Beachy Buildings)

IBEX

IDAHO'S BEST EXTERIORS

Metal Roofing, Siding, and Trim
 P: 208-565-3002
 www.ibexmetal.com
 info@ibexmetal.com
 280 Great Northern Road
 Bonners Ferry, ID 83805

1

2

3

FRACTIONS ROUNDED TO NEAREST 1/16"
REVISED: 12/12/23

29 | 26 | 24 | 22

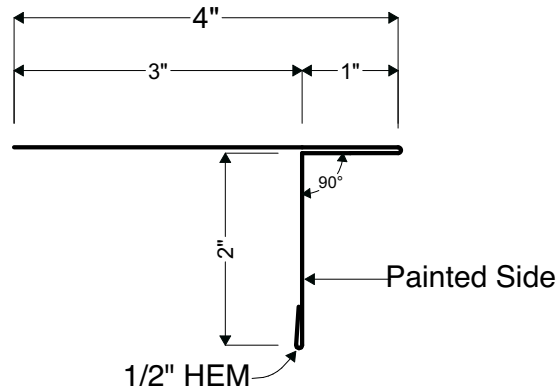

A

A1 Profile Section Detail
Scale: 6" = 1'-0"

A

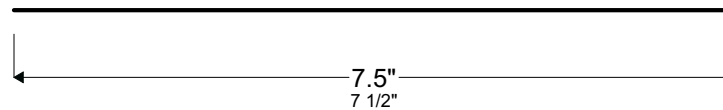

B

B1 Profile Flat Width Required
Scale: 6" = 1'-0"

B

TRIM 64 PROPERTY OF IBEX NOT FOR REPRODUCTION WITHOUT PRIOR WRITTEN CONSENT OF IBEX METAL, LLC	TRIM 64
---	----------------

<i>Product ID :</i>	64
<i>Name :</i>	ADEX ROOFING DRIP EDGE
<i>Description :</i>	D-Style Drip Edge for Concealed Fastener



Metal Roofing, Siding, and Trim
 P: 208-565-3002
 www.ibexmetal.com
 info@ibexmetal.com
 280 Great Northern Road
 Bonners Ferry, ID 83805

1

2

3

FRACTIONS ROUNDED TO NEAREST 1/16"
REVISED: 12/12/23

29 | 26 | 24 | 22

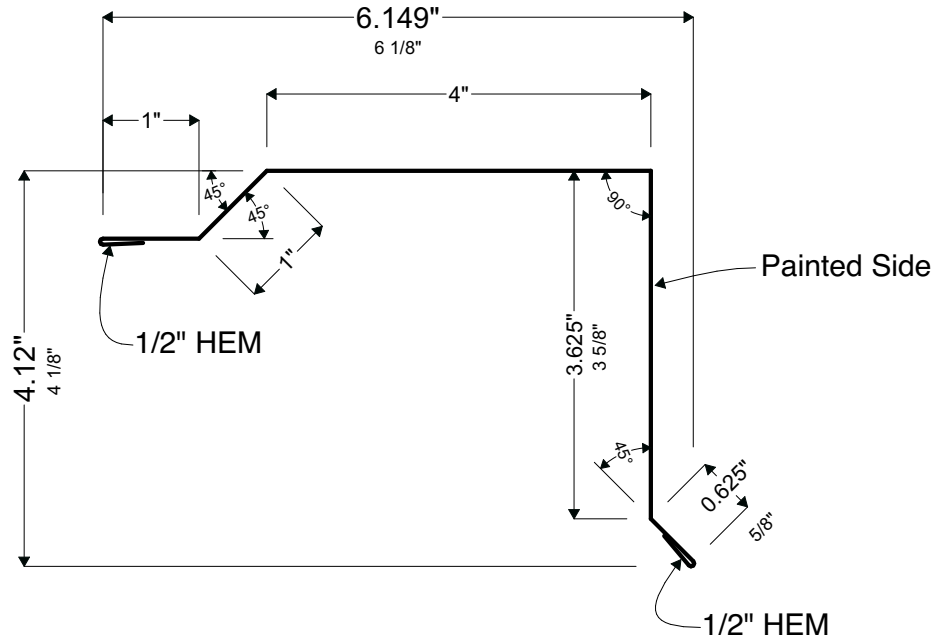

A1 Profile Section Detail
Scale: 6" = 1'-0"

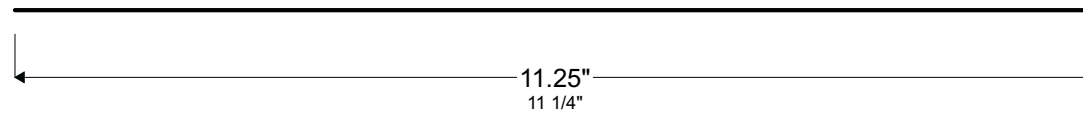

B1 Profile Flat Width Required
Scale: 6" = 1'-0"

PROPERTY OF IBEX NOT FOR REPRODUCTION WITHOUT PRIOR WRITTEN PERMISSION OF IBEX METAL, LLC TRIM 65	TRIM 65

Product ID :	65
Name :	ADEX ROOFING GABLE
Description :	Gable End Flashing (Adex Roofing)



Metal Roofing, Siding, and Trim
 P: 208-565-3002
 www.ibexmetal.com
 info@ibexmetal.com
 280 Great Northern Road
 Bonners Ferry, ID 83805

1

2

3

FRACTIONS ROUNDED TO NEAREST 1/16"
REVISED: 12/12/23

29 | 26 | 24 | 22

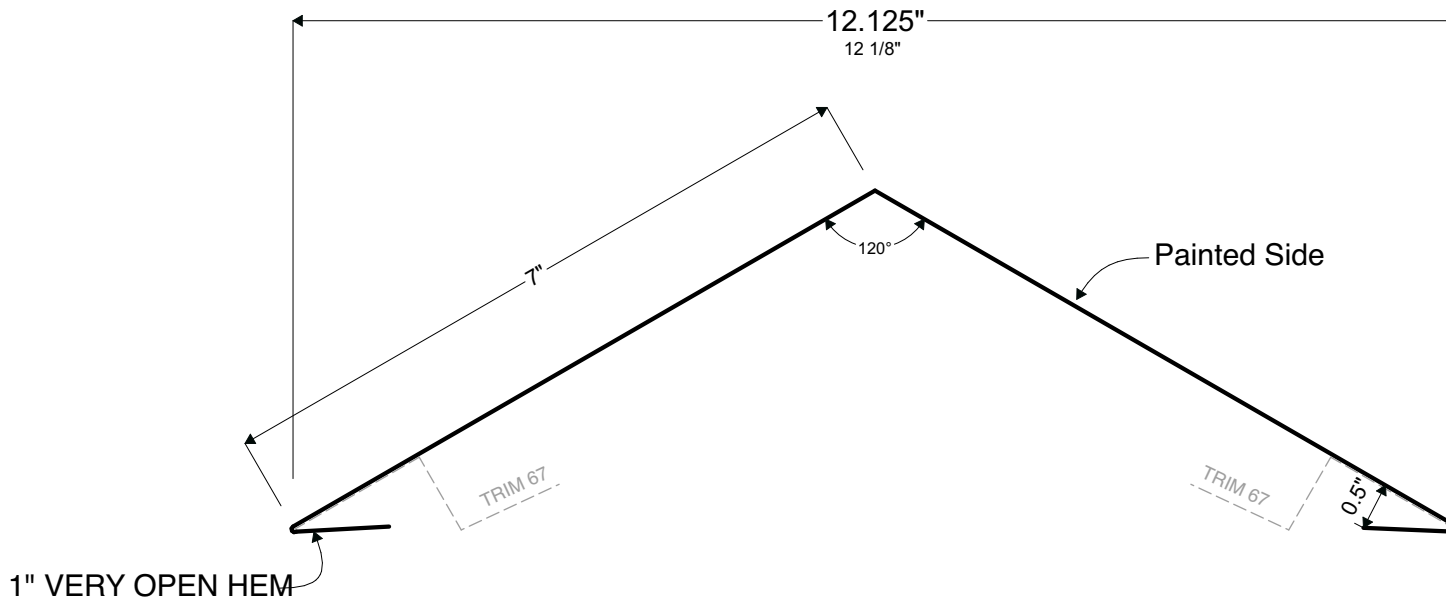

A

A1 Profile Section Detail
Scale: 6" = 1'-0"

A

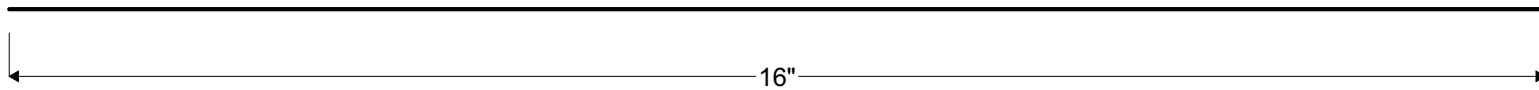

B

B1 Profile Flat Width Required
Scale: 6" = 1'-0"

B

TRIM 66 PROPERTY OF IBEX NOT FOR REPRODUCTION WITHOUT PRIOR WRITTEN CONSENT OF IBEX METAL, LLC	TRIM 66

Product ID :	66
Name :	ADEX ROOFING RIDGE
Description :	Concealed Fastener Ridge (Adex Roofing)



Metal Roofing, Siding, and Trim
 P: 208-565-3002
 www.ibexmetal.com
 info@ibexmetal.com
 280 Great Northern Road
 Bonners Ferry, ID 83805

1

2

3

FRACTIONS ROUNDED TO NEAREST 1/16"
REVISED: 12/12/23

29 | 26 | 24 | 22

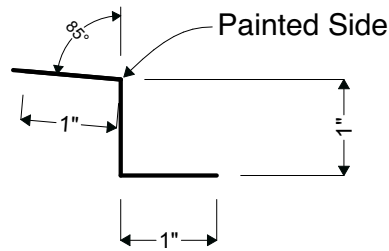

A **A1** Profile Section Detail
Scale: 6" = 1'-0"

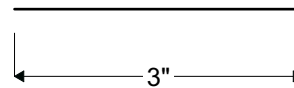

B **B1** Profile Flat Width Required
Scale: 6" = 1'-0"

PROPERTY OF IBEX
NOT FOR REPRODUCTION WITHOUT PRIOR
WRITTEN CONSENT OF IBEX METAL, LLC

TRIM 67

<i>Product ID :</i>	67
<i>Name :</i>	ADEX Z TRIM
<i>Description :</i>	Z Trim (Adex Roofing)



Metal Roofing, Siding, and Trim
 P: 208-565-3002
 www.ibexmetal.com
 info@ibexmetal.com
 280 Great Northern Road
 Bonners Ferry, ID 83805

1

2

3

FRACTIONS ROUNDED TO NEAREST 1/16"
REVISED: 12/12/23

29 | 26 | 24 | 22

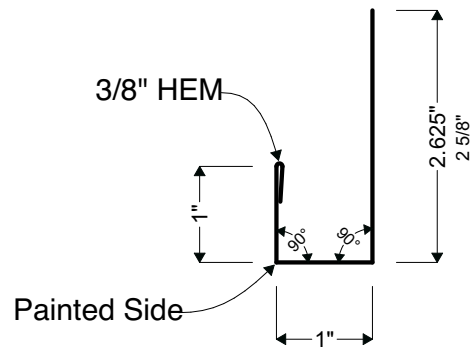

A1 Profile Section Detail
Scale: 6" = 1'-0"

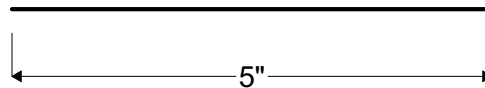

B1 Profile Flat Width Required
Scale: 6" = 1'-0"

TRIM 79

PROPERTY OF IBEX
NOT FOR REPRODUCTION WITHOUT PRIOR
WRITTEN CONSENT OF IBEX METAL, LLC

<i>Product ID :</i>	79
<i>Name :</i>	INTEGRITY POLE BUILDING J CHANNEL
<i>Description :</i>	J-Channel: Integrity Pole Building



Metal Roofing, Siding, and Trim
 P: 208-565-3002
 www.ibexmetal.com
 info@ibexmetal.com
 280 Great Northern Road
 Bonners Ferry, ID 83805

1

2

3

FRACTIONS ROUNDED TO NEAREST 1/16"
REVISED: 7/18/23

29 | 26 | 24 | 22

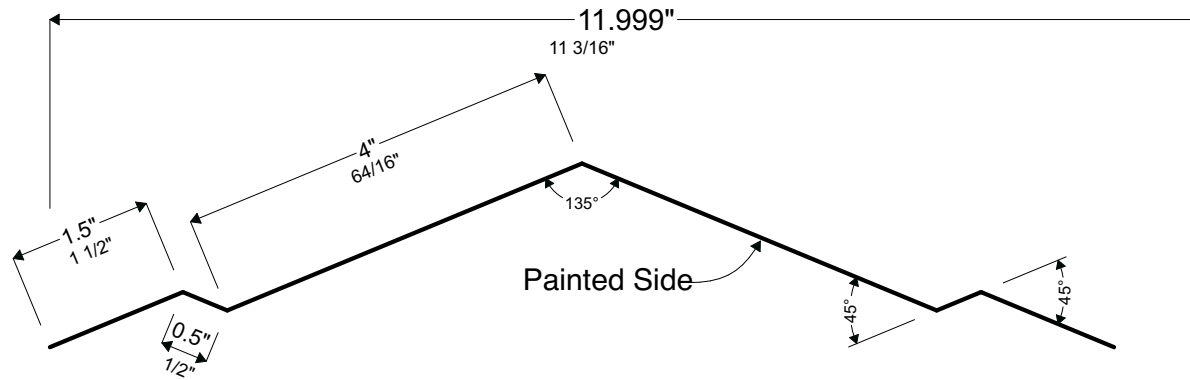

A **A1** Profile Section Detail
Scale: 6" = 1'-0"

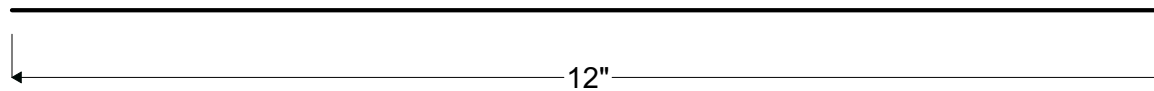

B **B1** Profile Flat Width Required
Scale: 6" = 1'-0"

TRIM 81

PROPERTY OF IBEX
NOT FOR REPRODUCTION WITHOUT PRIOR
WRITTEN CONSENT OF IBEX METAL, LLC

TRIM 81

Product ID :	81
Name :	SOFFIT RIDGE
Description :	Used Where Soffit Meets at Peak



Metal Roofing, Siding, and Trim
 P: 208-565-3002
 www.ibexmetal.com
 info@ibexmetal.com
 280 Great Northern Road
 Bonners Ferry, ID 83805

FRACTIONS ROUNDED TO NEAREST 1/16"
 REVISED: 12/12/23

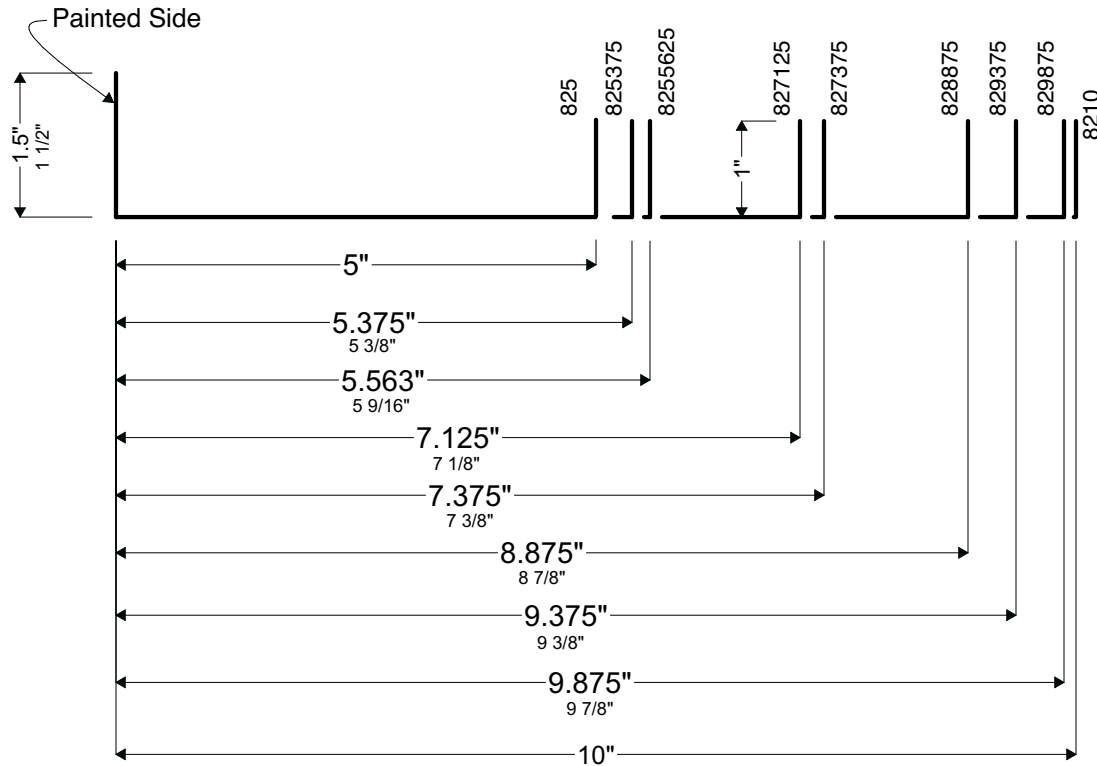

29 | 26 | 24 | 22

A1 Profile Section Detail
 Scale: 6" = 1'-0"

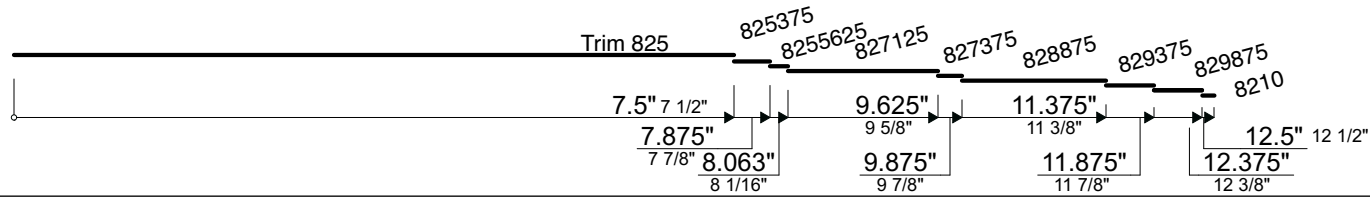

B1 Profile Flat Width Required
 Scale: 6" = 1'-0"

TRIM 82 PROPERTY OF IBEX NOT FOR REPRODUCTION WITHOUT PRIOR WRITTEN PERMISSION OF IBEX METAL, LLC	TRIM 82
--	----------------

Product ID :	825 - 8210
Name :	DOOR JAMB
Description :	Trim Covering Door Jambs (NO HEMS)



Metal Roofing, Siding, and Trim
 P: 208-565-3002
 www.ibexmetal.com
 info@ibexmetal.com
 280 Great Northern Road
 Bonners Ferry, ID 83805